

1

Introduction to Electrical Systems Design

INTRODUCTION

Chapter 1 provides an overview of electrical power distribution systems commonly encountered in residential, commercial, and industrial buildings. It discusses the representation of electrical power systems through the use of one-line and riser diagrams and introduces the history and use of the *National Electrical Code*[®] to give the reader an insight into this important document.¹ The chapter describes common system voltages used in electrical power distribution systems and the connection of electrical loads and grounding. In addition, the chapter introduces the design team, consisting of architects, civil/structural engineers, mechanical engineers, and electrical engineers, to give the reader an appreciation of the interaction that must occur among these disciplines if a design project is to be successful.

OBJECTIVES

At the end of this chapter, you will:

- Understand the overall function of the electrical power distribution system in a building
- Understand the basic philosophy behind the development of power distribution systems
- Have knowledge of the more common system voltages used for power distribution
- Have an appreciation of the *National Electrical Code*
- Appreciate the need for interaction and communication among the various professional disciplines involved in a design project

1-1

OVERVIEW OF POWER DISTRIBUTION SYSTEMS

Before attempting to design the electrical power distribution system for a building, you must understand the basic elements that make up the overall power distribution system. The overall layout of the major components of a power distribution system is often the first

¹*National Electric Code*[®] and *NEC*[®] are registered trademarks of the National Fire Protection Association, Inc., Quincy, MA 02269.

step in the design process. It is at this beginning stage that the designer develops a general idea as to the nature of the distribution system. For example, in this early stage the designer will probably establish the location of the service entrance, inquire as to the service voltage(s) available from the local utility company, determine the location of electrical closets and vaults, determine approximate locations for distribution panelboards and switchboards, and so forth. With experience comes the ability to determine more accurately these design parameters in the early stages of a project. Please be aware that these elements are only a first approximation in the overall design process. Designing any system or component is an iterative process, one that will need to be repeated several times before the design is finished.

1-2

RISER DIAGRAMS

The interconnection among the main components that comprise a power distribution system are easily shown on what is referred to as a *power riser diagram*. The actual riser diagram for a particular building will have its own unique characteristics depending on the type of occupancy—residential, commercial, institutional, or industrial. The riser diagram for any occupancy will typically show only the major electrical equipment, such as utility transformer, metering, service entrance, subpanels, large motors, HVAC equipment, emergency generator system, elevator equipment, and so on. The individual branch circuits, general-purpose convenience receptacles, and lighting are generally not shown on the riser diagram to keep it from becoming too cluttered. Keep in mind that the purpose of the riser diagram is to show the general location of the major electrical equipment and the main feeders connecting this equipment.

Residential Riser Diagram

In order to develop an understanding of the components that comprise a power distribution system, consider the riser diagram shown in Figure 1-1, which is representative of a diagram for a simple residential occupancy. The service entrance cable runs from the point of connection with the local utility company to the meter socket. The power meter used in most residential applications is referred to as self-contained, which means that the current element of the meter is rated to carry the full load current of the load to be served. Generally, services rated below 400 amps will use self-contained power meters.

The service entrance cable then proceeds from the meter socket to the main service entrance panelboard. The main service panelboard will typically have a main service disconnect, which is used to deenergize the entire electrical system in the residence. In some applications, the main service disconnect will be located in a separate enclosure between the point of entrance of the service cable into the building and the main service panel. As discussed in a later chapter, the main service disconnect may consist of up to six separate disconnects grouped together.

Note that there is a feeder from the main service panelboard to a subpanel. This subpanel may be necessary to supply a group of loads that are remote from the main service panelboard. An example would be a subpanel installed in a garage or workshop area. All

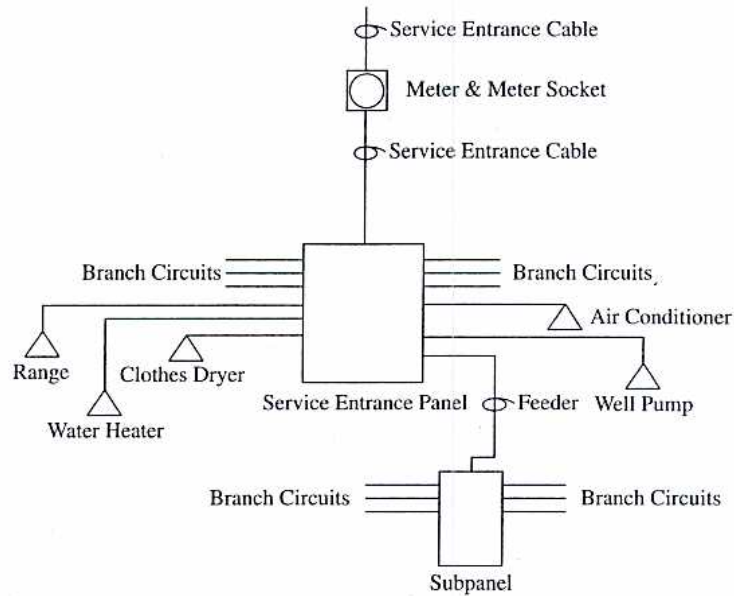

FIGURE 1-1
Riser Diagram of Residential System

loads in these areas could be supplied from the subpanel if necessary. It may also be necessary to use a subpanel if the main panel does not have sufficient space to accommodate the number of branch circuits required to supply the entire building.

Branch circuits may originate from the main or subpanel to supply the final utilization equipment. Typically, these branch circuits are rated at either 15 or 20 amps and may supply lighting and receptacle loads. Branch circuits for general lighting and appliance branch circuits are usually not shown individually on a riser diagram in order to keep the diagram from becoming too cluttered. Note also that there are several other feeders or branch circuits that supply major equipment such as the well pump, water heater, clothes dryer, range, and air conditioner.

Commercial Riser Diagram

The riser diagram shown in Figure 1-2 is for a simple commercial office building. In Figure 1-2, note that the service entrance location is shown in the lower left-hand corner of the drawing. In most instances, the electric utility company providing the service owns and maintains the main service transformer. However, in some instances this transformer may be owned and maintained by the owner of the building. The service entrance conductors originate at the transformer and pass underground through a set of conduits into a current transformer or CT cabinet. The CT cabinet contains the metering class current transformers necessary to step the load current down to a level that can be carried by the current elements of the meter. Since the equipment inside the CT cabinet is considered to be part of

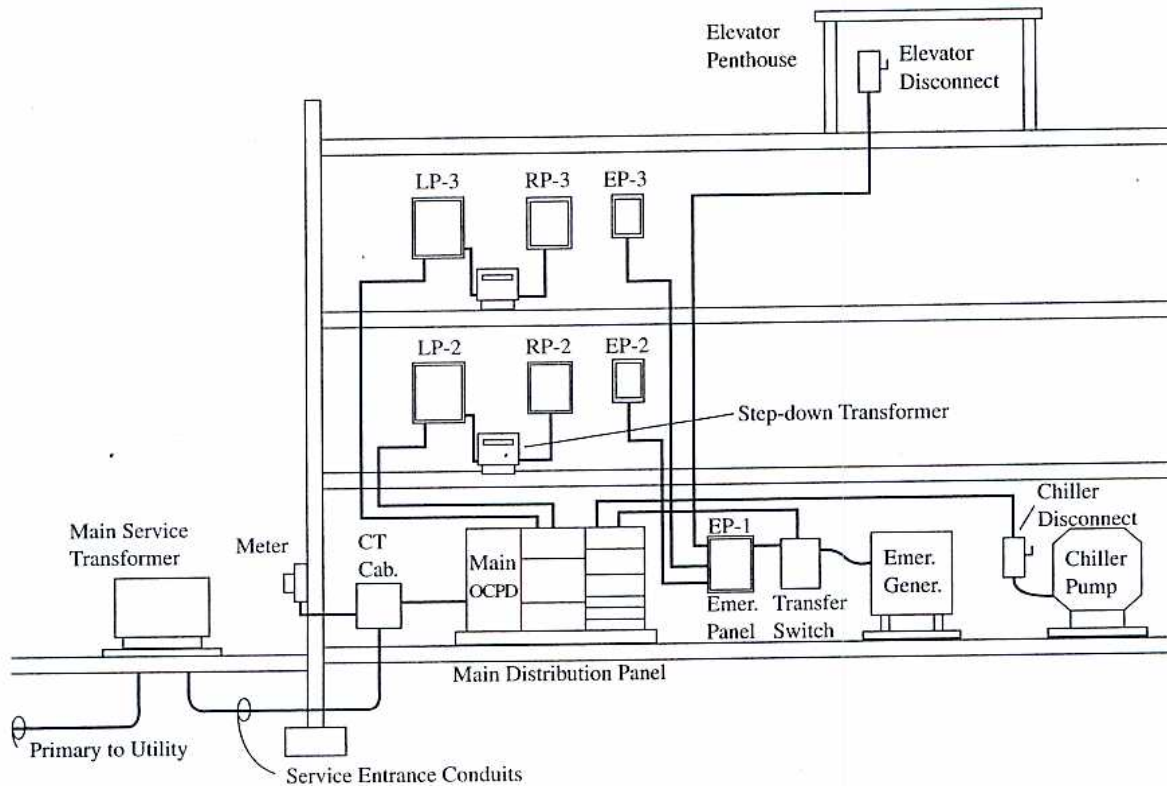

FIGURE 1-2
Riser Diagram of Commercial System

the metering equipment, the CT cabinet will also have a meter seal attached to prevent unauthorized tampering with the metering equipment. Conductors carrying the secondary current from the current transformers and conductors supplying the voltage potential to the meter are contained in a separate conduit between the CT cabinet and the meter socket. In some applications, the CTs are mounted on the secondary bushings of the pad-mount utility supply transformer, thereby eliminating the need for a CT cabinet. Keep in mind that all metering and supply issues must be coordinated with the local utility company.

From the CT cabinet, the service entrance conductors continue on to the main service equipment. As in the case of the residential building, the main service equipment will have a main disconnect switch or switches. This main service equipment may also have other feeder overcurrent devices, such as fuses or circuit breakers, installed. In this particular example, the service is 480 V, three phase, although other service voltages may be available for commercial occupancies.

Note in Figure 1-2 that there are several 480 V feeders originating from the main service equipment to other electrical equipment, such as the chiller pump, which is part of the HVAC equipment of this building. Note also that there are several 480 V feeders from

the main service equipment to lighting subpanels, designated LP-1, LP-2, etc., located on each floor of the building. It is common in commercial buildings supplied by 480 V, three-phase service, to use 277 V lighting circuits. From each of these lighting subpanels, a feeder is used to connect to the primary of a step-down transformer, which transforms the voltage from 480 V to 208Y/120 V. The low-voltage side of the transformer is connected to a receptacle panelboard, designated RP-1, RP-2, etc., and are used to supply 120 V branch circuits for receptacle loads and other loads requiring 120 V supply.

In some instances, it is necessary to provide for emergency power. In this facility, the emergency power requirements are met by the emergency generator, transfer switch, and emergency panel. The emergency panel has two sources of supply: the emergency generator and the feeder from the main service equipment. The transfer switch provides the means of switching from the normal supply (main service) to the emergency supply. In the event of loss of voltage on the utility system, the transfer switch logic will signal the emergency generator to start. After the generator starts and comes up to rated speed, the transfer switch will switch the emergency panelboard over to the generator supply. When utility power is restored, there will be a time delay before the transfer switch switches back over to the normal utility supply. This time delay is necessary to ensure that the utility service has been restored on a permanent, not momentary, basis. The emergency generator will then go into a cool-down mode before shutting down.

Note that there are several emergency circuits originating from the emergency panel board in the lower level to emergency panelboards on each floor of the building. Emergency lighting and receptacle circuits may be connected to these emergency panelboards as required. Also, note that there is a feeder for the elevator equipment that is supplied from the emergency panelboard. This is to ensure continuous operation of the elevator equipment in the event of a power failure on the utility supply.

One-Line Diagram of Commercial Building

As discussed in the previous section, the power riser diagram will show the layout of the electrical system of a building with some detail as to the actual physical location of the electrical equipment. This level of detail is often not needed, particularly when performing short-circuit studies, coordination studies, voltage-drop studies, or other system studies. A shorthand version of the power riser diagram is the one-line diagram. The one-line diagram shows only the electrical connection of the electrical system components, the ratings and types of overcurrent protection devices, the type and sometimes length of cables for major feeders, etc. The individual branch circuits are generally not shown. A representative one-line diagram for the commercial building whose power riser diagram was shown in Figure 1-2 is shown in Figure 1-3.

Notice in Figure 1-3 that the electrical connection of the components follows the physical layout of the components, a correlation that can be observed by comparing Figures 1-2 and 1-3. The main service transformer is shown, along with its respective voltage and apparent power ratings: 12,470-480Y/277 V, 750 kVA. Note that this information may or may not be found on the riser diagram. The CT cabinet and metering are also shown on the one-line diagram. In this instance, the cable type, size, and length are not

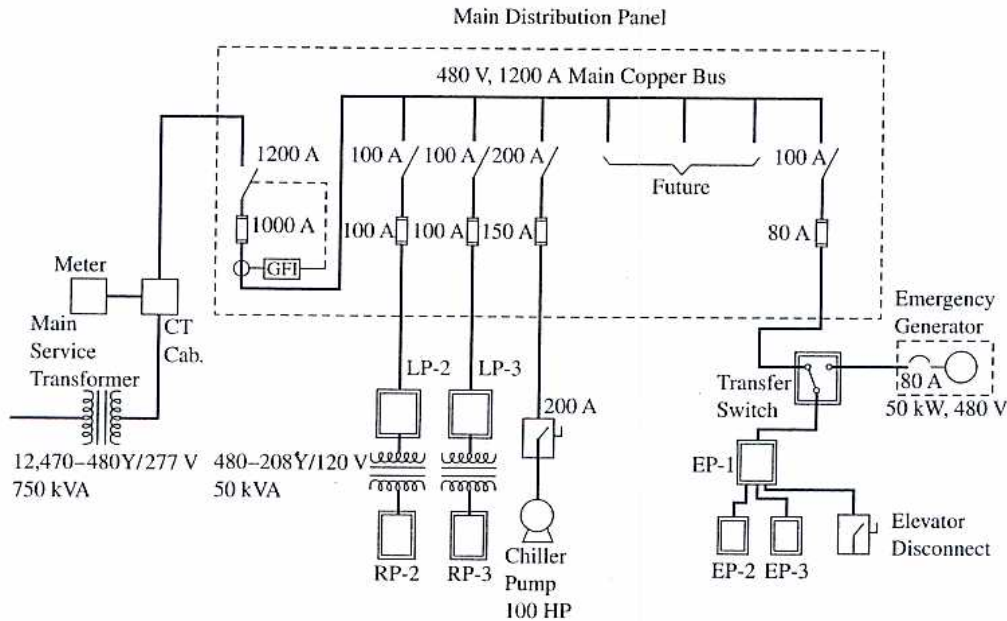

FIGURE 1-3
One-Line Diagram for Commercial System

shown for purposes of clarity. However, on most one-lines this cable information would be shown. When the cable sizes, types, and lengths are not shown on the one-line diagram, they would typically be shown on a cable and conduit schedule.

Figure 1-3 shows the main distribution panel with the rating of the main bus indicated: 480 V, 1200 amp main copper bus. The main 1200 amp disconnect switch is also shown, along with the 1000 amp fuse and ground fault protection, or GFI. All of the 480 V feeders originating from the main distribution panel and their respective disconnect rating and fuse ratings are shown. Note that the feeders supplying the lighting panels LP-2 and LP-3 are included, but that the individual lighting branch circuits originating from these panel boards are not. The step-down transformers, and, typically, their ratings, between the two lighting panels and receptacle panels RP-2 and RP-3 are also shown. Also, like the lighting branch circuits, the receptacle branch circuits are not shown on the one-line diagram. Instead, the branch circuits for lighting, receptacles, and other loads will be shown on the cabling diagram of the building floor plans. The location of the branch circuit breakers will typically be shown on the panel schedules for the building.

The 480 V feeder from the main distribution panel to the transfer switch is shown along with its rating: 100 A disconnect, 80 A fuse. Shown in the transfer switch is the internal switch mechanism for normal feed to the emergency panel EP-1. Panel EP-1 is clearly shown feeding emergency panels EP-2 and EP-3 on the second and third floors, respectively. Also, the feeder supplying the elevator disconnect is shown as are the ratings of the emergency generator and the generator breaker. Note that the generator, emergency

circuits, and emergency panelboards are all 480 V. As such, the circuits originating from these panelboards will be either 277 V, suitable for lighting, or 480 V, suitable for critical three-phase 480 V loads only. If it is desired to supply receptacle or lighting loads at 120 V, additional step-down transformers would have to be installed and fed from the emergency panels EP-1, EP-2, or EP-3. The secondaries of these additional step-down transformers would feed emergency panelboards suitable for supplying branch circuits at 120 V.

Some of the more common electrical plan and one-line diagram symbols are shown in Figure 1-4. These symbols are a representative sampling of the hundreds of symbols encountered in electrical system design.

	15 A, 125 V, duplex receptacle
	20 A, 125 V, duplex receptacle
	15 A, 125 V, single receptacle
	20 A, 125 V, single receptacle
	single-pole single-throw switch
	single-pole, double-throw switch (three-way)
	double-pole, double-throw switch (four-way)
	special-purpose receptacle
	disconnect switch (plan drawing)
	ground-fault-protected receptacle
	weatherproof receptacle
	isolated ground receptacle
	electric motor
	resistance load
	key-operated switch
	switch with pilot light
	generator
	circuit breaker
	fuse
	power transformer
	disconnect switch (one-line diagram)
	two-conductor cable
	two-conductor cable with ground
	three-conductor cable
	three-conductor cable with ground
	conduit turned up
	conduit turned down

FIGURE 1-4
Common Electrical Plan Symbols

1-3 SYSTEM VOLTAGES

An understanding of the various system voltages used in electrical systems is of great importance in their design and maintenance. Knowing how the loads are connected between phases and between phase and neutral will enable the designer to properly design and specify the components of an electrical system and enable maintenance personnel to safely maintain and operate these systems.

There are several different system voltages that may be available for the power supply, and these must be determined from the utility supplying the electric service. Keep in mind that not all service voltages are available for any load. For example, three-phase service may not be available for residential buildings, minimum load requirements may be specified for supplying three-phase service, minimum service voltage may be specified for large loads, and so on. The designer is responsible for determining the service voltage requirements. Figure 1-5 is a schematic representation of some of the more common service voltages.

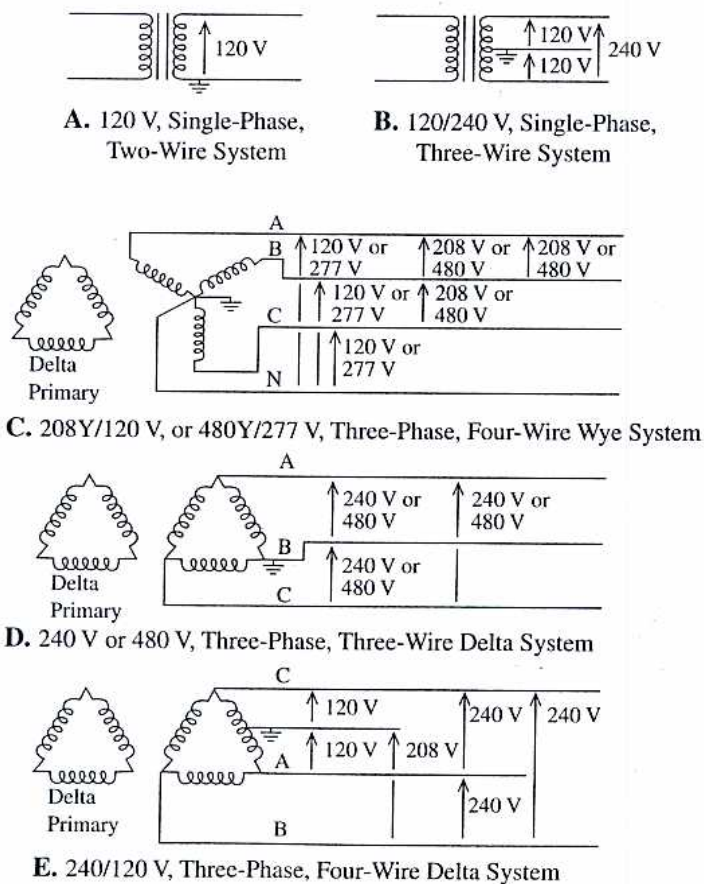

FIGURE 1-5
Common Service Voltages

120 V, Single-Phase, Two-Wire System

The schematic diagram for the 120 V, single-phase, two-wire system is shown in Figure 1-5(A). One of the supply conductors is referred to as the *ungrounded conductor* or *hot conductor* and is fully insulated. The other supply conductor is grounded at the transformer secondary and is referred to as the *neutral* or *grounded conductor*. This conductor is connected to the transformer case and earth grounding system (typically, a ground rod) at the transformer location. At the service entrance location, the grounded conductor is again connected to an earth grounding system. However, on the load side of the main service disconnect, a separate equipment grounding conductor is present in addition to the grounded conductor. It is extremely important to note the distinction between the *grounding conductor* and the *grounded conductor*. The *grounding conductor* serves as the safety ground for electrical apparatus, while the *grounded conductor* provides a return path for load current back to the source. Under normal operating conditions, the *grounding conductor* carries no current and serves to maintain a zero volt potential for electrical apparatus case grounding. The only time the *grounding conductor* carries current is in the event of a short circuit between the ungrounded conductor (hot) and ground. Both the ungrounded conductor and the grounded conductor are fully insulated inside the premises. All electrical loads are connected between the ungrounded (hot) conductor and the grounded (neutral) conductor. Under no circumstances are loads permitted to be connected between the ungrounded conductor and the equipment grounding conductor.

120/240 V, Single Phase, Three Wire

The 120/240 V, single-phase, three-wire system is the most common system for single-phase loads. The three-wire system is derived by center tapping the transformer secondary, as shown in Figure 1-5(B). This center tap is connected to earth ground at the transformer location. The system-grounded conductor originates from this center tap. As in the previous system, the grounded conductor is also connected to earth ground at the service entrance. The *grounding conductor* and *grounded conductor* must be kept separate inside the building. Electrical loads are not permitted to be connected between any of the ungrounded conductors and the equipment grounding conductor.

The ungrounded supply conductors originate from the "outer" portion of the secondary transformer winding. Electrical loads requiring 120 volts are connected between either of the two ungrounded conductors and the grounded conductor. Likewise, electrical loads requiring 240 volts are connected between the ungrounded conductors. This is commonly referred to as the "220 volt" line. This system has an advantage over the 120 V, two-wire system in that large electrical loads such as ranges and hot water heaters can be designed and operated at 240 volts. Operation at this higher voltage results in less current draw for the same power rating.

208Y/120 V, Three Phase, Four Wire

The 208Y/120 V, three-phase, four-wire system is the preferred system for smaller three-phase load requirements. As shown in Figure 1-5(C), the transformer secondaries are

connected in the form of a wye. As such, this system is commonly referred to as a *four-wire wye-connected system*. The common point of the three transformers is earth grounded and establishes connection for the grounded conductor. As in the previous systems, the grounded conductor is also connected to earth ground at the service entrance. The grounding conductor and grounded conductor must be kept separate inside the building. Electrical loads are not permitted to be connected between any of the ungrounded conductors and the equipment grounding conductor.

The voltage between any of the three phases—"a," "b," or "c"—is 208 volts. These three phases are the ungrounded conductors of the system. Large three-phase loads are connected between the three ungrounded phase conductors. Likewise, smaller, 120 volt, single-phase loads such as receptacles and lighting are connected between any of the three phase conductors and the neutral conductor. In this system, it is permitted to connect 208 volt, single-phase loads between any two of the three ungrounded phase conductors.

480Y/277 V, Three Phase, Four Wire

The 480Y/277 V, three-phase, four-wire system is also represented in Figure 1-5(C); it is preferred for larger three-phase load requirements and is very similar to the 208Y/120 V, three-phase, four-wire system previously discussed. Like the 208Y/120 V system, this system is also referred to as a four-wire wye-connected system. The common point of the three transformers is earth grounded and establishes connection for the grounded conductor. As in the previous systems, the grounded conductor is also connected to earth ground at the service entrance. The grounding conductor and grounded conductor must be kept separate inside the building. Electrical loads are not permitted to be connected between any of the ungrounded conductors and the equipment grounding conductor.

The voltage between any of the three phases—"a," "b," or "c"—is 480 volts, and they are the ungrounded conductors of the system. Large three-phase loads are connected between the three ungrounded phase conductors. Likewise, smaller, 277 volt, single-phase loads such as lighting are connected between any of the three phase conductors and the neutral conductor. In this system, it is permitted to connect 480 volt single-phase loads between any two of the three ungrounded phase conductors.

240 V, Three Phase, Three Wire

The 240 V, three-phase, three-wire system is shown in Figure 1-5(D). This three-phase system has one of the phases ("b" phase) grounded at the transformer location and at the service entrance. Phase "b" is the grounded conductor of the system, while phases "a" and "c" are the ungrounded conductors. This type of system is often referred to as a *corner-grounded system*, since one of the corners of the delta is grounded. As in the previous systems, the grounded conductor and grounding conductor are kept separate inside the premises. Loads requiring 240 V three phase may be connected between phases "a," "b," and "c." It is also possible to connect 240 V single-phase loads between any two of the three phases.

240/120 V, Three Phase, Four Wire

The 240/120 V, three-phase, four-wire system is shown in Figure 1-5(E). Note that there are three transformer secondary windings shown. The center tap of one of the transformers is connected to earth ground and serves as the connection for the grounded conductor. As in the previous systems, the grounded conductor is also connected to earth ground at the service entrance. The grounding conductor and grounded conductor must be kept separate inside the building, as with the other systems. Electrical loads are not permitted to be connected between any of the ungrounded conductors and the equipment grounding conductor.

There are three ungrounded conductors in this system, forming a 240 volt, three-phase delta connection. Large 240 volt, three-phase loads such as motors and resistance heat are connected between the three ungrounded conductors—"a," "b," and "c." Smaller, 120 volt, single-phase loads are connected between either phase "a" and the grounded conductor, or phase "c" and the grounded conductor. Larger 240 volt, single-phase loads are connected between phases "a" and "c." The voltage between phase "b" and the grounded conductor is 208 volts and is considered the high leg to ground. It is not permitted to connect any 208 volt single-phase loads between phase "b" and the grounded conductor in this system. Because of some unique operating problems that may arise from this type of system, its use is not recommended.

1-4

THE NATIONAL ELECTRICAL CODE

The National Fire Protection Agency (NFPA) is the organization responsible for publishing codes applicable to life safety. Included in the NFPA publications is the *National Electrical Code*. Initially developed in 1897, and taken under sponsorship by the National Fire Protection Agency in 1911, the *NEC* is updated every three years.

The primary purpose of the code is to establish provisions for the design, installation, and maintenance of electrical systems, with due regard for public safety and the protection of property. Although the *NEC* is the fundamental reference used in the design, installation, and maintenance of electrical systems, it is not a design guide in and of itself—it does not provide a set of guideline specifications, but establishes a general set of rules governing electrical power distribution systems.

Many agencies having jurisdiction over the installation of electrical systems have adopted the *NEC* as the appropriate standard. The "local authority having jurisdiction" is how the *NEC* frequently refers to the local inspection agency. This inspection agency may choose to adopt the code in its published form or may set additional rules and regulations that exceed the requirements of the *NEC*. The designer must check with the local authority to determine if there are additional regulations.

1-5

THE DESIGN TEAM

The design of any system requires coordination and interaction among many different engineering disciplines. Usually, there will be a project manager assigned to oversee the total project design. This individual will be selected from one of the disciplines involved in

9

Grounding

INTRODUCTION

Grounding of electrical systems, services, and equipment is done primarily for reasons of safety. In the event of an electrical short circuit between an energized supply conductor and any of the metallic raceway components, the hazards of electrocution must be minimized. In addition, short circuits to ground may produce an excessive amount of arcing at the point of fault, resulting in fires with subsequent damage to property and possibly loss of life. Lightning-induced surges must also be discharged to earth ground to prevent dangerous overvoltages from occurring in various equipment and on equipment enclosures.

System grounding refers to the intentional connection of one of the supply circuit conductors to earth at a particular location. *Service grounding* refers to the connection of the supply conductors and service entrance equipment, such as meters, panels, and disconnects, to earth ground. *Equipment grounding* refers to the intentional connection of equipment enclosures and raceways as well as to earth ground. This chapter discusses the reasons for grounding electrical systems, the types of systems that are required to be grounded, methods of grounding, the grounding electrode system, and methods of equipment and raceway grounding.

OBJECTIVES

Upon completion of this chapter, you will:

- Understand the need to properly ground systems and circuits
- Understand the types of systems required to be grounded and the ways in which these systems are grounded
- Understand the requirements for grounding of service conductors
- Understand the difference between the grounded conductor and the equipment grounding conductor
- Understand the installation and bonding requirements for the grounding electrode system
- Understand service entrance grounding requirements
- Understand requirements for grounding of separately derived systems
- Understand the requirements for grounding and bonding of subpanels
- Be able to properly size equipment bonding jumpers
- Be able to properly size equipment grounding conductors

9-1 REASONS FOR GROUNDING

Minimize Overvoltages

As previously stated, grounding is done primarily for reasons of safety. Figure 9-1 illustrates the need for grounding to prevent overvoltages from occurring on the power system. Note that a lightning arrester is located on the top of the pole-mounted transformer, next to the transformer bushing. The utility phase conductor is connected to the arrester, as shown in the schematic. The other side of the arrester is connected to ground, as shown. For normal power system voltages and operation, the lightning arrester assumes an open circuit condition. If the voltage across the arrester exceeds the voltage rating of the arrester, it

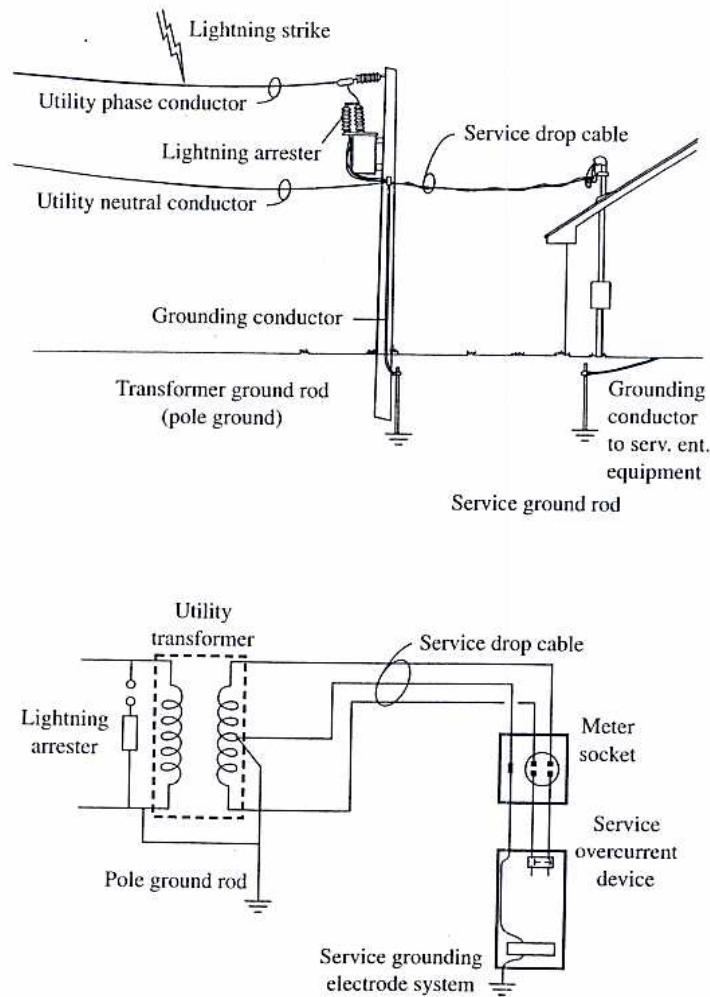

FIGURE 9-1
Reasons for Grounding

goes into operation, resulting in a low-impedance path to ground through the arrester. The utility neutral conductor is also connected to the earth ground, as shown.

On the low-voltage side of the transformer, one of the secondary terminals is connected to earth ground. The grounded service conductor is routed, along with the ungrounded service conductors, to the meter socket, then to the service entrance panel of the building. Note that the grounded service conductor is also connected to earth ground at the service entrance through the grounding electrode system.

In reference to Figure 9-1, assume a lightning strike occurs on the utility phase conductor. This lightning strike will induce a surge voltage in the phase conductor as the surge current travels along the phase conductor toward earth ground. A surge voltage will also be induced in the utility neutral conductor due to electromagnetic induction. When the lightning-induced surge voltage reaches the pole-top transformer, the large magnitude of the surge voltage causes the lightning arrester to operate. Operation of the lightning arrester allows the surge to discharge to ground, traveling down the grounding conductor alongside the pole, and then to the ground rod located next to the pole. Essentially, a closed path to ground for the flow of surge current electrons has been established. Once the flow of electrons ceases, the lightning arrester once again assumes an open circuit condition to the normal system voltage.

In addition to providing a path to ground for the flow of electrons, the connection of one of the service supply conductors to earth ground stabilizes service voltage. Without the earth ground, the service voltage may float and could become dangerously high under certain conditions. Likewise, the connection of the utility neutral to earth ground ensures that the voltage on the utility system neutral with respect to the surrounding earth remains at an acceptable level.

Limit Voltage Potential on Equipment Enclosures

Grounding as a means of limiting the voltage potential on equipment enclosures is illustrated in Figure 9-2. Note that conditions are shown for both an ungrounded motor frame and a grounded motor frame. The ungrounded motor will operate satisfactorily with no obvious indication that the motor frame is not grounded. But consider what happens if an insulation failure occurs in one of the motor leads or the windings themselves, resulting in one of the phase (ungrounded) conductors coming in contact with the motor frame. Since the motor frame is not grounded, there is no path for the flow of current to return to the system, with the result that there is no increase in current through the motor feeder overcurrent devices and the system remains energized. However, the connection of the energized conductor to the motor frame now places a voltage equal to the line-to-ground voltage of the system onto the motor frame. On a 480 V, three-phase system, the result is a voltage of 277 V applied to the motor frame. If someone were to place one hand on the motor frame and the other hand on a grounded surface, such as the building structural steel, the path of current flow would be directly through the heart, resulting in electrocution.

Connecting the motor frame to ground by use of an equipment grounding conductor provides a low-impedance path between the motor frame and ground. Since the equipment grounding conductor is connected to the grounding electrode system at the supply, the motor frame is essentially tied to ground potential. If an ungrounded phase conductor were