



VARIAN

CP-3800 GC

Getting Started Manual

*Getting Started ♦ Installation ♦ Basic Operation
Maintenance ♦ Parts and Supplies*



Varian, Inc.
2700 Mitchell Drive
Walnut Creek, CA 94598-1675/usa

Read Before Operating

Important Safeguards



The following items are frequently not recognized or are overlooked by new users while learning to operate a Gas Chromatograph. They are brought to your attention to safeguard against damage to your equipment.

- Carrier gas must be flowing through the column before heating the column oven. Carefully evaluate columns that have been heated with no carrier gas flowing through and discard, if damaged. Ensure the injector contains a septum and there is a positive flow of carrier gas before heating the column.
- Become familiar with the location and identity of injector and detector options prior to making settings at the GC keyboard and pneumatics panel. For example, determine the physical location of the injector you want to use (front, middle, or rear) and identify the specific pneumatic controls associated with it (manual pneumatics or Electronic Flow Control). Similarly, determine the physical location of the detector you want to use and identify the specific pneumatic controls for this detector.
- Heating an ECD to elevated temperatures without carrier or make-up gas flowing through it can damage the ECD cell. This can happen inadvertently especially when the ECD is not in use. For this reason, it is recommended that a low flow of carrier or make-up gas be maintained through an ECD at all times.
- If your system has a TCD, gas must be flowing through both channels to protect the filaments. Turn power to filaments off when not in use.

Important Tips Regarding 3800 Operation

- After editing the active method, it must be re-activated before running the next analysis. Always remember to activate a method after you have made edits, if you intend to run that method next.
- Note that the GC control keys allow access to both the active method status (top of the display) and the current method available to edit (middle of the display). If you want to edit the active method then you must make it the current edit method. Both the current active method and edit method are listed on the top line of the 3800 display.
- If a potentially hazardous fault is detected, such as a thermal runaway, the 3800 shuts down the affected component and reports the fault. After correcting the fault, normal operation is restored by powering the 3800 OFF then ON.

Table of Contents

INTRODUCTION	5
Guide to the 3800 User Manuals.....	5
Finding Information in these Manuals.....	5
Abbreviations	5
Brief Description of the 3800 Gas Chromatograph	6
Configuration and Options.....	7
INSTALLATION	9
Site Requirements for GC Installation	9
Power Requirements	9
Space Requirements	10
Environmental Requirements.....	10
Peripheral Connectors	11
GC Installation	12
Inspection.....	12
Unpacking.....	12
Remove Protective Devices.....	12
Connect Data Handling Peripherals	12
Select Gases.....	13
Install Gas Regulators and Set Pressures.....	13
Connect Gases	13
Connect GC to Power	14
Turn Power On.....	14
Factory Default States and Settings	14
Quick Guide to the 3800 Keyboard and Display	15
Getting Around the Keyboard	15
Column Installation and Conditioning.....	28
Connect Column to	28
Nuts and Ferrules for Capillary Columns.....	29
Connect Capillary Column to Injector	30
Nuts and Ferrules for Packed Columns.....	31
Connect a Packed Column to the Injector	31
Varian Test Column	32
Identify Carrier Gas Controls and Turn on Flow	32
Split Vent Flow and Septum Purge Flow	32
Set Carrier Gas Flow Rate to Condition Column.....	34
Note for Capillary Column Users	34
Conditioning the Injector and Column.....	34
Connect Capillary Column to Detector	35
Column Insertion Depths for Varian Detectors	36
Connect Metal Packed Column to Detector.....	37
Check for Leaks	37

BASIC OPERATION.....	39
Setting Carrier and Detector Gas Flow Rates	39
Condition the GC System.....	41
Build a Method to Analyze a Test Sample	41
Method to Analyze a Varian Test Sample on a Varian Test Column	42
Prepare the Test Sample	43
Solvents for GC	44
Sample Volume and Injection Rate.....	45
Inject the Test Sample	45
MAINTENANCE.....	47
Overview	47
General GC Maintenance	48
Check and Renew Gas Supplies.....	48
Leak Check.....	48
Gas Purifier Replacement	50
Injector Maintenance	52
CP-1177 Injector	53
Remove the Glass Insert.....	55
Replace the Glass Insert	55
Clean the Glass Insert	56
Deactivate the Glass Insert	57
1079 Injector.....	59
Remove the Glass Insert.....	61
Replace the Glass Insert	62
Clean the Glass Insert	63
Deactivate the Glass Insert	64
1041 Injector.....	66
Hardware Replacement and Cleaning Procedures.....	66
Septum Replacement.....	66
Needle/ Syringe Cleaning.....	67
Leak Checking.....	68
1061 Injector.....	70
Replacing the 1061 Glass Insert	70
Remove the Glass Insert.....	71
Replace the Glass Insert	72
Clean the Glass Insert	72
Flame Ionization Detector	74
Clean the Flame Tip and Internal Parts.....	74
Replace the Ferrule	75
Thermionic Specific Detector	76
Cleaning/ Maintenance.....	76
Bead Cleaning.....	76
Flame Tip and Internal Parts Cleaning.....	76

Ferrule Replacement	76
Electron Capture Detector	78
Thermal Cleaning With Carrier Gas.....	78
Thermal Conductivity Detector	79
Pulsed Flame Photometric Detector.....	79
PARTS AND SUPPLIES.....	81
To Order Parts and Supplies	81
Injectors	81
CP-1177 Injector	81
1079 Injector	82
1041/1061 Injector	82
Detectors	83
Flame Ionization Detector	83
Thermionic Specific Detector.....	83
Electron Capture Detector	83
Thermal Conductivity Detector.....	83
Pulsed Flame Photometric Detector	83
Figure 1 Connectors for Peripheral Equipment.....	11
Figure 2 3800 GC Keyboard.....	15
Figure 3 CP-1177 Injector - Cross-Sectional View.....	54
Figure 4 1079 Injector - Cross-Sectional View	60
Figure 5 1041 Injector Assembly	67
Figure 6 1061 Injector Assembly	70
Figure 7 Flame Ionization Detector Assembly.....	75
Figure 8 Thermionic Specific Detector Assembly	77
Table 1 Physical Dimensions of the 3800 GC System Components	10
Table 2 Flow Rates for Carrier and Detector Gases for the 3800 Gas Chromatograph.....	39

The CP-3800 GC is a versatile and easy to use analytical instrument. If you have not had much experience with Gas Chromatography equipment, we recommend that you read both the Getting Started and Operator's manuals completely before using your instrument. If you are an experienced chromatographer, the following sections are recommended to get up and running quickly.

When your CP-3800 arrives from the Varian factory, it will have already been configured and tested. To begin using your instrument, follow the steps below:

1. Unpack the instrument (Consult page 12)
2. Connect your GC to the appropriate gas supplies (Consult page 13)
3. Connect power to your GC (Consult page 14)
4. Install a column (Consult "Column Installation and Conditioning", page 28)
5. Configure the column in Setup (Consult "Setup", page 17)
6. Build a Method (Consult "Build a Method ...", page 41)
7. Inject a Sample (Consult "Inject a test Sample", page 45)

Introduction

Guide to the 3800 User Manuals

The purpose of these User Manuals is to provide instructions for the safe installation and operation of the Varian 3800 Gas Chromatograph.

Finding Information in these Manuals

The 3800 is supplied with two user manuals: a Getting Started Manual and an Operator's Manual. The Getting Started Manual contains basic installation, operation and maintenance information intended to familiarize the new user with the 3800. The Operator's Manual contains more detailed information, including information on the specific installed options on the 3800.

Abbreviations

The following abbreviations appear in this Manual:

ac	alternating current
dc	direct current
ECD	Electron Capture Detector
EFC	Electronic Flow Control
FID	Flame Ionization Detector
GC	Gas Chromatograph
GC/MS	Gas Chromatograph/Mass Spectrometer
ID	Inner Diameter
OD	Outer Diameter
P/N	Part Number
PFPD	Pulsed Flame Photometric Detector
TCD	Thermal Conductivity Detector
TSD	Thermionic Specific Detector

Brief Description of the 3800 Gas Chromatograph

The following are some of the key features of the 3800:

- Three injectors, columns and detectors can be installed and operated simultaneously.
- The CP-1177 Split/Splitless capillary injector is optimized for both split and splitless injections.
- The 1079 Universal Capillary Injector provides five modes of injection - isothermal split and splitless, temperature ramped splitless, on-column and large volume. It is equipped with either LN₂ or CO₂ coolant.
- Electronic or manual control of carrier gas.
- Ethernet® communications with full networking capability.
- A full suite of universal and selective detectors - FID, TCD, ECD, TSD (N, P), PFPD (S, P, N, C, Metals), and Mass Spectrometers.
- Large, swing-out pneumatics for easy access.
- Seven heated zones and seven external events for maximum flexibility and custom configurations.
- Up to eight separately programmed and stored analytical methods.
- Intuitive, function-based keyboard with large, dot matrix display for ease of use in method building and viewing instrument status.
- Built-in Custom Solutions capability - valved systems, custom plumbing, six-position valve oven, methanizer.
- Large column oven for easy access and installation of up to three analytical columns.
- A complete range of GC automation and sample preparation techniques— the CP-8400 AutoSampler with dual and duplicate injections into two injectors, Solid Phase MicroExtraction, Purge and Trap, Heated Headspace, and the Archon Purge and Trap AutoSampler

Configuration and Options

The 3800 has seven heated zones, one of which is always configured as the column oven. The following options may be configured in the other six available heated zones:

- CP-1177 Split/Splitless Capillary Injector
- 1079 Universal Capillary Injector
- 1041 On-Column Injector for large bore (0.53 mm ID) or packed columns
- 1061 Flash Vaporization Injector for large bore or packed columns
- Small Valve Oven
- Large Valve Oven
- Flame Ionization Detector
- Thermal Conductivity Detector
- Electron Capture Detector
- Thermionic Specific Detector
- Pulsed Flame Photometric Detector
- Methanizer
- SPT

Any combination of three injectors may be installed on the 3800. If a valve oven is installed, it normally replaces two injector positions.

Any combination of three detectors can be installed with the following exceptions: Only two TCD or PFPD detectors can be installed. If two standard TCDs are installed, then no other detectors can be accommodated. However, a dual TCD (two cells in one housing) is available as a Custom Solution which allows installation of another detector, such as an FID, behind it.

The methanizer typically occupies the same location as one of the detectors.

Installed options on the 3800 are generally identified by their location. The options mounted on the top of the instrument, such as those listed above, are designated as Front, Middle and Rear to coincide with their relative location or the location of their respective electronic control modules.

Installation

Site Requirements for GC Installation

Power Requirements

Power Source

Each 3800 GC requires a separate circuit with the following characteristics:

101 Vac \pm 10%, 50 or 60 Hz \pm 2%, 25 Amps, 2.5 Kilowatts

120 Vac \pm 10%, 60 Hz \pm 2%, 20 Amps, 2.4 Kilowatts

230 Vac \pm 15%, 50 Hz \pm 2%, 10 Amps, 2.3 Kilowatts

Installation Category: II

Ground

It is essential to have a safety ground connection to this instrument.

Power Cord

In Europe the instrument will be supplied with an IEC 320 style socket. The power cord assembly can be changed to suit your local power and socket requirements. In the United States and Japan the instrument is equipped with a fixed power cord and plug.

Heat Dissipation

Calculate heat dissipation using the following formula:

$$\text{Watts} \times 3.4129 = \text{BTU/hr.}$$

Actual dissipation will depend on method parameters and instrument configuration.



CAUTION

Heat from the column oven is vented through the rear of the GC. Make certain that the hot column oven exhaust is not directed onto other electronic instruments, cables or gas lines.

Fuses

There are four fuses accessible on the top of the 3800:

F1: 6.3A T, F2: 6.3A T, F3: 10.0A F, F4: 6.3A T

Space Requirements

Allow sufficient bench space to permit installation of workstations, integrators, autosamplers and other peripheral GC equipment. The table below lists the physical dimensions and weight of the GC and the peripheral instruments which may be installed near it. Allow six inches of space at the sides and rear of the GC to permit free air circulation.

The power cord, gas inlets and the optional Ethernet® communications port are located on the rear panel of the instrument. The power switch is to the rear of the top cover. Signal output connectors for peripheral instrumentation such as autosamplers and integrators are located under the left top cover of the instrument.

Table 1 Physical Dimensions of the 3800 GC System Components

Instrument	Height		Width		Depth		Weight	
	in.	cm	in.	cm	in.	cm	lb.	kg
3800 GC	20	51	26	66	22	56	95	43
CP-8400 AutoSampler	16	41	9	23	18	46	20	9
Tekmar Velocity Purge and Trap	19	48	9	23	18	46	37	16.8
Archon Purge and Trap AutoSampler	17	43	21.5	55	21	53	80	36
Genesis Headspace AutoSampler	22	56	28	72	18	46	110	50
Star Chromatography Workstation (computer with monitor, approximate values)	17	43	17	43	21	53	35	16

Environmental Requirements

Pollution degree: 2

Humidity: 5% to 95% RH

Temperature: 10 ° to 40 °C operating, -20 ° to 65 °C non-operating

The 3800 Gas Chromatograph is intended for indoor use and certified for operation up to an altitude of 2000m; however, the 3800 is designed for use at higher altitudes. Varian GCs should be protected from corrosive chemicals or gases, dust/ particulate accumulation, and direct venting of air conditioners, heaters, furnaces or fans.

Peripheral Connectors

The 3800 Gas Chromatograph is equipped with various connectors on the rear panel and top of the instrument intended for use with peripheral equipment such as autosamplers and data handling devices. The following are the standard connectors on the 3800 and their intended uses:

Rear Panel

Ethernet® Connector: BNC connector for 10 base 2 cable.
AC Power Input: 230V units only.

Top of Instrument (under detector cover)

J4

Sample Introduction Device 1, 25 pin “D” connector, typically used for autosampler control.

J5

Sample Introduction Device 2, 25 pin “D” connector, typically used for autosampler control.

J6

Analog Out, for connection to data handling devices that handle analog signals such as integrators, 15 pin “D” connector.

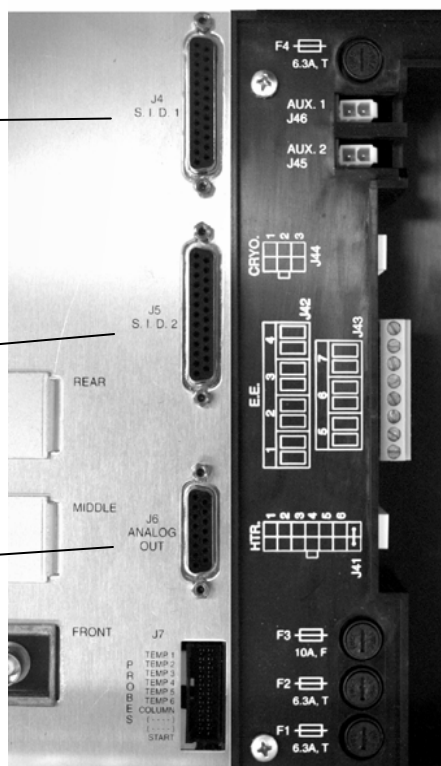

J45 and J46

Aux Output, one of these is required to power the CP-8400 AutoSampler. The other may be used for an additional powered device.

Figure 1 Connectors for Peripheral Equipment

GC Installation

Inspection The 3800 Gas Chromatograph will arrive packed in one large palletized box and one or more smaller cartons. Inspect the cartons carefully for damage or signs of rough handling. Report damage to the carrier and to your local Varian office.

Unpacking Unpack the GC and accessories carefully and transfer to the work area, using proper handling techniques. The GC should be lifted from the bottom. Inspect the GC and accessories and immediately report any damage to the carrier and your local Varian office.



WARNING

Avoid back strain or injury by following all safety precautions when lifting heavy objects.

Remove Protective Devices The instrument has been protected during shipment by various caps, plugs and restraints. Prior to operating, remove:

- Shipping dowel for oven fan motor from hole in GC rear panel
- Detector tower plugs under detector cover
- Gas bulkhead fitting plugs on rear panel
- Any plastic plugs inside the column oven

Connect Data Handling Peripherals Workstations, integrators and other data handling devices are connected to the cable connectors on the back panel or the top of the instrument.

- If the Varian Star Chromatography Workstation with 3800 control is being installed follow the installation instructions in the communications section of the 3800 Operator's manual. This installation simply involves making a connection to the Ethernet® connector on the rear panel of the GC. Additional information on 3800 Workstation control is provided in the Star Workstation documentation.
- If an analog output signal is being used, follow the specific installation instructions provided with the analog interface kit.

Select Gases

The following gases are commonly used in Gas Chromatography for the following functions. Note that the recommended purity for carrier make-up and detector fuel gases is 99.999%. In addition, the use of gas filters to remove hydrocarbons, oxygen, and water from carrier gases is recommended.

Gas	Function
He, N ₂ , H ₂ , Ar, Ar/CH ₄	Carrier gas
H ₂ , Air	Detector fuel gases
He, N ₂ , Ar/CH ₄	Make-up gas for capillary column use
Air	Air-actuated valves
LN ₂ , LCO ₂	Cryogenics

Install Gas Regulators and Set Pressures

Carrier gas, air and H₂ supplied from cylinders or manifolds should have a two-stage regulator having a zero to 100 psi low-pressure stage. Set cylinder regulator pressure to match the GC gas inlet pressures, listed below:

Gas Inlet	Pressure
Carrier gas	80 psi
Make-up	80 psi
Air	60 psi
H ₂	40 psi

Connect Gases

Follow the steps below to connect gas supplies to your 3800 GC:

1	Cut required lengths of heat-cleaned 1/8" copper tubing for the carrier and fuel gas plumbing. Clean the ends of the tubing with a metal file.
2	Slide a 1/8" Swagelok® nut, back ferrule, and front ferrule over one end of the copper tubing and attach to the outlet fitting on the cylinder regulator.
3	Push the copper tubing into the outlet fitting as far as it will go, then pull back very slightly and tighten 3/4-turn past finger-tight with a 7/16" wrench.
4	Slide a 1/8" Swagelok nut, back ferrule, and front ferrule over the other end of the copper tubing and connect it to the corresponding gas inlet on the GC rear panel.

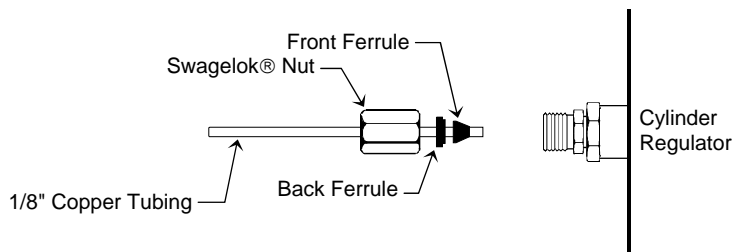

5	Push the copper tubing into the bulkhead fitting as far as it will go, then pull back very slightly and tighten 3/4-turn past finger-tight with a 7/16" wrench.
6	Make sure the gas supply control valve, which controls gas pressure to the GC, is completely closed. Open this valve slowly and monitor the pressure gauges on the dual stage regulator. The first pressure gauge should now read the pressure of the cylinder.
7	Cautiously turn the regulator valve to supply gas to the GC. Watch the pressure gauge closely and adjust the pressure according to the table above.
8	Leakcheck all fittings.

Connect GC to Power

Plug the GC power cord into an appropriate source of power. For site power requirements, refer to page 9.

Turn Power On

Turn on the GC power switch located at the top left of the GC.

- The GC display should illuminate after a few moments and go through an initialization sequence.
- The 3800 automatically enters the INSTRUMENT STATUS screen on power up. Press the SETUP key and select view SETUP to verify the 3800 configuration.

Factory Default States and Settings

Your GC is shipped from the factory with default settings. The following is relevant information on the factory default states and settings:

- When the GC is turned on, all installed heated zones except for the column oven default to power OFF.
- The default active method is method 1. The column oven defaults to power ON and a set temperature of 50 °C.
- When installed components that use a heated zone are turned ON in the active method, they default to a set temperature of 50 °C.

Quick Guide to the 3800 Keyboard and Display

Getting Around the Keyboard

The 3800 user interface is designed for maximum ease of use. The keyboard is laid out in functional sections allowing quick access to the necessary information. This subsection of the manual gives a brief overview of the functionality associated with each section of the keyboard. For more detailed information refer to the Operator's Manual: *Section 1, The 3800 Keyboard and Display*.

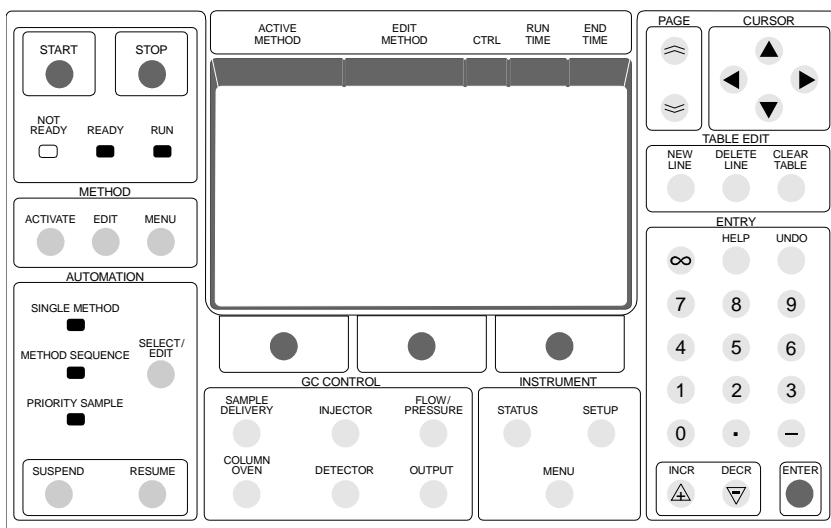
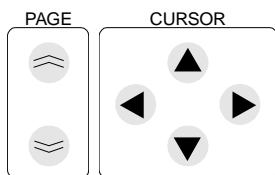

Figure 2 3800 GC Keyboard



The PAGE and CURSOR keys are used to navigate around the 3800 display and move between screens. Pressing the PAGE UP arrow key backs up to the previous page; pressing the PAGE DOWN arrow key advances to the next page. The cursor arrow keys move the screen cursor from one field to another.

To select a menu item, the cursor can be placed on the item and the ENTER key pressed or if the menu item has a number, the same menu item can be selected by pressing the appropriate number followed by the ENTER key.

Because the pertinent information cannot always fit on one screen, multiple pages are sometimes used. Where multiple pages are used this is always indicated on the title line of the display, e.g., Column Oven, Page 1 of 2.

TABLE EDIT



If you are modifying a table such as a temperature ramp table or timed events table, the TABLE EDIT keys can be used to add new lines to the table, delete the highlighted line from the table, or clear the table of all entries except for initial default conditions.

ENTRY

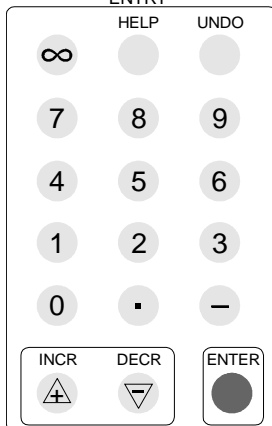

The ENTRY section of the keyboard contains the numeric keys (0 - 9, decimal point, minus sign, and infinity), the increment (INCR) and decrement (DECR) keys, the ENTER key, the HELP key, and the UNDO key. The INCR and DECR keys can be used to select from a range of values for a discrete parameter or used to increment or decrement a numeric parameter. Pressing the UNDO key will undo the last editing action. The ENTER key either advances the cursor to the next parameter if the value in the current field is not updated or updates the parameter value if a new value is entered. In the latter case the ENTER key must be pressed again to advance to the next parameter. A more convenient way to enter parameters is to use the cursor keys to move from one field to another after a parameter value has been changed.

Pressing the HELP key gives you a context sensitive explanation for the parameter at the cursor location.

INSTRUMENT

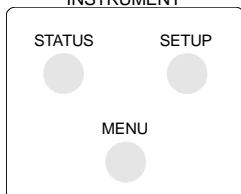

The INSTRUMENT and GC CONTROL sections are most commonly accessed. The INSTRUMENT section is where the 3800 is configured in terms of installed options and allowable operating parameters, and where an overview of instrument status can be viewed. The configuration information is accessed using the SETUP key and the instrument status information is accessed using the STATUS key.

GC CONTROL

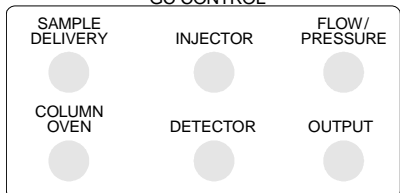

Methods are built in the GC CONTROL section. The user can build and store up to 8 methods on the 3800. Methods are built based on the components installed on the 3800 and identified in SETUP.

The following is more detailed information on the 3800 SETUP, STATUS and GC CONTROL functions.

SETUP



The Instrument SETUP key allows access to the instrument configuration screens for the purpose of viewing or modifying the 3800 configuration. Note that the 3800 has already been configured at the factory and requires only minor input from the user. At the time of installation, the SETUP screens are normally accessed by the user to update the local time and date information, update the EFC display parameters and column parameters, or verify the instrument configuration. If the instrument configuration is changed, such as when adding a field upgrade kit, the instrument SETUP screens must be updated.

The same screens are accessed whether you choose to VIEW or EDIT Instrument SETUP. However, the contents of the screens can only be changed if you choose the EDIT option. Do not choose the Edit Option unless you want to change the 3800 configuration.

As shown in the screen below, there are six menu choices in Instrument SETUP.

ACTIVE METHOD	EDIT METHOD	CTRL	RUN TIME	END TIME
Method 1	Method 1		0.00	20.00
EDIT INSTRUMENT SETUP MENU				
[1] Edit Time and Date				
[2] Edit Heated Zones				
[3] Edit EFC				
[4] Edit Column Parameters				
[5] Edit Sample Delivery Setup				
[6] Edit Ethernet Setup				
[7] Edit Miscellaneous Setup Parameters				
<input type="button" value="Save and Exit"/>				

Time and Date is used to update to the current local time and date. Selection of the desired date format and language for display is also performed here.

Heated Zones identify the type of device installed in each of the heated zones of the 3800, the upper temperature limit of these devices, their location and what type of coolant, if any, the device uses. Column oven always occupies one heated zone. The other available heated zones are numbered 1 through 6 and can be occupied by one of the following devices: 1177 injector, 1079 injector, 1041 injector, 1061 injector, 1093 injector, SPT, FID, TCD, ECD, TSD, PFPD, large valve oven, small valve oven, or methanizer. SPT is allowed only in zone 3.

The location typically refers to whether the device is installed in the front, middle, or rear position on the top of the 3800. In the case of detectors the location also refers to the relative positions of the detector electrometers installed on the main electronics board. By default, zones 1, 2, and 3 are identified as front, middle, and rear and zones 4, 5, and 6 are identified as front, middle, and rear. Zones 1, 2 and 3 are normally used for injectors and zones 4, 5, and 6 are normally used for detectors.

The temperature limit for all zones defaults to 450°C but can be set to a lower value. The coolant choices are None, LN₂, or LCO₂. Note that zones 4 - 6 cannot be used with coolant.

The following screen shows an example of a configuration screen for the 3800 heated zones. This instrument is configured with one 1177 injector, one 1079 injector, with LCO₂ coolant option, and two FIDs.

ACTIVE METHOD	EDIT METHOD	CTRL	RUN TIME	END TIME
Method 1	Method 1		0.00	20.00
EDIT HEATED ZONES				
Zone	Type	Temp Limit	Location	Coolant
Col Oven	Col Oven	450 (°C)	Col Oven	None
1	1177	450 (°C)	Front	None
2	1079	450 (°C)	Middle	LCO ₂
3	None	450 (°C)	Rear	None
4	FID	450 (°C)	Front	None
5	FID	450 (°C)	Middle	None
6	None	450 (°C)	Rear	None
Save and Exit				

EFC (Electronic Flow Control) identifies any installed EFC modules and their type. Types 1, 3, and 4 are used with inlet systems and Types 11 through 16

with detectors. Detector EFC Setup involves selecting the relevant gas type. Inlet types allow you to set the pressure display units (psi, bar or Kpa), outlet pressure and minimum flow (type 1 EFC only). Outlet pressure is used to distinguish between a column venting to atmosphere or a column venting to a vacuum source such as a mass spectrometer. The Atm setting is used for the standard 3800 detectors such as FID, TCD, ECD, TSD, and PFPD. A specific Gas Saver Flow and a timeout period may be set. **A time entry of 0 turns the Gas Saver feature off.** If a non-zero time is entered, the Gas Saver timer will start incrementing upon a method activation. If a run is not started or another method not activated before the timer expires, the set Gas Saver flow rate will be started. A message will be logged in the instrument log. **The fault is cleared by activating a method.** EFC setup for type 1 modules (CP-1177 and 1079 injectors) also contains a septum purge calibration and Splitless Vent Flow. Septum purge calibration involves measuring a flow rate at a set pressure and entering those values into the system to correctly calculate the settings for split and column flow. The Splitless Vent Flow provides a vent purge for runs in which the split valve remains closed for the duration of the run. It should be set to at least 20ml/min.

All EFC modules can be calibrated, if necessary, using the Autocalibrate softkey. This procedure should be carried out every six months, or when a new EFC module is installed. Failure to AutoCalibrate may cause a mismatch between set and actual flowrates resulting in a Not Ready condition in the 3800.

Column Parameters define values used for EFC calculations such as column length, internal diameter, and choice of carrier gas. Note that if Argon or Argon/Methane carrier gas is used, the Nitrogen option should be selected. The EFC calculations for Nitrogen, Argon, and Argon/Methane are essentially the same.

Sample Delivery has two sections, has parameters for an autosampler, if installed, and valving. For autosampler, configures which injectors the 8400 will inject into and selects the syringe capacity. For valves, defines the assignment of the seven available external events on the 3800. These are typically used with either manually controlled 1079 split valves (non-EFC) or actuators for sampling or switching valves. The setup screen identifies the valve type and default state, i.e., the state it is in when the valve is not energized. The following table summarizes the available valve types and their states. Note that the valves are normally identified on the 3800 display by their abbreviation, but when the display cursor is placed on a specific valve its full name is given on the prompt line of the display.

Valve Type	Abbr.	Default State (-)	Activated State (+)
Front Split Valve	FSV	ON (split)	OFF (splitless)
Middle Split Valve	MSV	ON (split)	OFF (splitless)
Rear Split Valve	RSV	ON (split)	OFF (splitless)
Gas Sampling Valve	GSV	Fill	Inject
Liquid Sampling Valve	LSV	Fill	Inject
Sample	S	OFF	ON
Internal Standard	IS	OFF	ON
Surrogate Standard	SS	OFF	ON
Series Bypass	SB	Series	Bypass
Backflush to Detector	BD	Forward	Backflush
Backflush to Vent	BV	Forward	Backflush
Column Selection	CS	Column 1	Column 2
Injection + Backflush to Detector	IBD	Backflush	Inject
Injection + Backflush to Vent	IBV	Backflush	Inject
Alternate Injection	AI	Column 1	Column 2
Simultaneous Injection	SI	Fill	Inject
Methanizer Bypass	MB	Series	Bypass
Event A	EA	OFF	ON
Event B	EB	OFF	ON
Event C	EC	OFF	ON
Event D	ED	OFF	ON

Ethernet setup allows entering IP Address, Netmask, and Default Gateway provided by your company network administrator. Use only if the 3800 is being connected to a company network. If you are using Star WorkStation on an isolated network (3800 connected to PC only) Do Not enter values here, instead use Star WorkStation BOOTP to assign an IP Address to the 3800.

Miscellaneous setup parameters page allows changing the polarity of the “Ready-In” sync signal. Also, if an FID electrometer is installed it allows enabling/disabling of the flameout diagnostics.

STATUS



The Instrument STATUS key allows the user to view the current status of the various components of the 3800 instrument. Several status screens are available based on component type or GC channel (front, middle, or rear). Note that the current status of individual components can also be viewed by pressing the relevant key in the GC CONTROL keyboard section.

The primary status information provided for each component using the STATUS key is the actual component temperature, carrier gas flow and pressure (if EFC is installed), and detector analog output signal. The following is an example of a status screen for a 3800 equipped with a 1177injector and FID. Note that the status screen reflects the current state

of the instrument. If the instrument is running a method, the status fields will update at a rate of once per second as the values change during the run.

ACTIVE METHOD	EDIT METHOD	CTRL	RUN TIME	END TIME														
Method 1	Method 1		0.00	20.00														
INSTRUMENT STATUS (FRONT) Page 1 of 3																		
<table border="1" style="margin-left: auto; margin-right: auto;"> <thead> <tr> <th>Component</th> <th>Status</th> </tr> </thead> <tbody> <tr> <td>1177 Oven (°C)</td> <td>250</td> </tr> <tr> <td>Column Flow (ml/min)</td> <td>1.0</td> </tr> <tr> <td>Column Pressure (psi)</td> <td>15.0</td> </tr> <tr> <td>Column Oven Temp (°C)</td> <td>50</td> </tr> <tr> <td>FID Oven (°C)</td> <td>300</td> </tr> <tr> <td>FID Output (mV)</td> <td>8.25</td> </tr> </tbody> </table>					Component	Status	1177 Oven (°C)	250	Column Flow (ml/min)	1.0	Column Pressure (psi)	15.0	Column Oven Temp (°C)	50	FID Oven (°C)	300	FID Output (mV)	8.25
Component	Status																	
1177 Oven (°C)	250																	
Column Flow (ml/min)	1.0																	
Column Pressure (psi)	15.0																	
Column Oven Temp (°C)	50																	
FID Oven (°C)	300																	
FID Output (mV)	8.25																	
○	○	○																

Note that status information may extend beyond one screen depending on the number of installed options on the GC. If this is the case, the PAGE UP/DOWN keys can be used to move between pages. Status information is presented in the order: front channel, middle channel, and rear channel.

In addition to the above status information, specific status information on individual components can be accessed by pressing the relevant key on the 3800 keyboard. For example to view the current status of the column oven, the COLUMN OVEN key is pressed. The status information is shown at the top of the display above the heavy line separating the status information from the edit method information.

The following is an example of the screen shown when the COLUMN OVEN key is depressed. The column oven status field is shown at the top of the screen. Note that the stabilization time is also shown. This represents the period of time for which the instrument will stabilize after reaching its set temperatures and before going to the ready state. You must press turn oven off if you plan to open the oven door. Press turn oven on when you close the door.

ACTIVE METHOD	EDIT METHOD	CTRL	RUN TIME	END TIME
Method 1	Method 1		0.00	23.00
Set (°C): 50			Actual (°C): 50	
Stabilization Time (min): 2.00			Column Oven: On	
COLUMN OVEN, Page 1 of 2				
Step	Temp (°C)	Rate (°C/min)	Hold (min)	Total (min)
Initial	50	-	2.00	2.00
1	150	10.0	1.00	13.00
2	250	20.0	5.00	23.00
Turn Oven ON		End Stabilization		Turn Oven Off
○		○		○

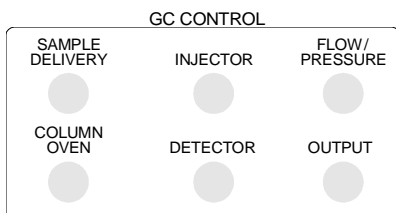

The 3800 contains eight separately programmed analytical methods. On power up the system defaults to method 1. To activate another method the user can press the ACTIVATE key in the METHOD section and select from Methods 1 - 8. To edit a method the user can press the EDIT key in the METHOD section and select the method they wish to edit. The currently active method is by default the method that will be edited unless the user chooses a different method to edit. Both the currently active method and the method being edited are identified on the top line of the 3800 display.

A method is edited by entering method parameters into the various components of the GC CONTROL keyboard section. Components are presented in the order that the sample goes through the GC system i.e. Sample Delivery→ Injector→ Flow / Pressure→ Column Oven→ Detector→ Output. The method can be edited by selecting any particular component and pressing that GC Control key or by stepping through the entire analytical method in the order shown above, i.e., if you enter values for the injector component, you are automatically taken to the Flow / Pressure component.

The following is an example of a simple analytical method consisting of a CP-1177 isothermal splitless injection using EFC pneumatics.

Note that all heated zones, with the exception of the column oven, are OFF when the 3800 is first powered up.

INJECTOR



The CP-1177 method uses two pages of screen displays, a page for turning on oven power and setting the injector temperature (isothermal), and a page for programming the split state of the injector. Note that the injector is identified by its model number and location.

ACTIVE METHOD	EDIT METHOD	CTRL	RUN TIME	END TIME
Method 1	Method 1		0.00	20.00
Set (°C): 50	Actual (°C): 50		Split Ratio: OFF	
FRONT CP-1177			Page 1 of 2	
1177 Oven power:	ON			
1177 Temperature (°C)	250			
○	○		○	

The above screen represents the temperature settings for the CP-1177 injector.

The other important CP-1177 parameter to program is the split state, which is programmed differently depending on whether the injector is equipped with manual pneumatics or EFC. The split state controls the flow of carrier gas through the injector during the analytical run. When the split state is OFF, most of the sample injected is directed onto the column. When the split state is ON, the sample is split in the injector with typically the smaller fraction entering the column and the larger fraction being vented.

The example shown below is a splitless injection with EFC pneumatics. In this case the injector is held in the split OFF state for a period of time at the beginning of the run (the sampling time). The injector is then switched to the split ON state, typically after 0.5 - 1.5 minutes, to vent the injector of any

residual solvent. After the injector has been vented, the split ratio can be reduced to conserve carrier gas. In this example the split ratio is reduced to 20:1 after 1.5 minutes. The 1177 SPLIT STATE screen is accessed by pressing the PAGE DOWN key on the 3800 keyboard until page 2 of 2 is presented.

ACTIVE METHOD	EDIT METHOD	CTRL	RUN TIME	END TIME												
Method 1	Method 1		0.00	20.00												
Set (°C): 25		Actual (°C): 250	Split Ratio: OFF													
FRONT CP-1177			Page 2 of 2													
<table border="1"> <thead> <tr> <th>Time</th> <th>Split State</th> <th>Split Ratio</th> </tr> </thead> <tbody> <tr> <td>Initial</td> <td>OFF</td> <td>OFF</td> </tr> <tr> <td>0.75</td> <td>ON</td> <td>100</td> </tr> <tr> <td>1.50</td> <td>ON</td> <td>20</td> </tr> </tbody> </table>					Time	Split State	Split Ratio	Initial	OFF	OFF	0.75	ON	100	1.50	ON	20
Time	Split State	Split Ratio														
Initial	OFF	OFF														
0.75	ON	100														
1.50	ON	20														
<div style="display: flex; justify-content: space-around; width: 100%;"> ○ ○ ○ </div>																

If the CP-1177 is equipped with manual pneumatics, the split state is programmed in the VALVE TABLE section of SAMPLE DELIVERY. For further information on this topic refer to the Sample Introduction section of the 3800 Operator's Manual.

The CP-1177 oven must be turned off if the injector is being disassembled for maintenance.

**FLOW/
PRESSURE**



If the 3800 is equipped with Electronic Flow Control, then pressing the FLOW/PRESSURE key will bring up the screens associated with programming EFC. EFC modules are identified by type and location to coincide with the sample delivery or injection device with which they are associated. Type 1 EFC is used with either the CP-1177 or 1079 Universal Capillary Injector. The following screen is a typical EFC program for type 1 EFC. In this case, a pressure program is applied to keep the column flow rate constant while the column temperature is ramped. For further information, refer to the Sample Introduction section of the 3800 Operator's Manual.

ACTIVE METHOD	EDIT METHOD	CTRL	RUN TIME	END TIME
Method 1	Method 1		0.00	23.00
Column Pressure (psi): 10.0 Column Flow (ml/min): 2				
Linear Velocity (cm/sec): 35 Total Flow (ml/min): 213				
Split Ratio: Off				
FRONT EFC, Type 1			Page 1 of 2	
Step	Pressure (psi)	Rate (psi/min)	Hold (min)	Total (min)
Initial	10.0	-	2.00	2.00
1	15.0	0.50	1.00	13.00
2	30.0	3.00	5.00	23.00
○		○		○

COLUMN OVEN



The column oven method section has two screens, one with the column oven temperature conditions and the second with fixed parameters. The temperature control screen could have one line of initial conditions in the case of isothermal operation, or a table in the case of temperature programmed operation.

The total time represents the cumulative time up to that point in the run. The Turn Oven Off softkey turns off the column oven heater and fan to allow access to the oven. Similarly, the Turn Oven On softkey is used to turn the column oven heater and fan back on.

ACTIVE METHOD	EDIT METHOD	CTRL	RUN TIME	END TIME
Method 1	Method 1		0.00	23.00
Set (°C): 50		Actual (°C): 50		
Stabilization Time (min): 2.00		Column Oven: On		
COLUMN OVEN Page 1 of 2				
Step	Temp (°C)	Rate (°C/min)	Hold (min)	Total (min)
Initial	50	-	2.00	2.00
1	150	10.0	1.00	13.00
2	250	20.0	5.00	23.00
<div style="display: flex; justify-content: space-around; margin-top: 20px;"> <div style="border: 1px solid black; padding: 5px; width: 30%;">Turn Oven ON</div> <div style="border: 1px solid black; padding: 5px; width: 30%;">End Stabilization</div> <div style="border: 1px solid black; padding: 5px; width: 30%;">Turn Oven Off</div> </div>				
<div style="display: flex; justify-content: space-around; margin-top: 10px;"> <div style="width: 30%; text-align: center;">○</div> <div style="width: 30%; text-align: center;">○</div> <div style="width: 30%; text-align: center;">○</div> </div>				

Page 2 of the Column Oven parameters consists of fixed parameters which are rarely changed. These consist of coolant on/off, coolant activation temperature, coolant time-out and stabilization. Stabilization time is the time taken for the column oven to stabilize at its set temperature before allowing the GC to go to the ready state.

DETECTOR



The 3800 detector methods generally have two method parameter pages and an additional adjustments page. The adjustments page is generally used for advanced features of the specific detectors and also for setting detector gas flows, if EFC is installed. The following is an example of an FID method. For the FID the only adjustments item is the detector time constant (Fast or Slow).

ACTIVE METHOD	EDIT METHOD	CTRL	RUN TIME	END TIME								
Method 1	Method 1		0.00	20.00								
Set (°C): 300	Actual (°C): 300		Signal (mV): 5.15									
FRONT FID Page 1 of 2												
<table border="1"> <tr> <td>Oven Power:</td> <td>ON</td> </tr> <tr> <td>Temperature (°C):</td> <td>300</td> </tr> <tr> <td>Electronics:</td> <td>ON</td> </tr> <tr> <td>Range:</td> <td>12</td> </tr> </table>					Oven Power:	ON	Temperature (°C):	300	Electronics:	ON	Range:	12
Oven Power:	ON											
Temperature (°C):	300											
Electronics:	ON											
Range:	12											
IGNITE		AUTOZERO		ADJUSTMENTS								

The second page of method parameters for the FID allows the user to time program certain events such as range and autozero during the analytical run.

ACTIVE METHOD	EDIT METHOD	CTRL	RUN TIME	END TIME												
Method 1	Method 1		0.00	20.00												
Set (°C): 300	Actual (°C): 300		Signal (mV): 5.15													
FRONT FID Page 2 of 2																
<table border="1"> <thead> <tr> <th>Time</th> <th>Range</th> <th>Autozero</th> </tr> </thead> <tbody> <tr> <td>Initial</td> <td>12</td> <td>YES</td> </tr> <tr> <td>5.00</td> <td>12</td> <td>YES</td> </tr> <tr> <td>6.50</td> <td>11</td> <td>NO</td> </tr> </tbody> </table>					Time	Range	Autozero	Initial	12	YES	5.00	12	YES	6.50	11	NO
Time	Range	Autozero														
Initial	12	YES														
5.00	12	YES														
6.50	11	NO														
IGNITE		AUTOZERO		ADJUSTMENTS												
○		○		○												

Column Installation and Conditioning

Connect Column to

Your GC arrives ready for installation of an analytical column. On first installation, a new column needs to be conditioned. **Conditioning is performed with the detector end of the column unattached.**



WARNING:
BURN HAZARD

Hot surfaces are exposed.

You may need to install and condition a new column after your GC has been in use for some time. Reset all injector, detector and column ovens to $\leq 50^{\circ}\text{C}$ to avoid burn hazards when connecting column to injector and detector parts inside the oven.

Prior to installing your column, check that the factory-installed injector is equipped with the proper insert for your application. Factory-installed injectors, other than the 1041, have a glass insert suitable for a variety of applications. If your application calls for a different insert, replace the factory-installed insert prior to installing your column. Refer to the Injector section of the Operator's Manual for instructions to replace the insert. The factory-installed inserts for the injectors are shown below.

Injector	Insert Information	Part Number
1061	4 mm ID Flash (530 μ)	03-925119-43
CP-1177	4 mm ID Open single gooseneck	03-925119-27
1079	3.4mm ID Open single gooseneck	03-926119-45

Nuts and Ferrules for Capillary Columns

Capillary columns are generally installed with a capillary column nut (P/N 03-949551-00) and a single reversed ferrule, as shown in the diagram. For connection to the TCD, a special capillary adapter (P/N 03-925605-01) is used.

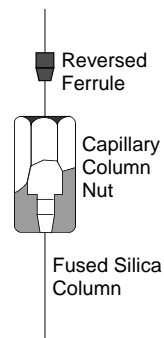

- A Quick Connect Kit (P/N 03-925355-90) facilitates easy connection of capillary column to injector and detector. The kit comes with instructions and contains: column depth scale, knurled split nuts (2), and graphite jacketed ferrules (2 each of 0.4, 0.5 and 0.8 mm ID, for 250 μ m, 320 μ m, and 530 μ m columns respectively).

Three types of ferrules are common: graphite, Vespel® or polyimide, and graphite/Vespel.

- Graphite may provide active surfaces for some ECD or GC/MS applications.
- Ferrule ID is based on the diameter of the capillary column. See the following table.

 Ferrule ID (mm)	Fitting Size (inches)	Column ID (microns)	Part Number		
			Polyimide (10/pk)	Graphite (10/pk)	Polyimide/ Graphite (10/pk)
No hole	1/16" fitting	—	SG0726841	—	28-694590-01
0.4 mm	1/16" fitting	250	28-694586-01	CR211104	CR213104
0.5 mm	1/16" fitting	320	03-908361-01	CR211105	CR213105
0.8 mm	1/16" fitting	530	28-694552-01	CR211108	CR213108

**Connect
Capillary
Column to
Injector**

Follow steps 1-7 to install a capillary column into your injector.

		1041 (530μ)	1061 (530μ)	1177/1079 (50-530μ)
1	Cut off sealed section at each end of new column.	✓	✓	✓
2	Uncoil 10 cm at injector end of column.	✓	✓	✓
3	Slide appropriate column nut and ferrule on each end of column.	✓	✓	✓
4	Make a clean cut with the cutting tool 1-2" (2-4 cm) from end of the column. Inspect the cut to verify it is square and smooth.	✓	✓	✓
5	Move nut and ferrule to within 3 cm of column end. <i>For CP-1177 injector measure and mark 3.7 cm from end.</i> <i>For 1079 injector (except "on-column" modes): Measure and mark column at 7.5 cm from end.</i> <i>For 1079 injector "on-column" modes slide the column up until it stops against the constriction in the on-column insert.</i>	✓	✓	✓ ✓ ✓
6	Holding column in one hand, gently slide column into injector until it stops OR <i>For CP-1177 and 1079 injector (except on column modes): Engage the column nut on the injector and then slide the column into the injector until the mark on the column aligns with the bottom of the nut.</i>	✓	✓	
				✓
7	Finger-tighten the column nut while holding the column in place, then tighten a further 1/4 to 1/2-turn with a 5/16" wrench.	✓	✓	✓

Nuts and Ferrules for Packed Columns

- **Metal** packed columns are usually installed with a metal 2-piece ferrule. (A commonly used metal packed column is 1/8" OD stainless steel. It uses a 1/8" ID stainless steel ferrule.)
- **Glass** packed columns are 1/4" OD and are installed with a graphite front ferrule and a metal back ferrule installed backwards. See diagram below.

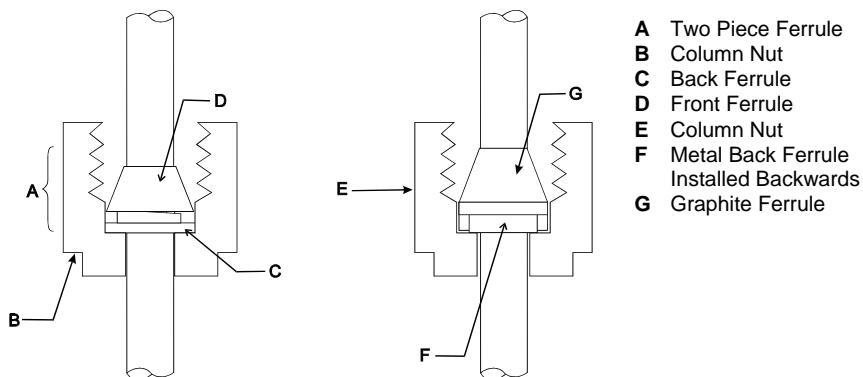

Connect a Packed Column to the Injector

Follow the steps below to install a new packed column into your 1041 or 1061 injector. Note that the injector must first be converted for packed column use by installing the appropriate adapters.

1	Place nuts and ferrules on both ends of column as shown in the previous diagram.
2	If your column is metal, insert it into the injector fitting and gently push until it stops. Manipulate the column so the detector end points to the detector <i>OR</i> If your column is glass, insert it into the injector, rotate it slightly so the detector end is out of alignment with the detector and push gently until the end is near but not touching the oven ceiling.
3	Hold the column in place and thread the nuts by hand.
4	Tighten the nut finger-tight, then give it a further 3/4-turn with a small wrench.

Varian Test Column

At points throughout this manual, specific values and conditions are given for the analysis of Varian Test Samples on Varian Test Columns. The following table provides information on Varian Test Columns.

Varian Test Columns

<i>Column Description</i>	<i>For use with Injector Models</i>	<i>Part Number</i>
Packed 50 cm x 1/8" OD stainless steel 5% OV-101.	1041/1061 Packed Adapters	03-912300-30
Capillary 15M x 250 id CP-Sil 5 CB fused silica.	CP-1177 or 1079	CP8510
Capillary 10M x 530 id CP-Sil 5 CB fused silica	1041/1061	CP7620

Identify Carrier Gas Controls and Turn on Flow

Gases are plumbed at the factory through the rear bulkhead fittings into the inlet manifold, then to the pneumatic controls in the pneumatics compartment. The pneumatic controls can be either electronically controlled (EFC) or manually controlled and are different for each injector system.

If your injector model is a ...

1041/1061

Carrier gas flow is regulated by a ...

Type 3 EFC or type 4 EFC with valving.

CP-1177 or 1079

Type 1 EFC **or** Flow controller (controls flow into injector) *and a* Back pressure regulator (controls flow through column)

- Carrier gas flow is adjusted at the user interface for EFC or at the pneumatics panel for manual pneumatics. For manual pneumatics carrier gas systems, identify the controls for carrier gas flow at the pneumatics panel for your injector system. These pneumatic controls are identified by their location, i.e., front, middle, rear.
- Turn on carrier gas flow by adjusting the manual flow controller or setting a positive pressure or flow on the EFC system.
- Verify that there is a positive pressure on the pneumatics panel pressure gauge or EFC status screen.

Split Vent Flow and

Whether you are making an injection in the split or splitless mode, a split vent flow rate needs to be set. In this example the column flow is set to 1

Septum Purge Flow

mL/min, the split vent flow is set to 100 mL/min corresponding to a split ratio of 100. A split ratio of 100 means that for every ml of gas through the column, 100 mls will flow out the vent. The split state is set in the INJECTOR section of the 3800 method if EFC is installed or in the VALVE TABLE section of SAMPLE DELIVERY if manual pneumatics are installed. In addition to a split state a septum purge flow rate should also be set. The following information is for setting a split vent flow rate with EFC installed. For either a CP-1177 or 1079 with manual pneumatics see the INJECTOR section of the Operator's Manual for further information.

1. Press the FLOW PRESSURE key and set the appropriate head pressure for your analytical column.
2. Press the INJECTOR key in the GC CONTROL section of the 3800 keyboard and select either the CP-1177 or the 1079 injector by location.
3. Press the PAGE down key to access the SPLIT STATE screen.
4. When Electronic Flow Control is installed, in addition to programming the split state, the split ratio can also be programmed.
5. Set the initial split state to ON and set the split ratio to 100.
6. Turn off the column oven by pressing the Column Oven key on the keypad and then pressing the softkey to turn off the column oven. Open the column oven door and adjust the septum purge needle valve located above the column oven until the flow rate is in the range 3 - 5 mL/min. For EFC equipped systems this value has to be entered in the septum purge calibration routine. Use the following procedure to carry out septum purge calibration:
 - Press the STATUS key and note the current column pressure for the channel you are using (front, middle, or rear).
 - Select the edit SETUP option and select EFC. Select the injector you are setting up by specifying the location (front, middle or rear).
 - Press the SEPTUM PURGE CALIBRATION softkey. You will be prompted to enter the injector pressure and septum purge flow rate. Enter the pressure value noted above and the septum purge flow rate measured earlier. The septum purge calibration is completed automatically when you press the "Save and Exit" softkey.

The CP-3800 will restart at this point.

Set Carrier Gas Flow Rate to Condition Column

To condition the column, flow rates need only be approximate. For packed columns and large bore (0.53 mm ID) capillary columns set the flow rate to 15 - 30 mL/min. Press the FLOW / PRESSURE key, select the appropriate injector by location, and set the initial flow to 15 - 30 mL/min (15 mL/min for a large bore column and 30 mL/min for a packed column).

Use the following guide to set an appropriate column flow for either the CP-1177 or the 1079 injector with narrow bore capillary columns. With manual pneumatics the pressure is set using either the CP-1177 or the 1079 back pressure regulator on the pneumatics panel. If the Capillary Injector has EFC press the FLOW / PRESSURE key, select the appropriate injector by location and set the pressure as follows:

<i>Column ID</i>	<i>Head Pressure</i>
250 μm	25 psi
320 μm	15 psi
530 μm	5 psi

Note for Capillary Column Users

Verify gas is flowing through the column by dipping the detector end of column into a beaker containing a solvent, such as isopropanol. Positive carrier gas flow should be indicated by a stream of bubbles.

Conditioning the Injector and Column

It is important to establish the maximum recommended conditioning temperature for the installed column. This information is provided with the column or can be obtained from the column manufacturer. The maximum allowable temperature for the column does not have to be used for conditioning purposes. In general the column should be conditioned at 20°C above the maximum temperature used in the analytical method, or 20°C below the maximum operating temperature of the column, whichever is lower.



CAUTION

A GC column may be irreversibly damaged if it is heated with air or moisture present in the pneumatic system. It is important to purge the column with inert carrier gas before heating the column. After the column flow is established, allow the carrier gas to purge through the column for 15 - 20 minutes before heating it.

In this example the injector and column are conditioned at 250°C for two hours. The column is programmed to 250°C at 5°C/min as a gentle temperature program is generally recommended for column conditioning. After this conditioning is complete, allow the column oven to cool and re-tighten the column nut attaching the column to the injector. This is especially important when vespel ferrules are used.

To condition the injector press the INJECTOR key in the GC CONTROL section of the 3800 keyboard. Set the injector temperature to 250 (initial temperature for a 1079). If either a CP-1177 or a 1079 injector is being used, ensure that the initial split state is ON and that no program is present to time program the split state (the split state table should consist only of the initial line). Verify that the split ratio is set to 100.

To condition the column press the COLUMN key in the GC CONTROL section of the 3800 keyboard and build the following column oven method.

Initial Column Temperature: 50 °C
 Hold Time: 5 min
 Step 1 temperature: 250 °C
 Step 1 ramp rate: 5 °C/min
 Step 1 Hold Time: 120 min

When the 3800 reaches the READY state indicated by the READY LED being lit, press the START key to begin the conditioning process.

**Connect
 Capillary
 Column to
 Detector**

After the column has been conditioned, follow the steps below to connect the capillary column to the detector.



**WARNING:
 BURN HAZARD**

Hot surfaces are exposed.

1	Check that the capillary column nut and ferrule are installed on the column. Note that if the TCD is used with capillary columns, a special capillary adapter (PN 03-925605-01) is used on the TCD inlet. <i>DO NOT use graphite ferrules with the ECD.</i>
2	Uncoil about 20 cm from end of column.

3	Move the column nut and ferrule to within 5 cm of the column end. Find the column insertion depth for your detector in the diagram below. Measure the correct distance from the end of the column and mark this distance. Refer to diagram below for correct distances. <i>DO NOT let the column nut and ferrule fall past this mark. The marking medium can contaminate the ferrule.</i>
----------	---

Column Insertion Depths for Varian Detectors

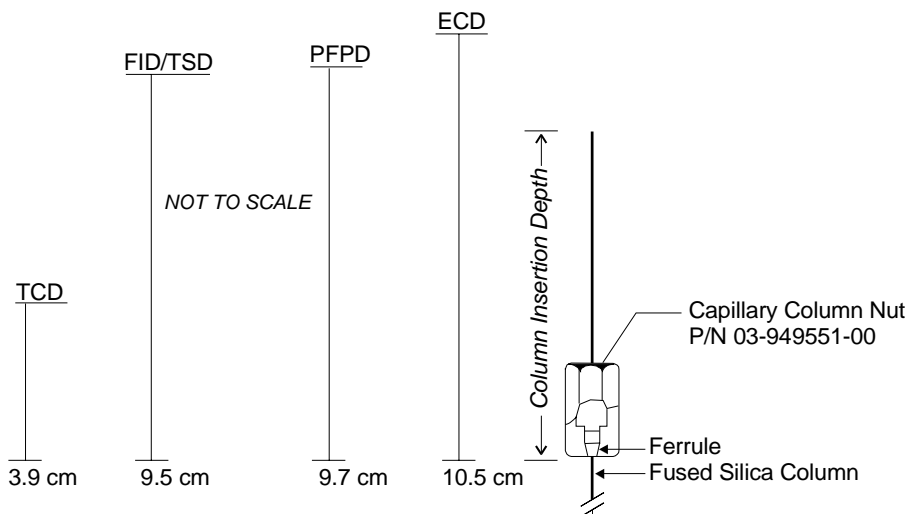

4	Place the column into the base of the detector.
5	Thread the capillary column nut and ferrule finger-tight.
6	Gently slide the column into the detector until the mark on the column aligns with the bottom edge of the column nut.
7	Continue to hold the column as you tighten the nut just enough to hold the column firmly in place and to create a good seal.

Connect Metal Packed Column to Detector

After the column has been conditioned, follow the steps below to connect your metal packed column to the detector. Note that the appropriate packed column adapter must be installed.



**WARNING:
BURN HAZARD**

Hot Surfaces are Exposed.

1	If using a detector other than TCD, locate the packed column detector adapter in the Packed Column Kit and install on the inlet to the detector. The TCD inlet is designed for packed column installation.
2	Insert the open end of the packed column into the detector inlet or adapter, and push until it reaches a stop.
3	Hold the column in place and finger-tighten the column nut. Then, using two 7/16" wrenches, tighten 3/4-turn past finger-tight. On subsequent installations, tighten the nut 1/4 to 1/2-turn past finger-tight.

Check for Leaks

Inspect your GC system for leaks before heating. An electronic leak detector is the most reliable method to check the injector and detector fittings for carrier gas leaks.



CAUTION

Never use soaps, such as Snoop®. These may contaminate the system and cause permanent damage to capillary columns. If a liquid leak detector is desired, try a 50/50 mixture of isopropanol/water.

Basic Operation

IMPORTANT NOTE: At points throughout this section, specific values and conditions are given for analysis of the Varian test samples on Varian test columns. Your analytical column and application may require different values and conditions. Please ascertain the range of operating temperatures for your analytical column and make sure your settings are within this range.

Setting Carrier and Detector Gas Flow Rates

The following table indicates the typical values for carrier and detector gas flow rates. For practical purposes a generalized carrier gas flow rate of 2 mL/min is used for capillary columns. Note that the carrier gas and make-up combined flow is typically 30 mL/min.

Table 2 Flow Rates for Carrier and Detector Gases for the 3800 Gas Chromatograph

Detector	Carrier Gas	Carrier Gas Flow Rate (mL/min)		Make-Up Gas	Make-Up + Carrier Gas Flow Rate (mL/min)	Detector Gas Air 1 (mL/min)	Detector Gas Air 2 (mL/min)	Detector Gas H ₂ (mL/min)
		Packed	Capillary					
ECD	N ₂ or Ar/CH ₄	30 ±1	1 - 15	N ₂ or Ar/CH ₄	30 ±1	—	—	—
FID	N ₂ , H ₂ or He	30 ±1	1 - 15	N ₂ or He	30 ±1	300 ±10	—	30 ±1
TCD*	N ₂ , He or H ₂	30 ±1	1 - 15	Same as Carrier Gas	30 ±1	—	—	—
PFPD	N ₂ , He or H ₂	30 ±1**	1 - 10	None	—	17 ±1	10 ± 1	13 ±1
TSD	N ₂ or He	30 ± 1	1 - 15	Same as Carrier Gas	30 ±1	175 ±10	—	4 ±0.2

***TCD Reference Flow** – Rate for carrier gas flow through the reference cell is 30 ±1 mL/min.

** **PFPD with packed columns** – an effluent splitter is used to reduce the carrier flow to the detector to < 5 mL/min.

The following instructions are for instruments configured with manual pneumatics. Gas flows for detectors with EFC are set in the Adjustments Section of the detector method.

Follow the steps below to set all gas flow rates on the 3800 Gas Chromatograph. Flows are typically set with carrier gas first followed by make-up and detector fuel gases. The most convenient way to measure or verify gas flows is at the detector exit. Adapters are provided in the individual detector accessory kits for this purpose. Note, however, that the most accurate method to determine FID and TSD flows is at the flame tip after removing the tower.

1	Attach a bubble or digital flowmeter to the detector outlet using the appropriate adapter.
2	Turn off make-up and detector gases at the pneumatics panel. For a needle valve this is accomplished by turning the needle valve cartridge knob fully clockwise. For a flow controller this is accomplished by turning the flow controller knob fully counter-clockwise or until the turns counting dial reads zero.
3	Observe reading on flowmeter. Ensure it is within the range described in the table for carrier gas flow rates.
4	Adjust the carrier gas flow using the manual pneumatics controls on the pneumatics panel or by adjusting the Electronic Flow Control to achieve the desired flow rate.
5	For a capillary system, turn on the make-up needle valve and adjust to achieve the desired flow rate. The combined carrier and make-up flow should be 30 mL/min. Adjustment is done with a small flat screwdriver inside the needle valve cartridge knob.
6	Turn on the relevant detector fuel gases in the sequence hydrogen followed by air. Use the table below to calculate the combined flows for the specific detector. For the TSD adjust the hydrogen flow controller until the turns dial reads 400.

<i>Detector</i>	<i>Carrier + make-up</i>	<i>Carrier + make-up + hydrogen</i>	<i>Carrier + make-up + hydrogen + air1</i>	<i>Carrier + make-up + hydrogen + air1 + air2</i>
FID	30	60	360	
TSD	30	34	209	
PFPD	2	15	32	42

Condition the GC System

As the injector and column were conditioned earlier, this procedure represents a quick conditioning of the entire GC system including the detector. Follow the steps below to build an analytical method to condition the GC system.

1	Press the INJECTOR key in the GC CONTROL section of the 3800 keyboard and verify that the injector temperature is 250°C. If the injector is either a CP-1177 or a1079 verify that the initial split state is ON and that there is no split time program. Set the split ratio to 100.
2	Press the COLUMN key and set the initial column oven temperature to 250°C.
3	Press the DETECTOR key and set the detector oven temperature to 300°C. If the detector is an FID, wait for the detector zone to get above 100°C and then press the ignite softkey to ignite the flame.
4	Allow the system to condition for one hour.

Build a Method to Analyze a Test Sample

The conditions for running a test sample depend on the sample chosen. The test sample is typically one of the following:

- the column test mixture supplied by the column manufacturer,
- a Varian Test Sample, or
- a test mixture you select as an indicator of system performance for a particular analysis.

Method to Analyze a Varian Test Sample on a Varian Test Column

Varian Test Samples

<i>For use with ...</i>	<i>Sample Composition</i>	<i>Part Number</i>
ECD	33 ppb Lindane and Aldrin in iso-octane	82-005048-02
FID (Packed Column)	0.03% C14, C15, C16 in iso-octane	82-005048-00
FID (Capillary Column)	0.003% C14, C15, C16 in iso-octane	82-005048-07
TCD	0.3% C14, C15, C16 in iso-octane	82-005048-01
PFPD	0.002% n-dodecanethiol, tributyl phosphate and methyl parathion, and 0.4% n-pentadecane in iso-octane	82-005048-03
TSD	2 ppm azobenzene and methyl parathion, 4 ppm malathion, and 4000 ppm heptadecane in iso-octane	82-005048-04

Note: These conditions may not conform to the requirements of your analytical column. Do not exceed your column's T_{max} . See Column Manufacturer's specifications for your column.

For 1041 and 1061 Injectors

	ECD	FID	TCD¹	TSD	PFPD
Initial column temp (°C)	80	80	80	80	80
Initial column hold time (min)	1	1	1	1	1
Final column temp (°C)	200	200	200	200	200
Final column hold time (min)	5	5	5	5	5
Initial column temp (°C) (Isothermal operation)	190	140	140	175	175
Initial column hold time (min) (Isothermal operation)	15	15	15	15	15
Injector temp (°C)	220	220	220	220	220
Detector temp (°C)	300	300	220	300	300
Range	10	10	0.05	12	10
Initial Autozero	On	On	On	On	On
TSD bead current (amps)				3.0 ±0.3	

¹**TCD Reference Flow** – Rate for carrier gas flow through the reference cell is 30 ±1 mL/min.

For 1177 and 1079 Injectors

	ECD	FID	TCD ¹	TSD	PFPD
Initial column temp (°C)	80	80	80	80	80
Initial column hold time (min)	1	1	1	1	1
Program 1 final temp (°C)	200	200	200	200	200
Program 1 ramp rate (°C/min)	20	20	20	20	20
Program 1 hold time (min)	5	5	5	5	5
Injector temp (°C)	220	220	220	220	220
Detector temp (°C)	300	300	220	300	300
Range	10	11	0.05	12	10
Initial Autozero	On	On	On	On	On
TSD bead current (amps)	-	-	-	3.0 ±0.3	-
Injection mode	Splitless				
Initial split state	OFF				
Step 1 time (min)	0.75				
Step 1 split state	ON				
Step 1 split ratio	100				

¹TCD Reference Flow – Rate for carrier gas flow through the reference cell is 30 ±1 mL/min.

Prepare the Test Sample

You are now ready to prepare your sample. For preparation of samples for automated injection, please refer to the CP-8400 AutoSampler manual , P/N 03-914852-00.

You may inject your sample neat or diluted in a solvent. The Varian PFPD test sample should be diluted 1:20 in iso-octane if you intend to use it for a splitless injection. The choice of solvents depends on a number of factors, including component solubility, type of detector, and polarity of the analytical column. Select solvents to match the polarity of your column.

Solvents for GC

Following are some recommended solvents for non-polar, intermediate, and polar phase columns.

Recommended Solvents for Gas Chromatography

Column Phase	Recommended Solvent	Boiling Point (°C)
<i>Non-Polar</i> <ul style="list-style-type: none">• 100% Methyl• 5% Phenyl, 95% Methyl	<ul style="list-style-type: none">• Pentane• n-Hexane• Cyclohexane• Iso-octane• Benzene• Toluene• Ethyl Ether• Methyl tert-butyl ether• Methylene Chloride• Chloroform• Carbon Disulfide	36.1 69.0 80.7 99.3 80.1 110.6 34.6 55.2 39.8 61.2 46.5
<i>Intermediate</i> <ul style="list-style-type: none">• 50% Phenyl, 50% Methyl	<ul style="list-style-type: none">• Ethyl Acetate• Acetone• Methyl iso-butyl ketone• Acetonitrile	77.0 56.5 127.0 81.6
<i>Polar</i> <ul style="list-style-type: none">• Polyethylene Glycol	<ul style="list-style-type: none">• Methanol• Ethanol• 2-Propanol• n-Butanol	64.7 78.5 82.5 117.7

Sample Volume and Injection Rate

The quality of your chromatogram can be greatly affected by the sample volume and injection rate. These vary according to the type of injector and column you are using. Shown below are some recommended sample volumes and injection rates. Draw the appropriate volume of sample into your syringe and inject at specified rate.

Injector	On-Column, Flash Vaporizing (1041/1061)	Split (1079, 1177)	Splitless (1079, 1177)
Column	<i>For</i> Large-bore Capillary Columns (0.53 mm ID) Packed Columns	<i>For</i> All Capillary Columns	<i>For</i> All Capillary Columns
Sample Volume in μL	0.1–2 Large-bore Capillary 1-5 Packed Columns	0.2-2	0.2-1
Injection Rate, in $\mu\text{L}/\text{sec}$	0.5-5 Large-bore Capillary 1-10 Packed Columns	50 for CP- 8400 A/S 10 for 8200 A/S	1 for CP- 8400 A/S 10 for 8200 A/S

Inject the Test Sample

Use 1 μL of the Varian test sample for all detectors. In addition, if you are using a PFPD, make a 1:20 dilution of the test sample in iso-octane. With the READY light on at the GC and the appropriate volume of test sample in your injection syringe, you are ready to make your injection. For automated injection of samples, please refer to the CP-8400 AutoSampler manual.

- To inject your sample, insert the syringe needle into the injector inlet, press the syringe barrel against the injector switch and depress it completely, simultaneously pressing down the syringe plunger. Remove the syringe from the injector immediately.
- The RUN light comes on and stays on until the analysis ends. The run may be stopped by pressing the STOP key.

- Compare the resulting chromatogram with your known test chromatogram.
- If you are analyzing the Varian Test Sample on a Varian Test Column, you may compare your resulting chromatogram with the appropriate test chromatogram in the Detector section of the Operator's Manual. The retention times will be close to those shown in the manual. The peak heights may be considerably different.
- Failure to duplicate the results you expected may indicate an installation, operation or instrument problem. This problem must be corrected before proceeding.

Maintenance

Overview

It is important for the GC user to learn general maintenance techniques and carry these procedures out on a regular basis. Some common GC maintenance procedures are changing septa and injector inserts, checking for leaks, conditioning columns and changing filters. In this section maintenance information is presented under four headings: general GC maintenance, injector maintenance, column maintenance and detector maintenance.

Note that many maintenance procedures, such as repair or replacement of electronic components, should be performed by a qualified Varian service representative. For maintenance problems where mechanical or electrical assemblies need to be repaired or replaced please call your local Varian service center.

There are certain maintenance tasks that should be carried out on a routine basis. These regular procedures are done to ensure that the 3800 Gas Chromatograph will continue to operate at optimum performance. The following is a brief summary of some common maintenance tasks and their typical frequency:

<i>Maintenance Task</i>	<i>Frequency</i>
Change septa	Typically 50 - 100 injections
Check column nuts are tight	Daily
Condition column	Daily or as required
Change injector inserts, if necessary	Weekly
Check gas supplies	Weekly
Leak check	Monthly
Change gas cylinders	Quarterly or as required
Condition system	Semiannually
Clean detectors	When performance deteriorates
Replace gas purifiers	Annually or as required
Perform AutoCalibrate (EFC)	Semi-annually

General GC Maintenance

The common general GC maintenance tasks are checking and changing gas supply cylinders, leak checking, and changing gas purifier filters. These should be performed at the frequency suggested above. The following procedures are critical to the successful long term operation of a Gas Chromatograph. It is very important to leak check the system on a routine basis and to ensure the quality of gas supplies, particularly the carrier gas.

Check and Renew Gas Supplies

The pressure of the various GC gas supplies should be checked on a weekly basis and the following guidelines used for frequency of renewing supplies:

Carrier gas: The carrier gas supply cylinder should be changed when its pressure drops below 200 psi. This ensures that high purity carrier gas is always supplied to the instrument. With typical usage on one Gas Chromatograph an A-size cylinder of carrier gas should last for three to six months. Note that this usage includes also using the carrier gas as the supply of make-up to the detectors. When a new cylinder is installed the regulator and tubing should be purged with carrier gas before connecting to the GC. This will avoid introducing a large amount of air into the GC.

Detector fuel gases: The typical detector fuel gases are hydrogen and air. These should be changed when the supply pressure drops below 200 psi. Typically an A size cylinder of hydrogen used on one GC with one Flame Ionization Detector lasts about six months. However, due to the high flow rate of air used in a Flame Ionization Detector this supply will need renewing more frequently. For this reason it is worthwhile to consider a clean supply of compressed air for FID equipped instruments.

Leak Check

Leak checking is one of the most important maintenance tasks that is carried out on a Gas Chromatograph. The following information refers to general leak checking procedures for the 3800 Gas Chromatograph. Specific information regarding individual 3800 components will be presented in the relevant part of this maintenance section.

Leaks in the GC system can lead to poor chromatographic performance or damage components such as the analytical column. The presence of oxygen in the GC carrier gas at elevated temperatures can lead to permanent column phase degradation. While the use of an oxygen filter on the carrier supply to the instrument can help, leaks downstream of the filter are generally more likely to be the problem.

The use of soap-based leak detection fluids is not recommended for a high performance capillary Gas Chromatograph due to the danger of introducing contaminants into the system. If leak detection fluids are being used they should only be used outside the Gas Chromatograph, i.e., to verify there are no leaks in the plumbing to the Gas Chromatograph. If a leak detection fluid is being used inside the Gas Chromatograph, an alcohol such as isopropanol or a 50:50 mixture of isopropanol and water should be used. Use a dropper or syringe to place a few drops of leak detection fluid on the desired fitting and monitor the area for bubble formation.

The most important step in leak checking is to verify that the GC system can hold pressure. This is done by removing the column from the injector, sealing all exits from the injector and pressurizing the system. Use the following procedure to leak check 3800 injectors:

Note: *When conducting leak check procedures it is important to completely seal all carrier gas exits, including septum purge and split vent outlets. If more than one injector is present, then the outlets of all the injectors must be sealed. The following procedure refers to one injector but should be duplicated for every injector on the 3800.*

1	Set the column oven and the injector zone temperatures to 50°C and allow them reach this temperature. This allows safe handling of injector surfaces.
2	Remove injector septum nut and install a new septum. An older septum can often be the source of a substantial leak.
3	Remove the column from the injector. Use the appropriate nut and ferrules to seal the base of the injector. For packed column systems use a 1/4" Swagelok blank off plug (P/N SWB400P). For capillary systems use a capillary nut (P/N 03-949551-00) with a no hole ferrule (P/N 28-694590-01).
4	If the injector is either a CP-1177 or a 1079, then the septum purge and split vent outlets must be sealed. The septum purge outlets are located on the top frame surrounding the column oven, behind the column oven door. The split vent outlets are located on the left side panel of the 3800. Seal the septum purge by removing the outlet fitting from the septum purge valve and replacing it with a blank off plug (P/N SWB200P). Seal the split vent outlet by installing a Swagelok union on the outlet tube and sealing it with a blank off plug.

5	With all outlet ports plugged, pressurize the system to 20 - 30 psi. This can be accomplished by adjustment of manual pneumatic controls or Electronic Flow Control (make certain that the split ratio is turned to off, constant flow is not selected, and the septum purge valve, if appropriate, is turned off). For information on setting carrier gas pressure see the Basic Operation section of this manual.
6	Shut off the carrier supply at the source and monitor the displayed pressure at the GC for 15 minutes. The pressure should not drop more than 0.5 psi in 15 minutes.

Leak checking ensures that there are no leaks in the GC system up to and including the injector assembly. If the indicated pressure on the GC drops by more than 0.5 psi during the 15 minute test period, this indicates that there is a positive leak in the system. Finding such a leak, particularly if it is a small leak, can be very difficult. In general the best approach is to systematically go through the pneumatic system from the source and tighten each fitting until the leak is eliminated. It is important to note that leaks are often found in the carrier gas supply to the GC.

Locate leaks with an electronic leak detector or leak detection fluid. An electronic helium leak detector is available from Varian (P/N CP87610). This device can detect helium concentration in the air as low as 2 ppm and is very effective at identifying the precise location of a helium leak from a GC system.

Gas Purifier Replacement

The most common gas purifiers used in gas chromatography are moisture traps for removing water vapor, hydrocarbon traps for removing low levels of hydrocarbon contaminants and oxygen traps for removing low levels of oxygen. In general the choice of filter depends on the application and detector used. Carrier gas should contain less than 1 ppm oxygen, moisture and trace hydrocarbon contaminants. A moisture and a hydrocarbon filter are recommended for general applications to maintain detector background levels at their lowest possible level. If the detector used is an ECD or MS an oxygen filter should be employed as well.

Carrier gas filters are typically located on the side or at the rear of the 3800. Varian supplies several types of carrier gas purifiers. These include a hydrocarbon trap, moisture trap, and oxygen trap. While the choice of purifier depends on the individual configuration and performance expectations, the following configuration is recommended for maximum carrier gas purity and protection.

The carrier gas should first pass through a hydrocarbon trap, then a moisture filter, and then an oxygen trap. As moisture reduces the effectiveness of an oxygen trap, a moisture trap should always be placed in front of an oxygen trap. The moisture trap should also be changed immediately when it changes color to prevent breakthrough of moisture to the oxygen trap.

The minimum recommended carrier gas purifier configuration is a moisture and hydrocarbon trap. This configuration can be used with routine GC analyses using FID, TCD, TSD and PFPD detectors. If an ECD or mass spectrometer is being used, an oxygen trap should also be added. For trace analysis the combination of hydrocarbon trap, moisture trap and oxygen traps should be used.

To install or replace the Gas Clean filter cartridges: remove new filter from sealed bag. Unscrew the ring on the filter base, lift up the filter cartridge. The base contains check valves that shut off flow when the cartridge is removed. Place ring over new cartridge, press and hold cartridge to base and engage retaining ring.

The following are the gas purifiers available from Varian.

<i>Purifier</i>	<i>Part Number</i>
Indicating oxygen trap	CP-17970
Indicating hydrocarbon trap	CP-17972
Indicating moisture trap	CP-17971

Injector Maintenance

The injector is the component of the Gas Chromatograph that requires the most frequent maintenance. This is due to the fact that the sample is deposited in the injector, thus leading to potential contamination and build up of non volatile deposits. The most frequent injector maintenance is septum replacement. In addition insert replacement and injector cleaning are very common. As septum replacement is common to all liquid injectors on the 3800 this procedure is presented first, followed by specific maintenance procedures for the individual injectors.

Septum Replacement

The injector septum is an expendable part and must be replaced on a routine basis. The frequency of replacement depends on the number of injections and whether the injections are by hand or with an autosampler. In general the septum should be replaced every 50 - 100 injections or when symptoms of a septum leak are seen. These symptoms include changing retention times, reduced detector response or a drop in column head pressure. The latter symptom is not always valid as some injectors, such as the 1079, are pressure controlled. With a pressure controlled injector, the column head pressure will remain constant even if a leak is present.

Use the following procedure to change a septum on any Varian injector:

1	Cool the column oven and injector oven to 50°C. This ensures safe handling of injector parts and protects the column from elevated temperatures while it is exposed to air.
2	Turn off the carrier gas supply to the injector to prevent the septum from being inadvertently ejected due to carrier gas pressure.
3	Remove the injector nut by turning it counterclockwise.
4	Remove the old septum using metal tweezers or a septum pick (P/N 72-000084-00). Do not to handle any internal parts of the injector with hands or gloves.
5	Install the new septum, again using tweezers to avoid contaminating the injector.
6	Replace the injector nut and tighten it finger-tight until you feel resistance from the septum, then tighten an extra 1/4 turn. Turn on the carrier gas supply.

On occasion to save time you may want to change a septum while the injector is hot. Use an injector wrench (P/N 03-908423-00) to remove and reinstall the injector nut. In all instances the column oven should be cool before removing the injector nut.

CP-1177 Injector

The CP-1177 is a Split/Splitless capillary injector. Typically, to change from Split operation to Splitless may involve changing the injector insert. The insert should also be cleaned or replaced on a routine basis. This is especially important when dirty samples are being analyzed.

After prolonged use, the CP-1177 glass insert may need to be removed either:

To clean the current glass insert for reinstallation in the CP-1177 Injector,
or To replace the current glass insert with a new insert.

Refer to the figure below when removing and/or replacing the glass insert.

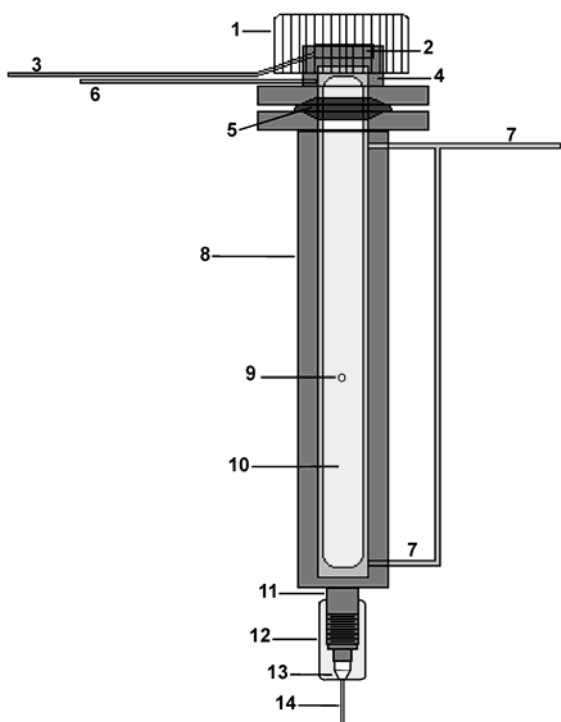

Figure 3 CP-1177 Injector - Cross-Sectional View

- | | | | |
|---|------------------------------|----|----------------------|
| 1 | Injector Nut | 8 | Injector Body |
| 2 | Septum | 9 | Point of Injection |
| 3 | Septum Purge | 10 | Glass Insert |
| 4 | Septum Purge Head | 11 | Column Guide |
| 5 | Insert Seal | 12 | Capillary Column Nut |
| 6 | Carrier Gas Inlet | 13 | Vespel® Ferrule |
| 7 | Split Vent (upper and lower) | 14 | Fused Silica Column |

Tools Required

- Tweezers or septum pick (P/N 72-000084-00)
- Injector nut wrench (P/N 03-908423-00)
- Flat-blade screwdriver (long handle)
- Clean laboratory tissue



**WARNING:
BURN HAZARD**

The injector nut may be hot. Lower the injector temperature to 50°C and permit the injector nut to cool before proceeding.

Remove the Glass Insert

Follow these steps to remove the glass insert from the CP-1177 Injector.

1	Use the injector nut wrench to remove the injector nut. Place the nut on a clean surface (e.g., clean tissue).
2	Remove the inject switch by unscrewing the retaining nut.
3	Unscrew the two captive screws holding the top of the injector to the base. Carefully move this assembly to one side. The Septum purge line and carrier gas supply lines may hinder movement of the top piece somewhat.

Note: *If the GC is equipped with an 8200 AutoSampler, to access the injector nut, push the carousel release button and swing the carousel out. If equipped with a CP-8400 AutoSampler, remove the Injector access plate by removing the two retaining screws and firmly lifting the plate. It may be hot if another injector is also installed and powered. The plate may be a little tight, do not force it off. Lift straight up, a slight back and forth rocking may help remove it.*

4	Use a laboratory tissue to grasp the glass insert and remove it from the injector body.
---	---

Replace the Glass Insert

Follow these steps to replace the glass insert in the CP-1177 Injector.

1	Using tweezers or clean lab tissue, carefully slide the new insert into the injector body. Place a new seal over the insert.
2	Carefully place the top of the injector over the insert. Tighten the two captive screws alternately for uniform sealing. Note that placing the top piece onto the body may take some care since the gas supply line and septum purge lines may have minor resistance to movement.

3	<p>Install a new septa, place the injector nut on the injector and tighten by hand until you feel some resistance, then tighten an extra 1/4 turn using the injector nut wrench.</p> <p>Note: <i>After the injector nut has been replaced, check the split vent and septum purge flow rates to ensure these values have not changed.</i></p>
4	<p>Condition the insert by setting the CP-1177 Injector to the split mode and purging with carrier gas for 30 min at 300°C.</p>

Clean the Glass Insert

Glass inserts must be clean and free from sample residue and particulate matter (such as bits of septum rubber or graphite). Follow these steps to clean the glass insert in the CP-1177 Injector.

1	<p>Remove the glass insert. It is safest to cool the injector and column ovens to 50°C before removing the insert.</p>
----------	--



**WARNING:
BURN HAZARD**

Use care when removing inserts from the injector. Inserts can be at high temperatures and are likely hot. Place hot inserts on a clean glass or metal surface only.

2	<p>To clean glass inserts, use one of the following procedures (the choice of cleaning procedure depends upon the nature of samples injected):</p> <ul style="list-style-type: none"> • Rinse the inserts with solvent or soak the inserts in hot acid. • Heat them in a glass annealing oven (to 500°C) or pass the inserts through the flame of a Bunsen burner. • Wash in a 1:1:1 mixture of methanol:methylene chloride:hexane in an ultrasonic cleaner for 30-60 min, then dry the inserts in an oven.
----------	--

Note: *For the 2 mm glass wool packed glass insert, remove the glass wool by blowing compressed gas in the end of the insert. Clean the insert following one of the procedures listed above. Repack the insert with deactivated glass wool (10-20 mg). Leave ~1.5 cm of the bottom of the glass insert unpacked. The capillary column will be inserted in this empty space when re-installed in the injector body.*

Note: *Rinsing the glass inserts with strong acids or bases or heating to a high temperature will remove the deactivation coating on the glass inserts. Rinsing the glass inserts with solvents or mixed solvents will not remove the deactivation coating.*

Deactivate the Glass Insert

Follow these steps to deactivate the glass insert in the CP-1177 Injector.

Note: This procedure can be used on all glass inserts except inserts packed with 10% OV-101 on Chromosorb W-HP (P/N 03-918956-00). Up to three inserts can be deactivated at a time using this procedure.

1	In a 10 mL glass graduated cylinder, add 0.5-1 mL of dimethyldichlorosilane. Fill to 10 mL with isooctane, hexane or toluene.
2	Cover the top of the graduated cylinder with aluminum foil and place the cylinder in an ultrasonic bath. Sonicate for 30 sec to mix the solution.
3	Add up to 3 inserts to the solution.

Note: Deactivate glass inserts only after they have been thoroughly cleaned using the above procedure.

4	Sonicate the inserts in the cylinder for 10 min. Rinse the inserts 3 times with 10 mL isooctane, hexane or toluene. Each rinse should include 2-3 min of sonication.
5	Add 10 mL of methanol and sonicate for 2-3 min. Decant the methanol and repeat the methanol rinse step.
6	Decant the methanol. Transfer the deactivated inserts to a small clean glass beaker. Cover the beaker with aluminum foil and bake at 200°C for 1 hour.
7	After the inserts cool to room temperature, store them in a clean screw cap glass vial or the original packaging.

To clean the injector body, proceed as follows:

1. Set the column oven temperature to 45 °C and the CP-1177 injector temperature to 50°C. Wait for the zones to reach their set temperatures and then turn the column oven off by pressing the “TURN OVEN OFF” softkey located in the Column Oven section of the method.
2. Use the 5/16” open-end wrench to loosen the capillary column nut.
3. By hand, carefully withdraw the fused silica column and nut from the injector assembly. Set the column nut and column end on the floor of the GC oven.



**WARNING:
CHEMICAL HAZARD**



**WARNING:
FIRE HAZARD**

Use proper eye and skin protection. Methanol and acetone are toxic and flammable chemicals. Exercise appropriate precautions when these chemicals are used.

4. Remove the injector nut, septum, and top of injector.
5. Moisten a cotton swab on a stick with methanol and gently swab center of the injector body.
6. Moisten a cotton swab on a stick with iso-octane and gently swab the center of the injector body.
7. Examine the end of the fused silica column to ensure that it has not been damaged. Slide the end of the fused silica column into the opening of the injector.
8. Gently twist the column nut in the opposite direction used to tighten the nut. Place the column nut on the end of the injector and tighten the nut. This procedure minimizes twisting the column.
9. Use the 5/16" open-end wrench and tighten with 1/6-turn to secure the column in place.
10. Replace the insert, seal, injector top, septum, and injector nut.
11. To check whether the injector is leak-tight, connect a flow meter to the split vent. Set the Relay to the split mode. If the flow meter indicates a flow less than previously measured, the injector has a leak.
12. Turn the column oven back on by pressing the "TURN OVEN ON" softkey in the column oven section of the method.

1079 Injector

The 1079 is a universal capillary injector that can be operated in several modes. These modes include split, splitless, on-column and large volume injection. Typically, to change from one mode of operation to another involves changing the injector insert. The insert should also be cleaned or replaced on a routine basis. This is especially important when dirty samples are being analyzed.

After prolonged use, the 1079 Universal Capillary Injector glass insert may need to be removed either:

- To clean the current glass insert for reinstallation in the 1079 Injector, or
- To replace the current glass insert with a new insert.

Refer to the figure below when removing and/or replacing the glass insert.

- 1 Injector Nut
- 2 Septum
- 3 Septum Purge
- 4 Septum Support
- 5 Graphite Ferrule
- 6 Carrier Gas Inlet
- 7 Split Vent
- 8 Glass Insert
- 9 Fused Silica Column
- 10 Capillary Column Nut
- 11 Vespel® Ferrule
- 12 Point of Injection

Tools Required

- Tweezers or septum pick (P/N 72-000084-00)
- Injector nut wrench (P/N 03-908423-00)
- Flat-blade screwdriver (short handle)
- Clean laboratory tissue
- Graphite ferrules (P/N 03-925342-02)
- Insert/ferrule positioning tool (P/N 03-925385-00)

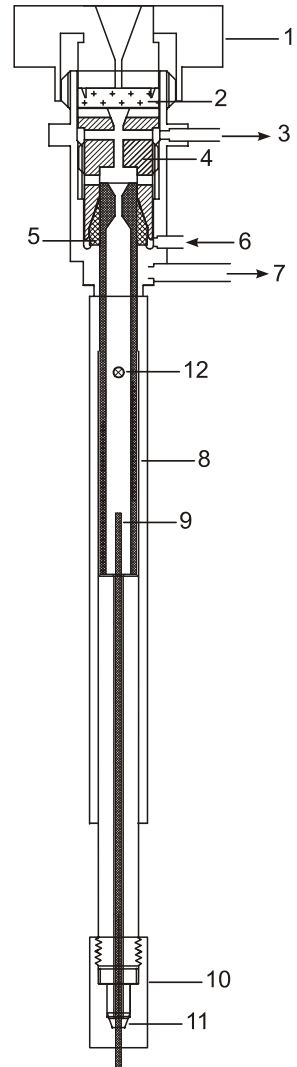

Figure 4 1079 Injector - Cross-Sectional View

Remove the Glass Insert

Follow these steps to remove the glass insert from the 1079 Injector.

1	Use the injector nut wrench to remove the injector nut (Item 1). Place the nut on a clean surface (e.g., clean tissue).
----------	---



WARNING: BURN HAZARD

The injector nut may be hot. Lower the injector temperature to 50°C and permit the injector nut to cool before proceeding.

Note: If the GC is equipped with an 8200 AutoSampler, to access the injector nut, push the carousel release button and swing the carousel out. If equipped with a CP-8400 AutoSampler, remove the Injector access plate by removing the two retaining screws and firmly lifting the plate. It may be hot if another injector is also installed and powered. The plate may be a little tight, do not force it off. Lift straight up, a slight back and forth rocking may help remove it.

2	With tweezers or septum pick, lift the edge of the septum (Item 2). Remove the septum. Note: Replace the injector septum each time the glass insert is replaced.
3	Use a clean flat-blade screwdriver to unscrew the septum support nut (Item 4) until it is loose.
4	Remove the septum support with the tweezers or septum pick. Note: Typically, when the septum support is removed, the insert and ferrule remain in the septum support. If the ferrule and insert are in the injector body after the septum support nut is removed, use the tweezers to grasp the top of the insert and lift it from the injector body.
5	Use a laboratory tissue to grasp the glass insert and remove it from the septum support nut.
6	To remove the graphite ferrule from the glass insert, use clean lab tissues to hold the graphite ferrule (Item 5) and the glass insert. Gently turn the glass insert while you pull off the graphite ferrule. Note: The glass inserts can be cleaned and reused. Unless the graphite ferrule is obviously damaged, it can be reused as well. However, replace the 5 mm graphite ferrule after the glass insert has been changed three or four times.

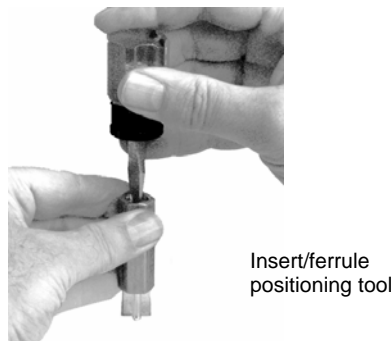
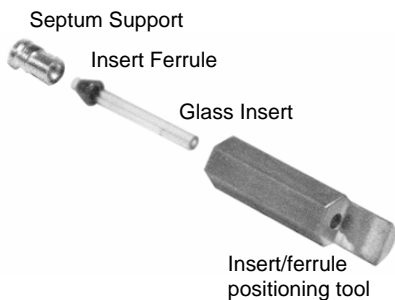

Replace the Glass Insert

Follow these steps to replace the glass insert in the 1079 Injector.

1	Use the insert/ferrule positioning tool supplied in the 1079 accessory kit to set the 5 mm graphite ferrule on the insert and in the septum support. See the above pictures for an exploded view of the tool with septum support, insert ferrule, glass insert and tool as well as the correct position of the tool when setting the ferrule. The objective is to have the ferrule set with the bottom of the insert, flush with the bottom of the tool.
2	Position the tool as shown above on a flat, clean surface. Use clean laboratory tissue on the surface. Tighten the septum support finger-tight. Holding the tool with a 5/8" wrench, give the septum support an extra 1/3 to 1/2 turn past finger-tight. Now unscrew the septum support which now has the ferrule and insert seated in it. If there is any graphite extruded past bottom of the septum support, cut it off with a blade or sharp knife. Carefully wipe off any graphite flakes which may adhere to the insert or septum support. Gripping the septum support unit with a piece of laboratory tissue, carefully put this unit in the 1079 injector and tighten the septum support 1/6-turn past finger-tight.
3	Use tweezers to place a new septum over the septum support. Note: <i>If the septum has a Teflon® face, place the Teflon face toward (down) the column.</i>
4	Place the injector nut on the injector and tighten by hand until you feel some resistance, then tighten an extra 1/4 turn using the injector nut wrench. Note: <i>After the injector nut has been replaced, check the split vent and septum purge flow rates to ensure these values have not changed.</i>
5	Condition the insert by setting the 1079 Injector to the split mode and purging with carrier gas for 30 min at 300 °C.

Clean the Glass Insert

Glass inserts must be clean and free from sample residue and particulate matter (such as bits of septum rubber or graphite). Follow these steps to clean the glass insert in the 1079 Injector.

1	Remove the glass insert. It is safest to cool the injector and column ovens to 50 °C before removing the insert.
----------	--



**WARNING:
BURN HAZARD**

Use care when removing inserts from the injector. Inserts can be at high temperatures and are likely hot. Place hot inserts on a clean glass or metal surface only.

2	<p>To clean glass inserts, use one of the following procedures (the choice of cleaning procedure depends upon the nature of samples injected):</p> <ul style="list-style-type: none">• Rinse the inserts with solvent or soak the inserts in hot acid.• Heat them in a glass annealing oven (to 500°C) or pass the inserts through the flame of a Bunsen burner.• Wash in a 1:1:1 mixture of methanol:methylene chloride:hexane in an ultrasonic cleaner for 30-60 min, then dry the inserts in an oven.
----------	--

Note: For the 2 mm glass wool packed glass insert, remove the glass wool by blowing compressed gas in the end of the insert. Clean the insert following one of the procedures listed above. Repack the insert with deactivated glass wool (10-20 mg). Leave ~1.5 cm of the bottom of the glass insert unpacked. The capillary column will be inserted in this empty space when re-installed in the injector body.

Note: Rinsing the glass inserts with strong acids or bases or heating to a high temperature will remove the deactivation coating on the glass inserts. Rinsing the glass inserts with solvents or mixed solvents will not remove the deactivation coating.

Deactivate the Glass Insert

Follow these steps to deactivate the glass insert in the 1079 Injector.

Note: This procedure can be used on all glass inserts except inserts packed with 10% OV-101 on Chromosorb W-HP (P/N 03-918956-00). Up to three inserts can be deactivated at a time using this procedure.

1	In a 10 mL glass graduated cylinder, add 0.5-1 mL of dimethyldichlorosilane. Fill to 10 mL with isooctane, hexane or toluene.
2	Cover the top of the graduated cylinder with aluminum foil and place the cylinder in an ultrasonic bath. Sonicate for 30 sec to mix the solution.
3	Add up to 3 inserts to the solution.

Note: Deactivate glass inserts only after they have been thoroughly cleaned using the above procedure.

4	Sonicate the inserts in the cylinder for 10 min. Rinse the inserts 3 times with 10 mL isooctane, hexane or toluene. Each rinse should include 2-3 min of sonication.
5	Add 10 mL of methanol and sonicate for 2-3 min. Decant the methanol and repeat the methanol rinse step.
6	Decant the methanol. Transfer the deactivated inserts to a small clean glass beaker. Cover the beaker with aluminum foil and bake at 200°C for 1 hour.
7	After the inserts cool to room temperature, store them in a clean screw cap glass vial or the original packaging.

To clean the injector body, proceed as follows:

1. Set the column oven temperature to 45 °C and the 1079 injector temperature to 50 °C. Wait for the zones to reach their set temperatures and then turn the column oven off by pressing the "TURN OVEN OFF" softkey located in the Column Oven section of the method.
2. Use the 5/16" open-end wrench to loosen the capillary column nut.
3. By hand, carefully withdraw the fused silica column and nut from the injector assembly. Set the column nut and column end on the floor of the GC oven.



**WARNING:
CHEMICAL HAZARD**



**WARNING:
FIRE HAZARD**

Use proper eye and skin protection. Methanol and acetone are toxic and flammable chemicals. Exercise appropriate precautions when these chemicals are used.

4. Remove the injector nut, septum, and septum support, with ferrule and insert attached.
5. Moisten a cotton swab and a stick with methanol and gently swab center of the injector body.
6. Moisten a cotton swab on a stick with iso-octane and gently swab the center of the injector body.
7. Examine the end of the fused silica column to ensure that it has not been damaged. Slide the end of the fused silica column into the opening of the injector.
8. Gently twist the column nut in the opposite direction used to tighten the nut. Place the column nut on the end of the injector and tighten the nut. This procedure minimizes twisting the column.
9. Use the 5/16" open-end wrench and tighten with 1/6-turn to secure the column in place.
10. Replace the septum support with insert and ferrule, septum, and injector nut.
11. To check whether the injector is leak-tight, connect a flow meter to the split vent. Set the Relay to the split mode. If the flow meter indicates a flow less than previously measured, the injector has a leak.
12. Turn the column oven back on by pressing the "TURN OVEN ON" softkey in the column oven section of the method.

1041 Injector

Hardware Replacement and Cleaning Procedures

Routine cleaning and maintenance of the 1041 Universal Injector system includes septum replacement and column conditioning. Pressure testing and leak checking procedures are included to assure proper functioning of the system.

Septum Replacement

Septum replacement represents the major part of routine chromatographic maintenance. Septum damage from the needle penetrations can be avoided by injecting into the same hole and not using syringes with needles having burrs or bends at the tip which cut the septum.



WARNING:
BURN HAZARD

The injector nut and automatic start switch assembly may be very hot during instrument operation and should not be touched with unprotected hands. Allow sufficient time for the injector nut and surrounding assemblies to cool before continuing with this procedure.



CAUTION

Handling a septum with bare fingers may result in column contamination. Use tweezers, finger cots, or gloves when installing a new septum.

1	Be sure the injector nut is cool. Unscrew the injector nut and place on a clean, uncontaminated surface.
2	Using tweezers, remove the septum, taking care not to scratch the internal surfaces of the injector.
3	Using tweezers, place a new high temperature septum in the injector. If the septum is TFE or FEP coated put that side down.
4	Replace the injector nut and tighten until resistance is felt, then tighten an extra 1/2 to full turn.

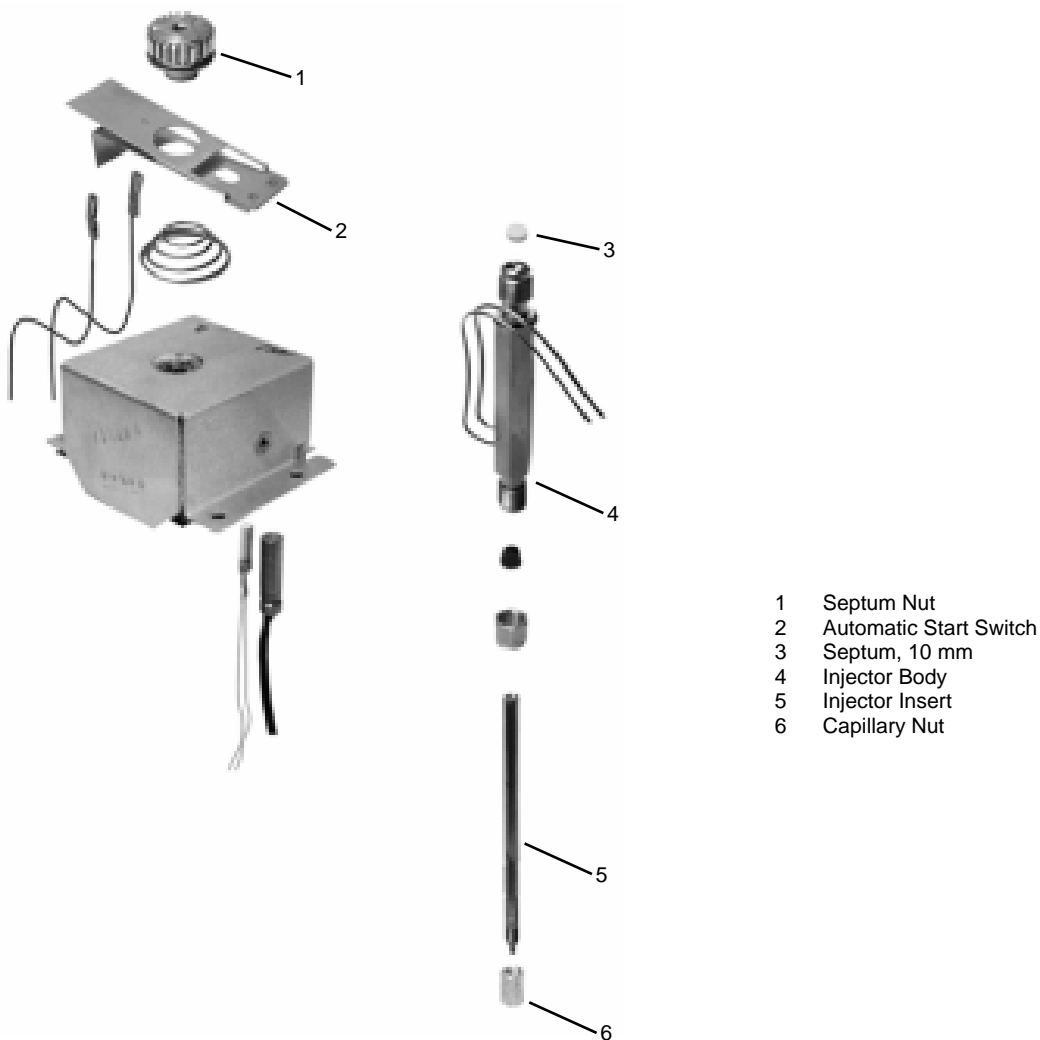

- 1 Septum Nut
- 2 Automatic Start Switch
- 3 Septum, 10 mm
- 4 Injector Body
- 5 Injector Insert
- 6 Capillary Nut

Figure 5 1041 Injector Assembly

**Needle/
Syringe
Cleaning**

For normal use, rinse the needle/syringe by slowly drawing up and quickly expelling solvent or the next sample to be used. Repeat the process several times.

Note: *When rinsing with the next sample, DO NOT expel sample back into the sample container.*

Leak Checking

Leak checking methods used with the 1041 Universal Injector are presented in order of overall sensitivity and performance. When leak checking the injector only, be sure to use the appropriate procedure.

1	Remove the test column and plug the injector outlet with a 1/16" no-hole ferrule (P/N 28-694590-01). Remove the injector nut, install a new septum, then replace injector nut and turn nut clockwise until it comes to a stop.
2	Pressurize the injector to 60 psig with carrier gas. Turn off the carrier gas flow at the supply.
3	A pressure drop less than or equal to 1/2 psig in 15 minutes is acceptable. Locate leaks with an appropriate leak detector. <i>Note: Any changes in temperature while performing this test may result in false readings due to expansion/contraction of the gas with temperature.</i>



CAUTION

Commercial soap type leak detection fluids should not be used at any point in a capillary system, since, if a leak is present, the fluid will penetrate and contaminate the system. Column performance will be degraded and a substantial period of time may be required to achieve a clean system.

4	An alternate way to leak check the injector only is to have the column installed in the injector end and the opposite column end sealed with a flame or appropriate fitting.
---	--

Gas Leak Checking

A convenient and non-contaminating way to leak test fittings and connections after installation or hardware replacement procedures is to direct a small jet of gas (butane from a disposable lighter recommended for flame ionization detectors) at the point to be tested, then use the detector, at maximum sensitivity, to detect leakage of gas into the system. Use normal column flow, a cool oven, and an operational detector. If a peak is detected in excess of the magnitude given in the following table, repair the leak.

<i>Detector</i>	<i>Gas</i>	<i>Attenuation, Range</i>	<i>Maximum Peak Size</i>
FID	Butane	16×10^{-12}	30%
ECD	Dichloromethane	2×1	50%
PFPD, Sulfur Mode	Natural Gas containing methanethiol	2×10^{-10}	50%
TSD	Dichloromethane	2×10^{-12}	2%

Visual Leak Checking

The least preferred method of leak checking is to place a drop of pure solvent (isopropyl alcohol recommended) on the suspected fitting or connection and look for bubbles.



CAUTION

Commercial soap type leak detection fluids should not be used at any point in a capillary system, since, if a leak is present, the fluid will penetrate and contaminate the system. Column performance will be degraded and a substantial period of time may be required to achieve a clean system.

Syringe Leak Checking

In some instances, non-reproducible chromatographic responses can be attributed to a worn and/or leaky syringe. The syringe must be leak tight. To check the syringe, insert the needle in an injector operating at 20 to 30 psig with a no-hole ferrule. Place a drop of solvent at suspect leak locations and look for bubbles.

1061 Injector

The 1061 is mechanically similar to the 1041 except that it uses a glass insert for flash vaporization injection. Follow the same maintenance procedures for the 1061 that are outlined above for the 1041, except in the case of changing or cleaning glass inserts.

Replacing the 1061 Glass Insert

After prolonged use, the 1061 glass insert may need to be removed for cleaning purposes or to be replaced with a new insert. Note that there are two different glass inserts, one for use with large-bore (0.53 mm ID) capillary columns and one for use with packed columns. These inserts are not interchangeable.

- Large-bore glass insert, Part Number: 03-926119-43
- Packed column glass insert, Part Number: 03-926119-44

Refer to the figure below when replacing the glass insert.

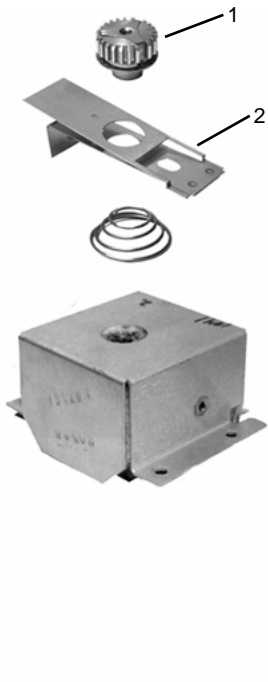

These tools are needed to replace the glass insert:

- Tweezers or septum pick (P/N 72-000084-00)
- Injector nut wrench (P/N 03-908423-00)
- Clean laboratory tissue

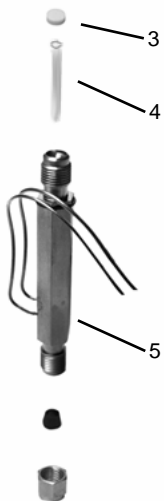

- 1 Septum Nut
- 2 Automatic Start Switch
- 3 Septum, 10 mm
- 4 Injector Insert
- 5 Injector Body

Figure 6 1061 Injector Assembly

Remove the Glass Insert

Follow these steps to remove the glass insert from the 1061 Injector.

1	Use the injector nut wrench to remove the injector nut (Item 1). Place the nut on a clean surface (e.g., clean tissue).
----------	---



WARNING: **BURN HAZARD**

The injector nut may be hot. Lower the injector temperature to 50 °C and permit the injector nut to cool before proceeding.

Note: *If the GC is equipped with an 8200 AutoSampler, to access the injector nut, push the carousel release button and swing the carousel out. If equipped with a CP-8400 AutoSampler, remove the Injector access plate by removing the two retaining screws and firmly lifting the plate. It may be hot if another injector is also installed and powered. The plate may be a little tight, do not force it off. Lift straight up, a slight back and forth rocking may help remove it.*

2	With tweezers or a septum pick, lift the edge of the septum. Remove the septum. Note: <i>Replace the injector septum each time the glass insert is replaced.</i>
3	Use tweezers to grasp the glass insert and remove it from the injector. Note: <i>The glass inserts can be cleaned and reused.</i>

Replace the Glass Insert

Follow these steps to replace the glass insert in the 1061 Injector.

1	Pick up the new insert with tweezers and place it in the injector carefully.
2	Use tweezers to place a new septum in the injector. Note: <i>If the septum has a Teflon face, place the Teflon face toward (down) the column.</i>
3	Place the injector nut on the injector and tighten by hand until you feel some resistance, then tighten an extra 1/2 to full turn using the injector nut wrench. Note: <i>After the injector nut has been replaced check the head pressure (EFC status on display or manual pressure gauge on pneumatics panel) increases to its normal value. If this does not happen there is an indication of a leak.</i>
4	Condition the insert by setting the 1061 Injector temperature to 300°C and allowing the system condition for 30 minutes.

Clean the Glass Insert

Glass inserts must be clean and free from sample residue and particulate matter (such as bits of septum rubber or graphite). Follow these steps to clean the glass insert of the 1061 Injector.

1	Remove the glass insert. It is safest to cool the injector to 50°C before removing the insert.
---	--



WARNING:
BURN HAZARD

Use care when removing inserts from the injector. Inserts can be at high temperatures and are likely hot. Place hot inserts on a clean glass or metal surface only.

2	<p>To clean glass inserts, use one of the following procedures (the choice of cleaning procedure depends upon the nature of samples injected):</p> <ul style="list-style-type: none"> • Rinsing the inserts with solvent or soaking the inserts in hot acid. • Heating them in a glass annealing oven (to 500°C) or passing the inserts through the flame of a Bunsen burner. • Wash in a 1:1:1 mixture of methanol:methylene chloride:hexane in an ultrasonic cleaner for 30-60 min, then dry the inserts in an oven.
----------	---

**Deactivate
the glass
insert**

Follow these steps to deactivate the glass insert in the 1061 Injector.

1	In a 10 mL glass graduated cylinder, add 0.5-1 mL of dimethyldichlorosilane. Fill to 10 mL with isooctane, hexane or toluene.
2	Cover the top of the graduated cylinder with aluminum foil and place the cylinder in an ultrasonic bath. Sonicate for 30 sec to mix the solution.
3	Add up to 2 inserts to the solution. <i>Note: Deactivate glass inserts only after they have been thoroughly cleaned using the above procedure.</i>
4	Sonicate the inserts in the cylinder for 10 min. Rinse the inserts 3 times with 10 mL isooctane, hexane or toluene. Each rinse should include 2-3 min of sonication.
5	Add 10 mL of methanol and sonicate for 2-3 min. Decant the methanol and repeat the methanol rinse step.
6	Decant the methanol. Transfer the deactivated inserts to a small clean glass beaker. Cover the beaker with aluminum foil and bake at 200°C for 1 hour.
7	After the inserts cool to room temperature, store them in a clean screw cap glass vial or the original packaging.

Flame Ionization Detector

When the performance of the FID has degraded you may want to replace the flame tip ferrule, or clean the deposits from the internal parts, including the flame tip.

Clean the Flame Tip and Internal Parts

If the FID noise increases with frequent spikes, the internal parts may be fouled and need to be cleaned.

To clean the flame tip and the internal parts of the FID, proceed as follows:

Note: Always handle detector components with tweezers to avoid contamination.



WARNING:
EYE HAZARD



WARNING:
FIRE HAZARD

Use proper eye and skin protection. Methanol and acetone are toxic and flammable chemicals. Exercise appropriate care when you use and dispose of these substances.

1	Remove the detector and internal parts.
2	Scrape the deposits from the bore of the collector tube, the insulator, and the metal part of the flame tip with emery cloth (e.g., SiO ₂).
3	If the flame tip is plugged, insert a wire through the flame tip orifice to clear it.
4	If you have access to an ultrasonic cleaner, clean the collector, insulator, and flame tip with distilled water.
5	Rinse the cleaned components with methanol or acetone and air dry.
6	Wipe the detector tower with acetone.
7	Clean the probe arms with methanol and air dry or dry in an air oven (maximum drying temperature of 150 °C).
8	Reinstall the detector. To prevent leaks, use a NEW aluminum seal washer each time you install the detector tower.

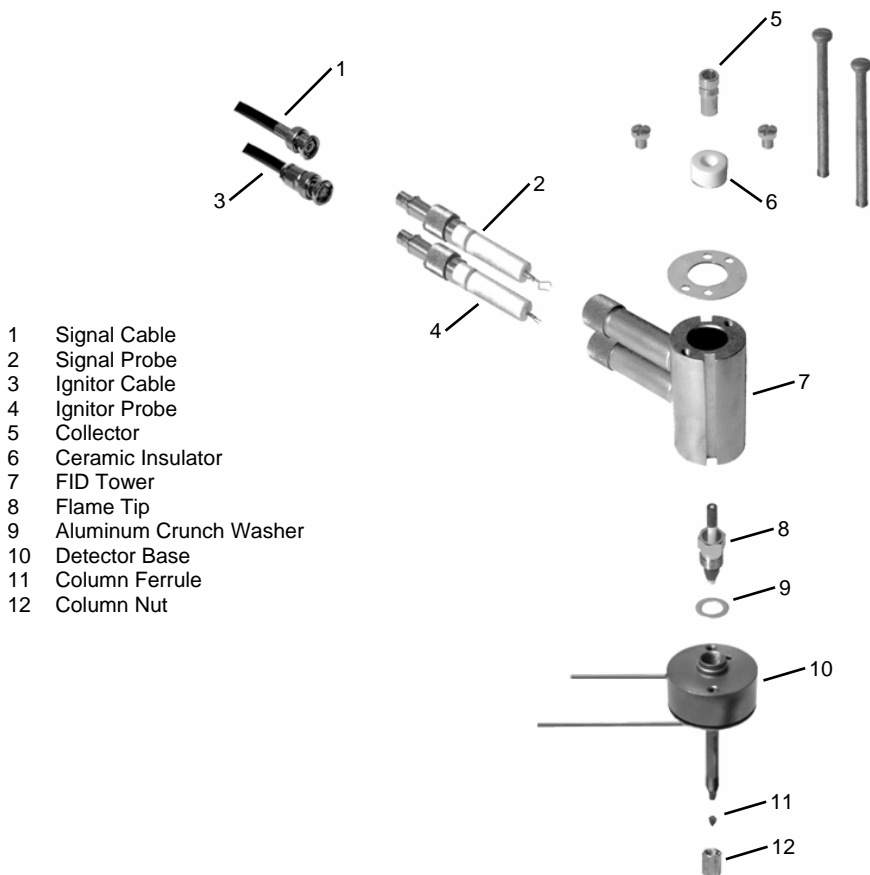

Figure 7 Flame Ionization Detector Assembly

Replace the Ferrule

After a period of prolonged use, the flame-tip ferrule may deteriorate and crack. As a consequence, a leak may develop around the base of the flame tip assembly that causes unstable baseline noise and reduced sensitivity. In this situation, or when the detector is to be operated at temperatures above 350 °C, you must replace the ferrule. Be sure to select the proper ferrule for the application. The Vespel/graphite ferrule has a maximum temperature limit of 350 °C.

Thermionic Specific Detector

Cleaning/ Maintenance

When the TSD exhibits low sensitivity or high background noise, cleaning is indicated. Visual inspection may also indicate a need for cleaning. The ceramic bead, collector, or flame tip are all parts that are deposit prone, depending on the type of samples being used. Clean these parts as indicated in the following paragraphs.

Note: Always handle detector components with tweezers to avoid contamination.

Bead Cleaning

Non-volatile deposits can be removed from the bead by gently scraping the bead surface with a sharp tool or abrasive paper. The bead should be supported while being cleaned to prevent bending the lead and cracking the ceramic coating on the leads.

Flame Tip and Internal Parts Cleaning

Follow the steps below to clean the flame tip and internal parts.



**WARNING:
EYE HAZARD**



**WARNING:
FIRE HAZARD**

Use proper eye and skin protection. Methanol and acetone are toxic and flammable chemicals. Exercise appropriate precautions when these chemicals are used.

1	Remove the detector and internal parts. Handle internal parts with tweezers and place on a clean, uncontaminated surface.
2	Clean deposits from the surface of the collector with water or abrasive paper.
3	Remove deposits which form on top of the flame tip by scraping. If flame tip is plugged, clear by inserting wire (approximately 0.012 inch diameter) into flame tip orifice.
4	Flush cleaned components with methanol and air dry.

Ferrule Replacement

If a leak develops around the base of the flame tip assembly due to a deteriorated ferrule or if the detector is to be operated at temperatures above 350°C, and results in a crack, the ferrule must be replaced. A leak at the ferrule may cause noise, instability, and loss of sensitivity. Be sure to select the proper ferrule for the application. The Vespel ferrule has a maximum temperature limit of 350 °C.

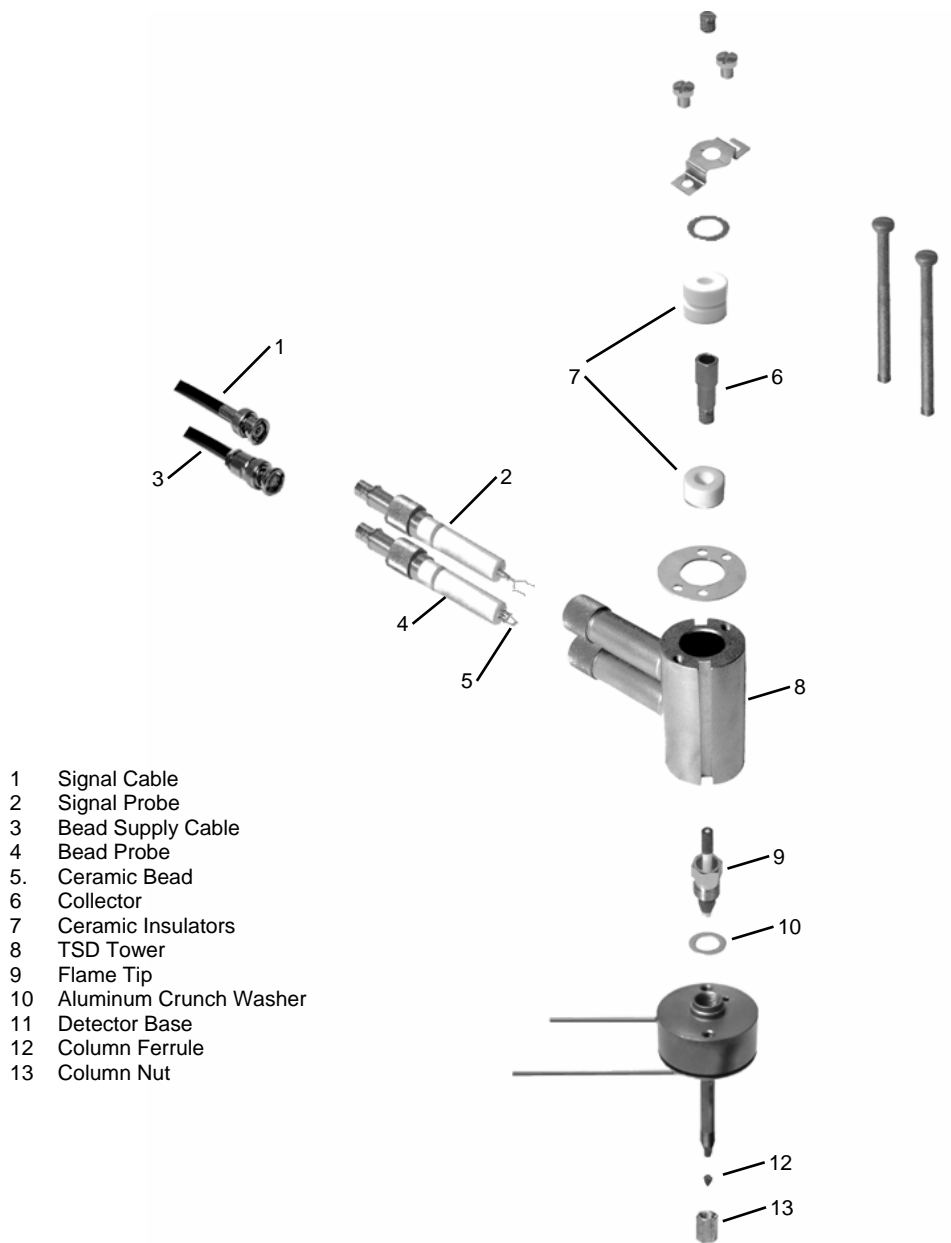

Figure 8 Thermionic Specific Detector Assembly

Electron Capture Detector

Chemical contaminants may deposit on the components of the detector assembly as the ECD is operated. In many cases, you can remove contaminants deposited on the radioactive foil or cell ceramic insulators by heating.

Refer to the Radiation Safety Manual (P/N 03-913999-00) for detector repair, radioactive decontamination, foil replacement, and leak-test information.

Note: *Although all heated zones on the 3800 have a potential upper temperature of 450 °C, Varian recommends that you do not operate the ECD above 420 °C. (The radioactive source temperature is less than 400 °C even when the detector set temperature is 450 °C.)*

Thermal Cleaning With Carrier Gas

Use N₂ or Ar/CH₄ as the carrier gas to thermally clean the ECD. Refer to Table 2 on page 39 for flow rates.

1	Remove column from the detector, cap the detector inlet using a no-hole ferrule (28-694590-01) and column nut (03-949551-00).
2	Confirm makeup gas is flowing out of the ECD vent tube, flow should be at least 30mL/min. Increase the DETECTOR TEMP to 400 °C.



WARNING: RADIATION SOURCE

Do not attempt to chemically clean the source. Submerging the cell in liquid or running a liquid through the cell will cause radioactivity to migrate, contaminate the exterior of the cell, and damage the insulators. The cleaning of the radioactive ECD source can be performed only by an NRC licensee. Cleaning of the ECD source by persons other than registered NRC licensees is strictly forbidden by law.



CAUTION

AVOID FOIL DAMAGE. The carrier gas must be flowing through the detector cell before setting the DETECTOR TEMP above room temperature. Failure to do so may damage the radioactive foil, which is not covered by warranty.

2	Monitor the output signal while the detector heats to its maximum temperature. The signal will increase initially, then gradually decrease as chemical contaminants vaporize from the detector surfaces.
3	Allow the DETECTOR TEMP to remain at 400°C until the signal reaches a stable level. A stable signal indicates that the foil has been cleaned as much as it can be by this method.
4	Set the detector at normal operating temperatures and flow carrier gas through the detector overnight. Check and readjust the Contact Potential setting if necessary.
5	If the performance of the detector is not restored by these cleaning methods, refer to the Radiation Safety Manual (P/N 03-913999-00) for information on replacement of the foil.

Thermal Conductivity Detector

The Thermal Conductivity Detector is not user serviceable and has no replacement parts. To condition the TCD, set the detector temperature to 350°C and allow it condition for 4 hours or overnight. The filament temperature should be set to zero during this procedure.

Pulsed Flame Photometric Detector

For PFPD maintenance procedures see the PFPD Operator's Manual, P/N 03-914649-00.

Parts and Supplies

- To Order Parts and Supplies ...**
- In the USA and Canada, call 1-800-926-3000.
 - In Europe, call your local Country office.
 - In the rest of the world, call your local Varian representative
 - Or, contact Varian on the Internet at <http://www.varianinc.com>

Injectors

CP-1177 Injector

Description	Part Number
Ceramic scoring wafer (for cutting fused silica columns)	01-900158-00
Capillary column nut	03-949551-00
Ferrule, no hole (package of 10)	28-694503-01
Septum pick	72-000084-00
Viton O-ring (package of 25)	88-501031-00
Graphite Seal (package of 10)	03-926119-30
Splitless insert, 2 mm ID	03-926119-24
Splitless insert, packed with deactivated glass wool, 2 mm ID	03-926119-38
Split/Splitless insert, gooseneck, open, 2 mm ID	03-925119-26
Split insert, packed with deactivated glass wool, 4 mm ID	03-926119-37
Split insert, open, 4 mm ID	03-926119-25
Split insert, gooseneck, with deactivated glass wool, 4 mm ID	03-926119-36
Split insert, gooseneck, open, 4 mm ID	03-926119-27
Double gooseneck, open, 4 mm ID	03-926119-29
SMPE insert, gooseneck, .75 mm ID	03-926119-98
Septa BTO (package of 50), 9 mm	CR298713
Septa Marathon (package of 25), 9 mm	CR239778
Septa Advanced Green 3 (package of 50) 9 mm	CR246713

1079 Injector

Description	Part Number
Ceramic scoring wafer (for cutting fused silica columns)	01-900158-00
Capillary column nut	03-949551-00
Ferrule, no hole (package of 10)	28-694503-01
Septum pick	72-000084-00
Graphite ferrule for insert, 5 mm (package of 2)	03-925342-02
Open 0.5 mm ID insert	03-925331-00
SPME open insert 0.8 mm ID	03-925330-00
Splitless insert, 2 mm ID	03-926119-47
Splitless insert, packed with deactivated glass wool, 2 mm ID	03-926119-53
Split insert, fritted, 3.4 mm ID	03-926119-46
Split insert, open, 3.4 mm ID	03-926119-45
Split insert, packed with 10% OV-101 on Chromosorb W-HP	03-926119-54
SPME insert, 0.8 mm ID	03-926119-48
Septa BTO (package of 50), 11.5 mm	CR298777
Septa Marathon (package of 25) 11.5 mm	CR239787
Septa Advanced Green 3 (package of 50)	CR246725
Septum support	03-918676-00
Insert/Ferrule positioning tool	03-925385-00

Options

Capillary Column Quick Connect Kit	03-925751-91
------------------------------------	--------------

1041/1061 Injector

Packed Column Adapter Kit for 1041, 1/8" SS columns	03-925588-91
Packed Column Adapter Kit for 1061, 1/8" SS columns	03-925588-92
Packed Column Adapter Kit for 1041& 1061, 1/4" glass columns	03-925586-91
<i>Note that these kits contain injector and detector adapters</i>	
1061 Glass insert for 0.53mm ID columns	03-926119-43
1061 Glass insert for Packed Columns	03-926119-44
Septa BTO (package of 50) 9.5 mm	CR298705
Septa Marathon (package of 25) 9.5 mm	CR239188
Septa, Advanced Green 3 (package of 50), 9.5 mm	CR246124

Detectors

Flame Ionization Detector

Flame Tip Assembly (0.02" ID)	02-001938-00
Aluminum Crunch Washer (25)	15-003347-01

Thermionic Specific Detector

TSD Bead Probe	03-906074-00
TSD Bead Probe, preconditioned	03-906074-01

Electron Capture Detector

ECD Cell with ⁶³ Ni Foil	02-001972-01
ECD Wrench	72-000081-00

Thermal Conductivity Detector

TCD Make-up Gas Option	03-925605-01
------------------------	--------------

Pulsed Flame Photometric Detector

Aluminum Crunch Washer	15-003347-00
Combustor, Quartz (2mm ID)	03-925176-00
Combustor, Quartz (3 mm ID)	03-925177-00
Filter Assembly, Sulfur	03-925151-01
Filter Assembly, Phosphorus	03-925151-02
Ignitor Assembly	03-925160-00
Combustor support, 2 mm	03-925178-00
Combustor support, 3 mm	03-925179-01
Combustor support seal	03-925138-00