

Table of Contents

1	Scope of Delivery		
2	Safety		
3	Function		
3.1	Principle of Operation		
4	Putting into Operation		
4.1	Installation Location		
4.2	Unpacking		
4.3	Setting up the Support Rod		
4.4	Attachment of the EasyClamp		
4.5	Removal of the EasyClamp		
4.6	Installation of the Reflux Glass Assembly		
4.7	Installation of the Descending Glass Assembly		
4.8	Installation of the Descending Glass Assembly with a 2 nd Cooler		
4.9	Installation of the Receiving Fixture		
4.10	Attaching and Removing Flasks		
4.11	Hose Coupling		
4.12	Operating the Shut-off tap		
4.13	Bath Replenishment (Optional)		
4.14	Reset of the over-temperature protection		
4.15	Heating Medium		
4.16	Checking Installation		
5	Operation	20	
5.1	Arrangement of the Operator Control and Display Elements		20
5.2	Adjusting the Maximum Set-Point Temperature and Automatic Lowering of the Bath in Case of a Power Interruption		20
5.3	Tips and Tricks		21
5.4	Table of Solvents		22
2	Maintenance		23
6.1	Taking Apart the Snap Flange Coupling		23
6.2	Assembling the Snap Flange Coupling		24
6.3	Removing the Evaporating Flask Seal		24
6.4	Inserting the Evaporating Flask Seal		25
6.5	Replacement of the Seals for the Distribution Head		25
6.6	Replacement of the Vacuum Seal		26
6.7	Cleaning		26
6.8	Vacuum Seal		26
6.9	Testing for Leaks		27
6.10	Customer Service		27
7	Taking out of Operation		28
8	Spare Parts and Accessories		29
8.1	Glass Assemblies D, D2, DB, DB2		30/31
8.2	Glass Assemblies R, RB, C		32/33
8.3	Miscellaneous		34
8.4	Accessories		37
9	Appendix		42
9.1	Technical Data		42
9.2	Materials Used		42
9.3	Error Messages		43
9.4	FCC requirements (for USA and Canada)		44
9.5	Declaration of Conformity		45



Read this Operating Manual through carefully before using the **Büchi** Rotavapor **R-220**. Always keep these Instructions readily available in the immediate vicinity of the unit so that they make be consulted at any time.

Chapter 2 contains important safety rules which must be observed to ensure the safe operation of the rotary evaporator.

We reserve the right to make technical changes without prior notification. No portion of this Operating Manual may be reproduced, processed using electronic or optical systems, duplicated, or distributed in any form without the prior written approval of Büchi Labortechnik AG. All rights reserved. © Büchi Labortechnik AG, 1999-2001

en, Version G (46 Pages)

Ordering No.

R-220 Operation Manual

96737

1 Scope of Delivery

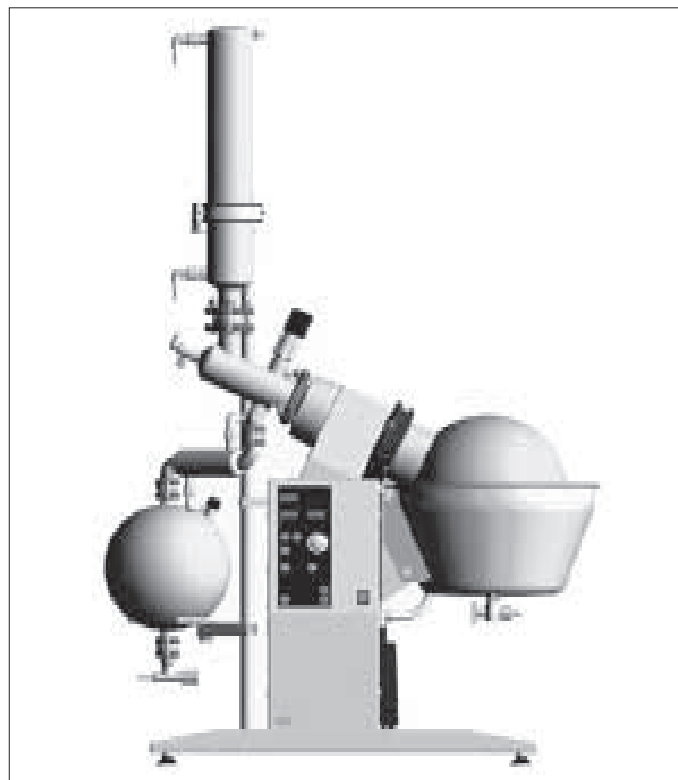

Fig. 1: R-220, Overall View

Component

- | | |
|---|--|
| 1 | Chassis, complete, with control and driving unit and with heating bath |
| 1 | 6L, 10L or 20L Evaporation flask |
| 1 | Receiving flask 1 x 10L Single receiver or 2 x 10L Interchangeable receivers |
| 1 | Glass assembly
(Refer to Chap. 4.6 - 4.8 for Figure) |

Table 1: Scope of Supply

Standard Accessories:	Ordering No.
1 Seal tool	20057
1 Operating Manual	
German	96736
English	96737
French	96738
Italian	96739
Spanish	96740

Table 2: Standard Accessories

2 Safety

This unit has been built in accordance with the latest state of the art and with recognized rules of safety. Nevertheless there are certain risks and dangers entailed with this unit:

- whenever the unit is operated by individuals who lack sufficient training;
- whenever the unit is used for some purpose other than its authorized use.

2.1 Symbols



Stop

Information on dangers that can cause serious material damage and severe personal injuries or death.



Warning

Information on dangers that can be injurious to one's health or cause material damage.



Note

Information pointing out technical requirements. A failure to observe such information can lead to malfunctions, uneconomical operation, and losses in production.

2.2 Responsibilities of the Operator

This unit may only be used by technical staff and by individuals who, based on their training or their professional experience, have a good understanding of the dangers that can arise from the its operation.

Staff who do not have this training and individuals who are currently in training must be given careful instructions. This Operating Manual should be used as the basis for such training.

2.3 Authorized Use

The rotary evaporator has been designed for use in technical laboratories and in production. It is authorized for use in applications that work with the evaporation and condensation of solvents.

It is used for:

- Evaporation of solvents and suspensions
- Drying of powders and granulates
- Re-crystallization
- Reactions under reflux
- Synthesis and Cleaning of refined chemicals
- Recycling and concentration of solvents

The authorized use of the Rotavapor also includes its care, upkeep, and careful handling in accordance with the provisions in this Operating Manual.

2.4 Unauthorized Use

Any use other than those indicated above, and any use that is not in conformity with the Technical Data is considered to be misuse. The operator himself bears sole responsibility for all damage or injuries arising from any such use.



The following applications in particular are strictly forbidden:

- The production and processing of materials that can cause spontaneous reactions, e.g., explosives;
- Working without the evaporation flask being immersed in the water bath (risk of breakage);
- The drying of hard, brittle materials (e.g., stones, soil samples) that might cause damage to the receiving flask;
- Sudden shock-cooling of the evaporating flask.



The Rotavapor R-220 is not intended for work done under overpressures.

2.5 Basic Dangers

Basic dangers arise when working with the following:

- The hot water or oil bath (risk of being scalded);
- Contaminated solvents that produce residues from distillation which could cause spontaneous reactions (e.g., metal hydrides);
- Solvents that can produce peroxides (risk of explosions);
- Mixtures with unknown compositions or contamination;
- Damaged glassware;
- Electrostatic charges while working, e.g., during the transfer of combustible solutions and while drying powders;
- Temperatures of coolants that lie below the freezing point of the distillate (A clogging of the distillate cooler due to freezing out can result in too great an overpressure).

2.6 Safety Precautions

All regional and local laws and regulations must be observed.

The Rotavapor has been grounded internally to dissipate any electrostatic charges on it.

It is always mandatory to wear personal protective gear such as **protective eyewear** and **protective clothing**.



The machine must never be rotated without the snap flange coupling and evaporation flask being closed.

No distillation may be started unless the evaporating flask is immersed in the bath. There is always the risk that the neck of the flask might break off due to the great weight involved. There is a risk of becoming scalded while changing evaporating flasks. Wearing gloves prevents this.

Check the glass components regularly for possible damage, spreading impact marks, or cracks.



Never interrupt the grounding conductor (protective conductor). Otherwise there will be the risk of an electrical shock!

The operator bears responsibility for providing proper instruction of his operating staff. To aid him in doing this, translations of this Operating Manual are also available in several other languages. As an integral component of the rotary evaporator, this Operating Manual must be readily available at all times to the operating staff at the location where they are using the unit.

The operator must inform the manufacturer immediately of any and all events relevant to safety that occur in his use of this equipment.

2.7 Modifications

No modifications are permissible without consulting with and obtaining the written approval of the manufacturer.

No glass assemblies other than those recommended by the manufacturer may be used, nor may any glass components be put together arbitrarily.



Only those components of the rotary evaporator intended for fulfillment of its function may be installed in or removed from the unit. This may be done either by hand, or with the use of the tool supplied along with the unit. The removal of safety devices or covers using some commercially available tool is — other than for authorized commissioning personnel — strictly forbidden. Contact with parts that are electrically live may result in fatal injury!

3 Function

A vacuum rotary evaporator is used for quick single-stage distillations that treat the product gently. The process is based on the evaporation and condensation of solvents in a rotating evaporating flask.

It is possible to work under a vacuum to ensure gentler treatment of the product and increase productive output.

Distillation may be done either under a vacuum or at atmospheric pressure.

A secure closeness is guaranteed in the low pressure range.

3.1 Principle of Operation

① Evaporation Zone

The solvent in the evaporating flask is heated by the heating bath. The rotation of the evaporating flask ensures an intensive exchange of heat and mass within the contents of the flask, forming a thin film of solvent on the inner surface of the flask. This combination of turbulence and film prevents local overheating and ensures high distillation speed.

② Rotary Drive

The drive unit ensures the uniform rotation of the evaporating flask.

③ Cooling Zone

The solvent vapor flows into the cooler at a high speed. This is where the energy in the solvent vapor is transferred to the cooling medium (e.g., water). The solvent condenses.

④ Receiving Flask

The receiving flask is used to collect the condensate.

⑤ Vacuum Cover

The system pressure is reduced so as to lower the boiling point of the solvent. The reduction in thermal loading that results ensures gentle treatment of the product and offers energetic advantages.

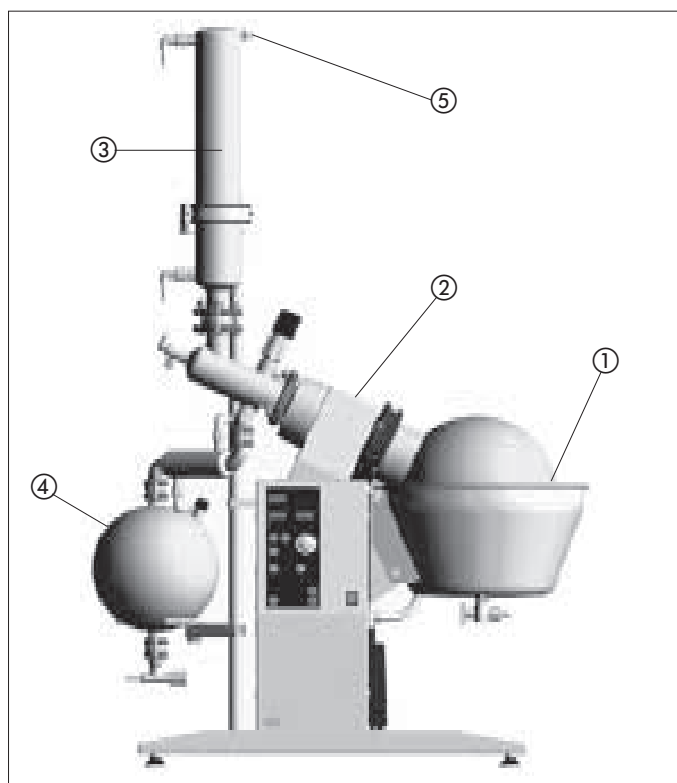

Fig. 2: Principle of operation of the R-220



The pressure (vacuum) of distillation, the temperature of the heating bath, the rotational speed, and the size of the evaporating flask all affect the evaporation output. Refer to Chapter 5.3 for how to select the optimum conditions of distillation.

4 Putting into Operation



The danger zone around the Rotavapor R-220 can extend outward by up to 10 m. When working inside this danger zone, there is a risk of damaging the glass parts, which could cause them to implode.

The electrical connection must be installed and checked by an authorized person.

4.1 Installation Location

Always set the unit up on a clean, stable, and flat surface. Never at a location where there is a great deal of personal traffic (breaking or broken glass) !

The dimensions of the rotary evaporator are:

Height:		
without trolley	Reflux	1700 mm
	Descending	1800 mm
	Bullfrog Reflux	1430 mm
	Bullfrog Descending	1550 mm
with trolley	Reflux	2300 mm
	Descending	2400 mm
Width:		
	Reflux	1100 mm
	Descending	1250 mm
	Descending, with 2 coolers	1250 mm
Depth:		
	Single receiver	550 mm
	Interchangeable receivers	650 mm

4.2 Unpacking



Take care not to break the glass when opening cartons that contain glassware.

Look for any damage after unpacking. It is important that any damage in transit be identified right when unpacking. If necessary, make an immediate assessment of the situation (Notify the post office, the railroad, or the shipping company involved). Save the original packing for possible transport at a later date.

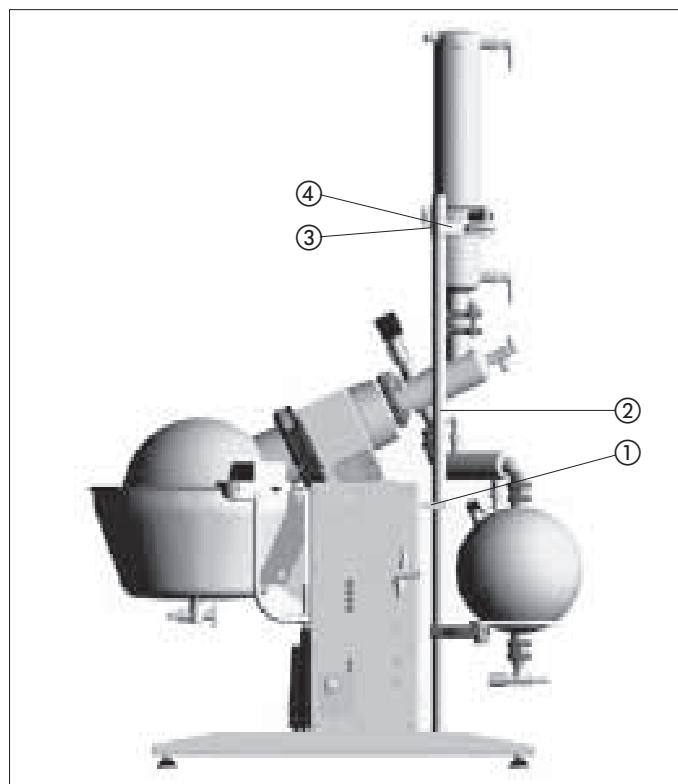

Fig. 3: Support rod

4.3 Setting up the Support Rod

- Place the support rod ② into the holder provided for it and lower it into the foot hole at the back. Fix it tight using the locking screw ①.
- Put the positioning ring ③ on over the rod, 150 mm below the upper edge.
- Lay the pivoting clamp ④ on top of the positioning ring.
- Attach the pivoting clamp for the receiving flask 200 mm above the bottom edge of the rod.

When installing an interchangeable receiver:

- Place the short support rod into the holder at the front and lower it into the foot hole. Screw it tight using the locking screw.
- Attach the pivoting clamp approx. 200 mm above the lower edge of the rod.



Fig. 4: Attachment of the EasyClamp

4.4 Attachment of the EasyClamp

- Carefully lay the EasyClamp around the glass and fold the top and bottom segments together, closing them at their open connection point.
- Insert the bolt that does not have a spacer spring, and tighten the knurled nuts slightly.
- Tighten all knurled nuts uniformly by hand.

Note:

Always tighten the knurled nuts by hand and not to the block (with the spring pressed together completely). Otherwise the prestressing will be lost.

There must always be a gap of about 2 mm between the knurled nut and the support surface.



Fig. 5: Removal of the EasyClamp

4.5 Removal of the EasyClamp

On all EasyClamp connections, **only the bolt without a spacer spring** has to be removed in order to open the connection.

- Release the knurled nuts on all (2 or 3) bolts until the springs have been relieved. Do not, however, screw the nut all the way off.
- On the bolt that does not have a spacer spring, release the knurled nut far enough (without removing it completely) so that the bolt can be tilted out and removed as a unit.
- At the connection point, which is now open, spread the top and bottom segments apart and carefully remove the EasyClamp.



4.6 Installation of the Reflux Glass Assembly

All glassware used must be intact, with no signs of cracks, spreading impact marks, or other damage. Inspect the glassware visually before installing it.

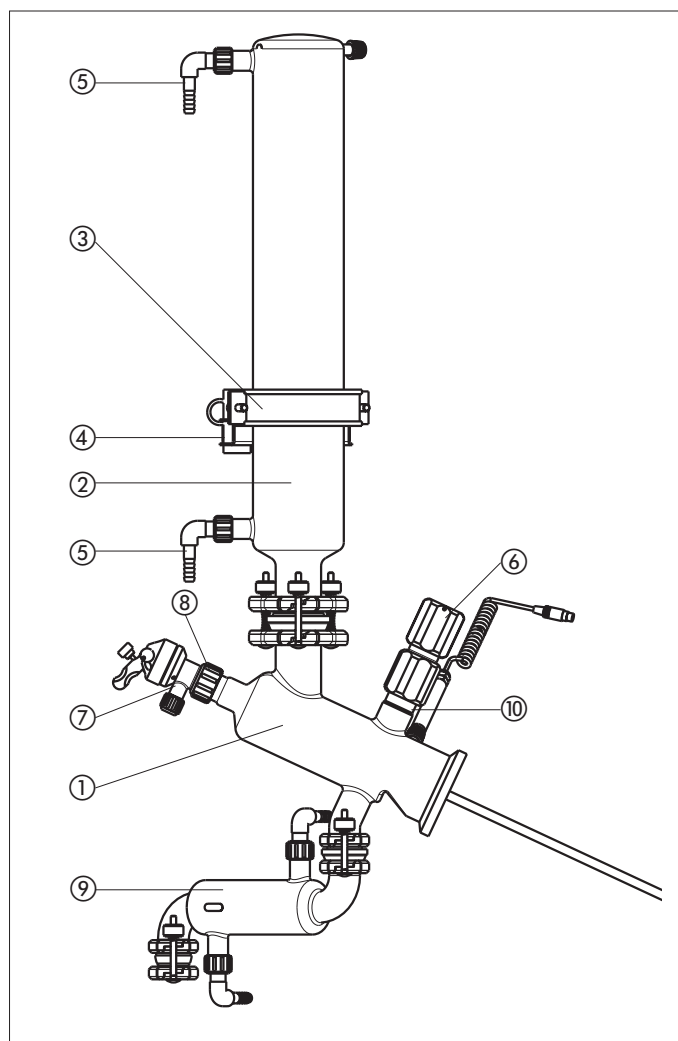

Fig. 6: Reflux glass assembly

- Fix the reflux distribution head ① in position on the gear head using a DN70 EasyClamp connection.
- Introduce the cooler ②, together with the cooler holder ③, into the pivoting clamp ④ and connect it to the distribution head (DN45 EasyClamp connection).
- Align the cooler ② in a vertical position and fix it in place with the pivoting clamp ④.
- Screw the cooling water hose nipples ⑤ onto the cooler ②.
- Insert the shut-off tap ⑥ into the distribution head ① and tighten it firmly.
- Introduce the stop cock ⑦ into the distribution head with the PTFE hose attached to it, and secure it with a standard joint clamp ⑧.
- Attach the condensate cooler ⑨ to the distributor head with a DN25 EasyClamp connection and fix it in position.
- Screw the temperature sensor ⑩ into the distribution head ①.
- Check all EasyClamp connections and tighten them evenly and in parallel.

→ The installation of the receiving fixture is described on Page 13.

4.7 Installation of the Descending Glass Assembly



All glassware used must be intact, with no signs of cracks, spreading impact marks, or other damage. Inspect the glassware visually before installing it.

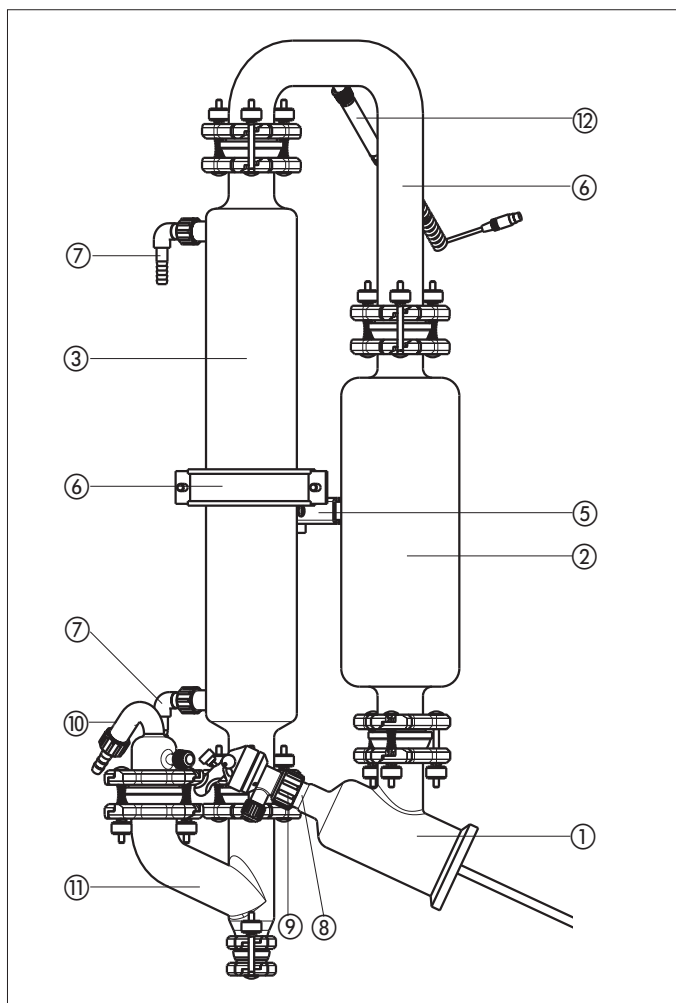

Fig. 7: Downgrade glass assembly

- Fix the descending distributor head ① in position on the gear head using a DN70 EasyClamp connection.
- Put the expansion vessel ② onto the distribution head and fix it in position with a DN45 EasyClamp connection.
- Introduce the cooler ③, together with the cooler holder ④, into the pivoting clamp ⑤ and connect it to the distribution head (DN45 EasyClamp connection).
- Connect to the cooler and the expansion vessel using the U-tube ⑥ and fix in position with two DN45 EasyClamp connections.
- Align the cooler ③ and the expansion vessel ② in their vertical positions and fix them in place with a pivoting clamp ⑤.
- Screw the cooling water hose nipples ⑦ onto the cooler ③.
- Insert the stop cock ⑧, with the PTFE hose mounted on it, into the distribution head, and secure it with a standard joint clamp ⑨.
- Fasten the vacuum connector ⑩ to the Y-connection ⑪ with a DN45 EasyClamp connection and fix the unit in place on the lower end of the cooler with a DN45 EasyClamp.
- Screw the temperature sensor ⑫ into the support connection in the U-tube ⑥.
- Check all EasyClamp connections and tighten them evenly and in parallel.

→ The installation of the receiving fixture is described on Page 13.

4.8 Installation of the Descending Glass Assembly with a 2nd Cooler



All glassware used must be intact, with no signs of cracks, spreading impact marks, or other damage. Inspect the glassware visually before installing it.

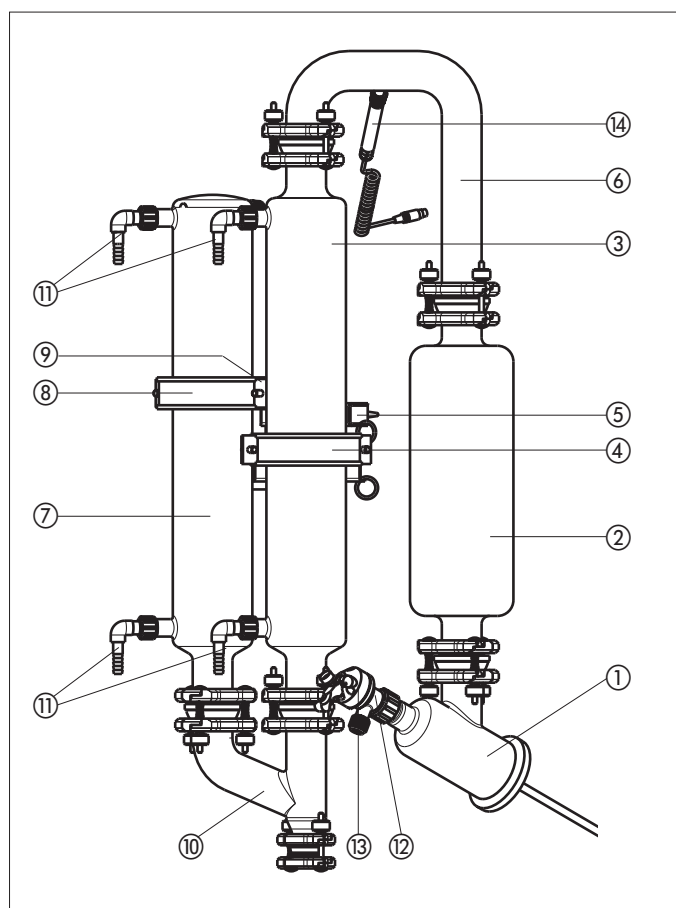

Fig. 8: Downgrade glass assembly with two coolers

- Fix the descending distributor head ① in position on the gear head using a DN70 EasyClamp connection.
- Place the expansion vessel ② on the distribution head and fix it in position with a DN45 EasyClamp connection.
- Introduce the cooler ③, together with the cooler holder ④, into the pivoting clamp ⑤.
- Connect the cooler and the expansion vessel with the U-tube ⑥ and fix them in position with two DN45 EasyClamp connections.
- Insert the second cooler ⑦, together with the cooler holder ⑧, into the pivoting clamp ⑨.
- Join the two coolers with the Y-connection ⑩ and fix them in position with two DN45 EasyClamp connections.
- Align the coolers (③ and ⑦) and the expansion vessel ② in their vertical positions and fix them in place with pivoting clamps (⑤ and ⑨).
- Screw the cooling water hose nipples ⑪ onto coolers ③ and ⑦.
- Insert the stop cock ⑫, with the PTFE hose mounted on it, into the distribution head, and secure it with a standard joint clamp ⑬.
- Screw the temperature sensor ⑭ into the support connection in the U-tube.
- Check all EasyClamp connections and tighten them evenly and in parallel.

→ The installation of the receiving fixture is described on Page 13.



4.9 Installation of the Receiving Fixture

All glassware used must be intact, with no signs of cracks, spreading impact marks, or other damage. Inspect the glassware visually before installing it.

Single Receiver

- Fasten the support ring ① to the support rod with a pivoting clamp ②.
- Screw the outlet valves ③ on the receiving flask ④ on tight using a DN25 EasyClamp connection.
- Place the receiving flask on the support ring ①.

With a reflux glass assembly:

- Bring the support up and fix the flask in position on the distillate cooler using a DN25 EasyClamp connection.

With a descending glass assembly:

- Attach the branching piece ⑤ to the opening at the bottom of the Y-connection with a DN45 EasyClamp connection.
- Insert the shut-off tap ⑥ into the branching piece ⑤ and tighten it firmly.
- Bring the support up and fix the receiving flask ④ in position on the branching piece ⑤ using a DN25 EasyClamp connection.

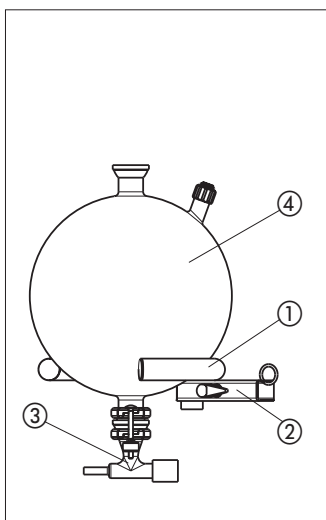

Fig. 9: Single receiver, reflux

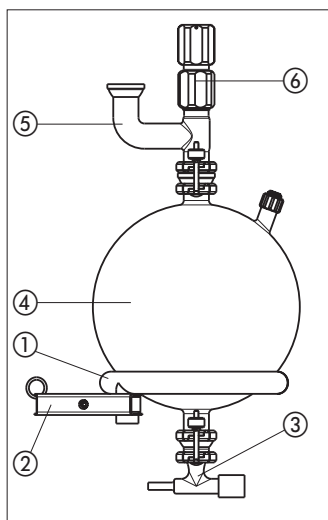

Fig.10: Single receiver, downgrade

Dual Receiver

- Fasten the support rings ① to the support rods at the front and back using pivoting clamps ②.
- Screw the outlet valves ③ firmly onto the receiving flask ④ using DN25 EasyClamp connections.
- Place the receiving flasks ④ on the support rings ①.
- Screw the two shut-off taps ⑤ into the branching pieces (⑥ and ⑦) and tighten them.
- Connect the branching pieces with a DN25 EasyClamp connection. Place them on the receiving flasks ④, and fasten them with DN25 EasyClamp connections.

With a reflux glass assembly:

- Bring the receiving flask up, and fasten the branching piece ⑦ to the condensate cooler using a DN25 EasyClamp connection.

With a descending glass assembly:

- Bring the receiving flask up, and fasten the branching piece ⑦ to the Y-connection using a DN25 EasyClamp connection.

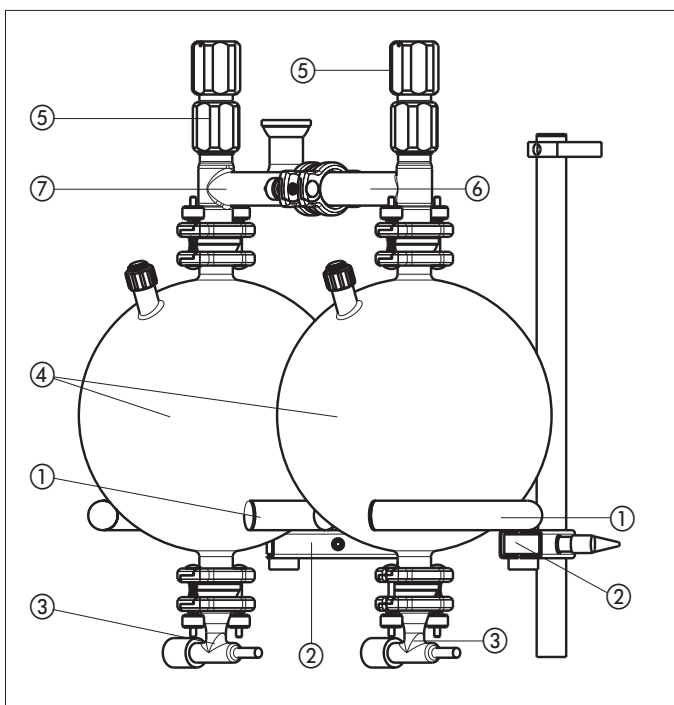

Fig. 11: Interchangeable receiver

4.10 Attaching and Removing Flasks

Bring up the flask

- With the snap flange coupling open, lay the flask in position.
- Close the first segment of the snap flange coupling (The hook must latch in).



Fig. 12: Snap flange coupling, with flask laid in place

- Close the second segment of the snap flange coupling.
- Insert the closure hook and press down the closure lever. A clear resistance must be felt when this is done. If not, readjust the tension on the closure.



Fig. 13: Closing the snap flange coupling

Adjusting the tension on the closure:
Open the closure hook up, and turn it.

Turning clockwise increases pressure
Turning counterclockwise reduces pressure

If the flange of the evaporating flask is outside of a certain tolerance, the adjustment with the hook is not possible. This evaporating flask must not be used!



Fig. 14: Adjusting the tension on the closure

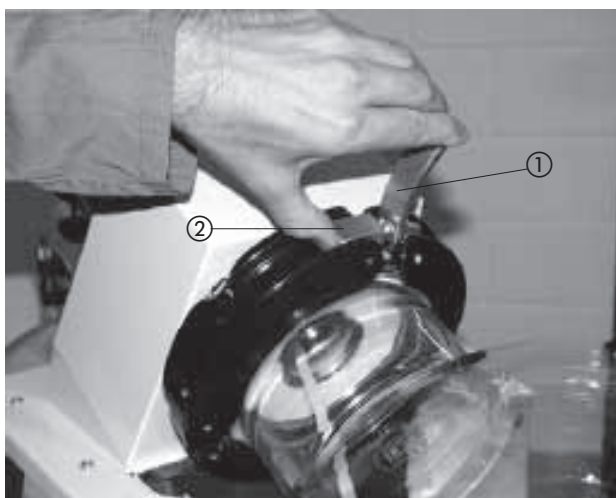

Fig. 15: Opening the closure

Removing flasks

- Place your hand under the flask to hold it from below.
- Open the closure lever ①.
- Use your thumb to release the closure hook ②.
- Flip up the first segment of the snap flange coupling.

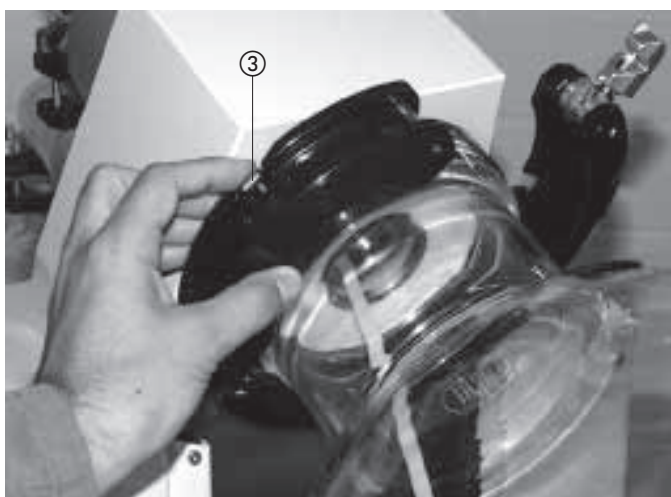
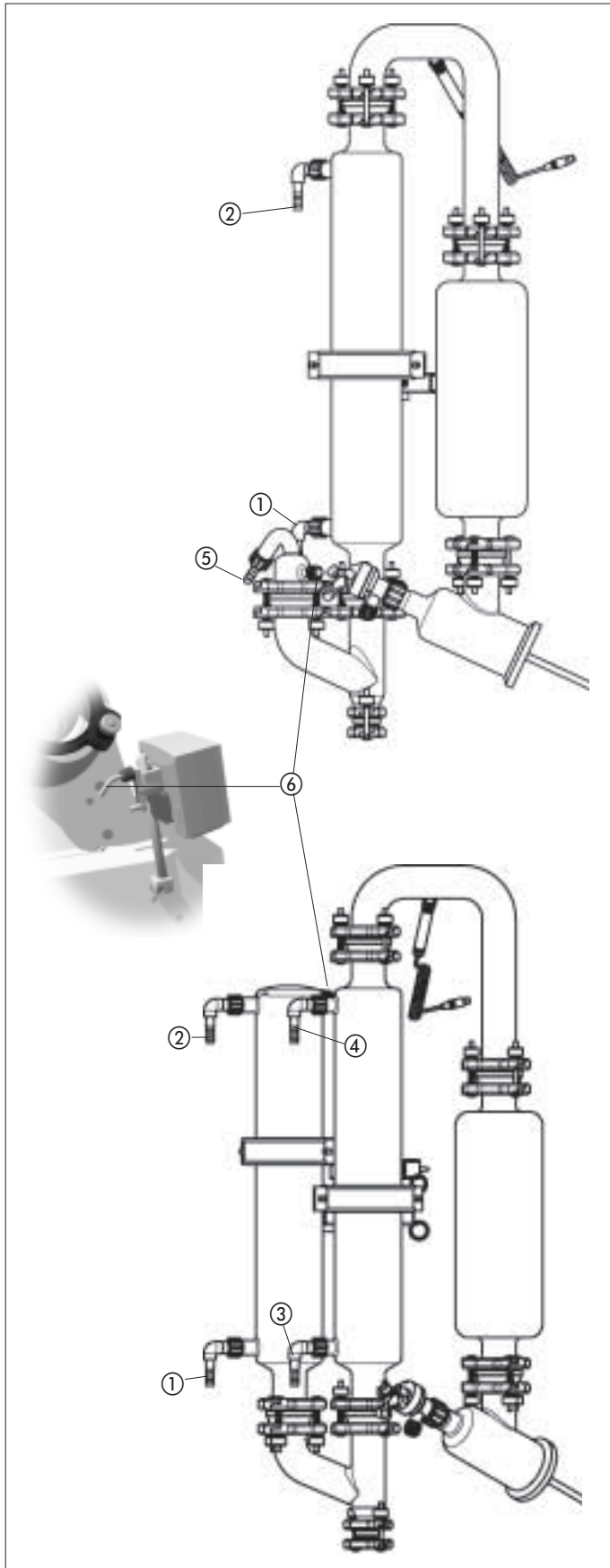

Fig. 16: Opening the second segment

- With your hand under the flask, lift it lightly slightly from below and relieve pressure on it.
- Press the hook ③ in.
- Open the second segment of the snap flange coupling.
- Lift the flask out at the top and remove it.



4.11 Hose Couplings

In general, observe the following items for all glass assemblies.

The cooling water inlet is always at the lower condenser connection.

When there are two condensers (D2 und DB2), the two condensers can be connected serially, the additional condenser being cooled first.

The following is the key for all of the hose diagrams on these two pages.

- ① Cooling water inlet for first condenser
- ② Cooling water outlet for first condenser
- ③ Cooling water inlet for second condenser
- ④ Cooling water outlet for second condenser
- ⑤ Vacuum connection
- ⑥ Vacuum controller
- ⑦ T-piece (026117)

Fig. 17: Hose Couplings 1

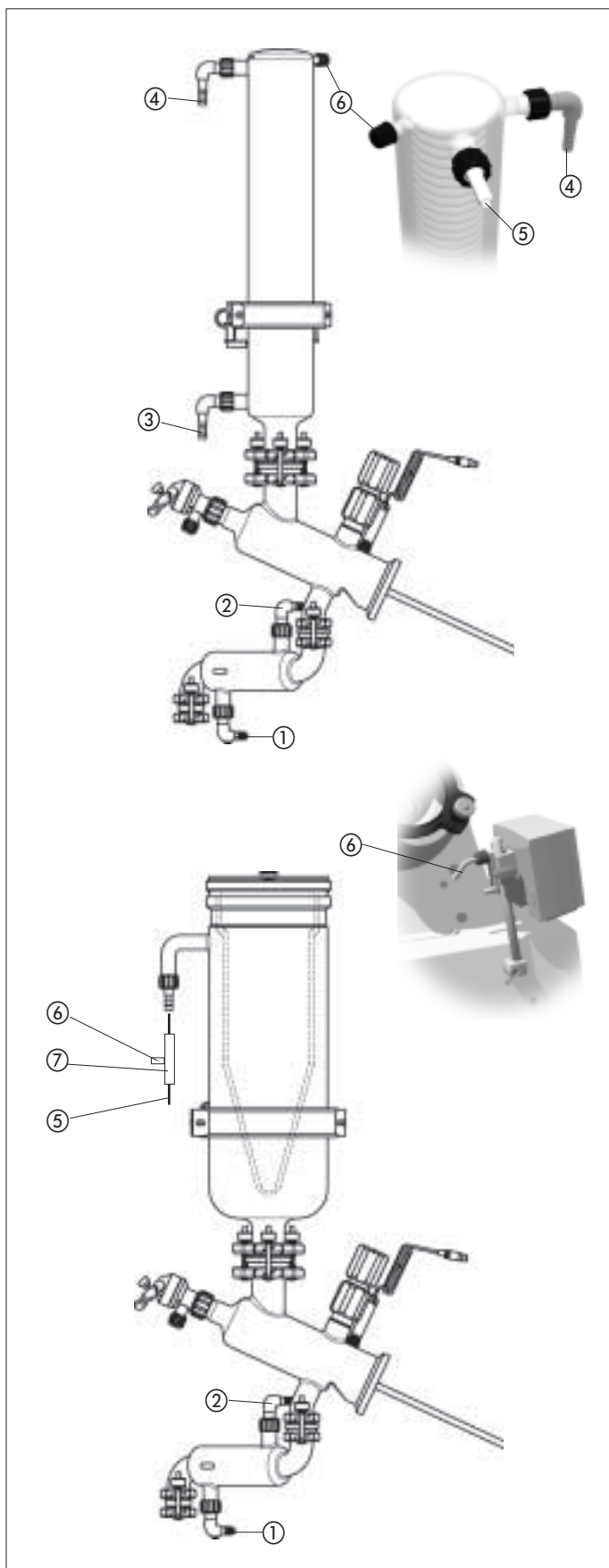

The following is the key for all of the hose diagrams on these two pages.

- ① Cooling water inlet for first condenser
- ② Cooling water outlet for first condenser
- ③ Cooling water inlet for second condenser
- ④ Cooling water outlet for second condenser
- ⑤ Vacuum connection
- ⑥ Vacuum controller
- ⑦ T-piece (026117)

Fig. 18: Hose Couplings 2

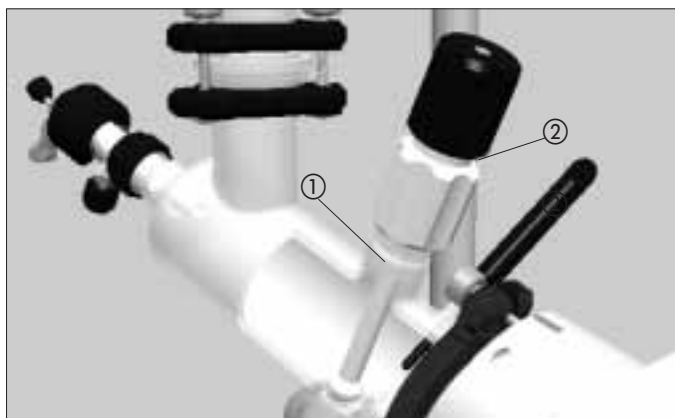

Fig. 19: Shut-off tap

4.12 Operating the Shut-off tap

The shut-off tap is of a special design. It does not have a continuous thread on its inside for tightening it, but rather a sliding plane with two fixed latching positions. The closing pressure when it is in a closed position is provided by a prestressed spring.

- Insert the shut-off tap on the distribution head and turn the white lower section of the grip ① clockwise until the shut-off tap is tightly seated.
- To open:
Turn the gray upper section of the grip ② clockwise until the shut-off tap latches into the 1st position.
If the opening is not large enough, continue turning until the shut-off tap reaches the 2nd position.

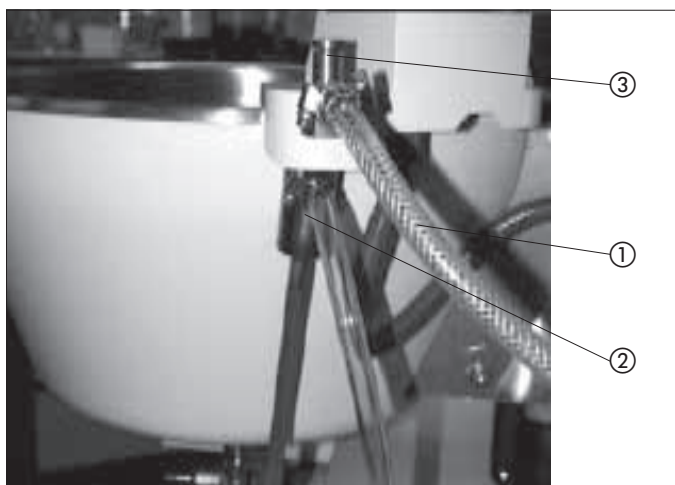

Fig. 20: Bath replenishment

4.13 Bath Replenishment (Optional)

- ① Bath replenishment inlet
Hose nipple, Diam. 14 mm
- ② Bath replenishment outlet
Hose nipple, Diam. 14 mm

Opening the needle valve ③ slightly by one-quarter turn produces a continuous supply flow.

Introduce the Open/Shut valve supplied with the unit into the bath replenishment inlet ① and connect it to "CW Valve" on the back wall of the unit. This interrupts the replenishment of the bath when rotation stops.

The installation of the water valve is described in chapter 8, Replacement Parts, Water Valve.

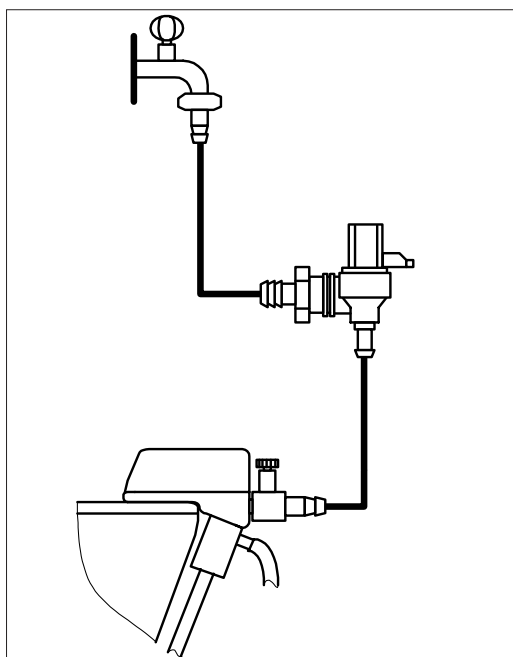

Fig. 21: Bath replenishment

If oil is used as heating medium, the bath replenishment has to be emptied and disconnected from the water inlet. Otherwise, there is a risk of water pouring into the hot oil bath.

Operating Instructions!

When rotation stops, the cooling water and bath replenishment water switch OFF after short delay. As soon as rotation starts, the valve reopens and the water flows once again.



Fig. 22: Reset of the over-temperature protection

4.14 Reset of the over-temperature protection

If the heater heats up over 205°C (e.g. if no heating medium is in the bath), it is cut off by a mechanical overtemperature protection. The overtemperature protection is reset by pushing the button under the heating block.

4.15 Heating Medium



Never operate the heating bath when there is no heating medium in it!

Suitable heating media include:

- Water (some Borax should be added when using deionized water)
- Heat transfer oils suitable for use at temperatures up to 160° C (e.g., Ucon HTF 14, Fluka AG).
- Water-soluble polyethylene glycol (e.g., Polyethylene glycol 600, Fluka AG).



After the oil bath has been standing opened for a prolonged period, condensation water can collect on the bottom. When the bath is used again, it must be heated above 100°C with rotating flask in order to drive the water out.

4.16 Checking Installation

After installation has been completed and before doing the first distillation, check to make sure the installation has been carried out correctly:

- Inspect the glass visually for possible damage.
- Check that all connections (steam, water, vacuum) have been fixed properly in position.
- Check the tightness of the vacuum.

5 Operation

Make certain that the unit has been commissioned properly as described in Chapter 4.

5.1 Arrangement of the Operator Control and Display Elements

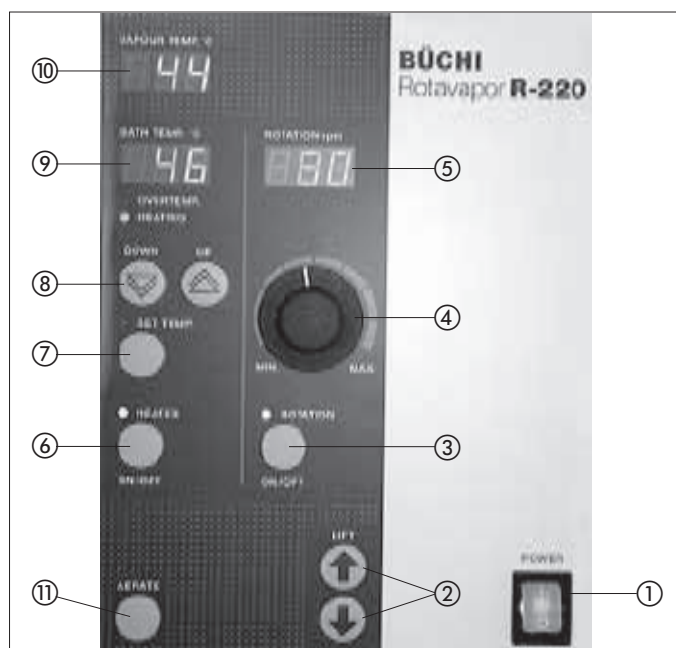

Fig. 23: Operator control elements for the R-220

- ① Main breaker switch
- ② Lift for the bath
- ③ Rotation ON/OFF
- ④ Rotating speed adjustment
- ⑤ Rotating speed display
- ⑥ Heater ON/OFF
- ⑦ Input: Set-point temperature for bath
- ⑧ Temperature UP/DOWN
- ⑨ Display for bath temperature
- ⑩ Display for vapour temperature
- ⑪ Aeration

The bath is lowered automatically when the unit is switched off or in case of a power failure to ensure that the evaporating flask will in all cases remain outside the source of heat (optional).

5.2 Adjusting the Maximum Set-Point Temperature and Automatic Lowering of the Bath in Case of a Power Interruption

Setting the Maximum Set-Point Temperature

- Press the button “SET TEMP” ⑦, simultaneously switching on the main breaker switch ①. This activates the input for setting the maximum set-point temperature.
- The value can be set at any level desired by pressing the “DOWN” and “UP” buttons ⑧.
- The input is stored and the unit switched into the operating mode only after the “AERATE” button ⑪ is then pressed.

Adjusting the Optional Automatic Lowering of the Bath in Case of a Power Interruption

- Press the button “LIFT down” ②, simultaneously switching on the main breaker switch ①.
This results in the display “ON” or “OFF”.
On = The lift lowering has been switched ON
Off = The lift lowering has not been switched ON.
- To switch back and forth between ON and OFF, press repeatedly on the button “LIFT down” ②.
- The input is stored and the unit switched into the operating mode only after the “AERATE” button ⑩ is then pressed repeatedly.

5.3 Tips and Tricks

Selection of the Distillation Temperature

In order to attain optimum distillation conditions, the energy supplied to the distillation from the bath must be dissipated again across the cooler. In order to ensure this, it is best to work according to the following rule of thumb:

Cooling water	ΔT_2	Boiling temperature	ΔT_1	Bath
max. 20 °C		40 °C		60 °C

How do you attain these conditions?

- Set the bath temperature at 60 °C.
- Adjust the cooling water. Its temperature should not be higher than 20 °C.
- Allow the cooling water to flow through the cooler at a rate of about 120–150 liters/hr.
- Select the working vacuum so that the boiling point of the solvent is at 40 °C.
- Obtain the corresponding value for the vacuum from the Table of solvents.

Advantages of a Bath Temperature of 60 °C

- Evaporating flasks can be changed without any danger of scalding.
- The rate of water evaporation out of the heating bath is not yet very high.
- The energy in the heating bath is being utilized very efficiently.

The solvent should condense out in approx. 2/3 to 3/4 of the lengths of the cooling coils present.

5.4 Table of Solvents

Solvent	Formula	Molar Mass in g/mol	Evaporation Energy in J/g	Boiling Point at 1013 mbar	Spec.Gravity in g/cm ³	Vacuum in mbar for a Boiling Point at 40°C
Acetic acid	C ₂ H ₄ O ₂	60.0	695	118	1.049	44
Acetone	C ₃ H ₆ O	58.1	553	56	0.790	556
n-Amyl alcohol, n-Pentanol	C ₅ H ₁₂ O	88.1	595	37	0.814	11
Benzene	C ₆ H ₆	78.1	548	80	0.877	236
n-Butanol, tert. Butanol	C ₄ H ₁₀ O	74.1	620	118	0.810	25
(2-Methyl-2-Propanol)	C ₄ H ₁₀ O	74.1	590	82	0.789	130
Carbon tetrachloride	CCl ₄	153.8	226	77	1.594	271
Chlorobenzene	C ₆ H ₅ Cl	112.6	377	132	1.106	36
Chloroform	CHCl ₃	119.4	264	62	1.483	474
Cyclohexane	C ₆ H ₁₂	84.0	389	81	0.779	235
Diethyl ether	C ₄ H ₁₀ O	74.0	389	35	0.714	850
1,2,-Dichlorethane	C ₂ H ₄ Cl ₂	99.0	335	84	1.235	210
1,2,-Dichlorethylene (cis)	C ₂ H ₂ Cl ₂	97.0	322	60	1.284	479
1,2,-Dichlorethylene (trans)	C ₂ H ₂ Cl ₂	97.0	314	48	1.257	751
Diisopropyl ether	C ₆ H ₁₄ O	102.0	318	68	0.724	375
Dioxane	C ₄ H ₈ O ₂	88.1	406	101	1.034	107
DMF (Dimethylformamide)	C ₃ H ₇ NO	73.1		153	0.949	11
Ethanol	C ₂ H ₆ O	46.0	879	79	0.789	175
Ethyl acetate	C ₄ H ₈ O ₂	88.1	394	77	0.900	240
Heptane	C ₇ H ₁₆	100.2	373	98	0.684	120
Hexane	C ₆ H ₁₄	86.2	368	69	0.660	335
Isoamyl alcohol, 3-Methyl-1-Butanol	C ₅ H ₁₂ O	88.1	595	129	0.809	14
Isopropyl alcohol	C ₃ H ₈ O	60.1	699	82	0.786	137
Methanol	CH ₄ O	32.0	1227	65	0.791	337
Methylene chloride, Dichloromethane	CH ₂ Cl ₂	84.9	373	40	1.327	850
Methylethylketon	C ₄ H ₈ O	72.1	473	80	0.805	243
Pentachlorethane	C ₂ HCl ₅	202.3	201	162	1.680	13
Pentane	C ₅ H ₁₂	72.1	381	36	0.626	850
n-Propyl alcohol	C ₃ H ₈ O	60.1	787	97	0.804	67
1,1,2,2,-Tetrachloroethane	C ₂ H ₂ Cl ₄	167.9	247	146	1.595	35
Tetrachloroethylene	C ₂ Cl ₄	165.8	234	121	1.623	53
THF (Tetrahydrofurane)	C ₄ H ₈ O	72.1		67	0.889	357
Toluol	C ₇ H ₈	92.2	427	111	0.867	77
1,1,1,-Trichlorethane	C ₂ H ₃ Cl ₃	133.4	251	74	1.339	300
Trichlorethylene	C ₂ HCl ₃	131.3	264	87	1.464	183
Water	H ₂ O	18.0	2261	100	1.000	72
Xylol (Mixture)	C ₈ H ₁₀	106.2	389			25
(o)				144	0.880	
(m)				139	0.864	
(p)				138	0.861	

Table 3: Table of Solvents (CRC Handbook, 65th Ed)

6 Maintenance

Please note all rules aimed at keeping the rotary evaporator in a functional condition. These also include periodic cleaning and inspection for any damage that might have occurred.



Make certain that supply of power to the unit has been interrupted before doing any maintenance work on the unit. Always support the bath from below, on the underside of the bath whenever doing any repair work.



Fig. 24: Snap flange coupling, closed

6.1 Taking Apart the Snap Flange Coupling

- Close the two segments of the snap flange coupling.
- Turn the snap flange coupling by 180°, until the closure faces down.
- Have Tool No. 20075 ready at hand.
- Reopen the closure.
- Lift the 1st segment of the snap flange coupling to open it.
- Lift the 2nd segment of the snap flange coupling to open it.
- With three fingers at the tip, reach under the middle segment and raise it up.
- Insert Tool No. 20075 in at the side, between the lugs on the positional lock. Turn lightly until the pin becomes unlatched. Take the snap flange coupling assembly off.
- Clean the snap flange coupling.



Fig. 25: Assembling the snap flange coupling

6.2 Assembling the Snap Flange Coupling

- Insert the snap flange coupling from above, until the pins in the lock latch into the hole on the lug.
- Close the two segments of the snap flange coupling.
- Turn the snap flange coupling again by 180°, until the closure lies at the top.
- Lift the two segments of the snap flange coupling to open them.
- Lay the neck of the glass flask into the middle segment and raise the flask slightly.
- Pull the segment on the left back slightly and close it until the hook latches in place.
- Close the segment on the right.
- Insert the closure hook and close the snap flange coupling with the closure lever. A clear resistance must be felt when doing this. Otherwise no seal can be fully guaranteed.

6.3 Removing the Evaporating Flask Seal

- Seal the holder for the seal by 180°, until the opening faces up.
- Take hold of the seal with both hands, from above and from the front, and pull it out slowly.
- Tilt the seal slightly and carefully pull it all the way out. Be careful not to damage the glass centering bulge when doing so.
- Remove the vapor duct.



Fig. 26: Removing the evaporating flask seal

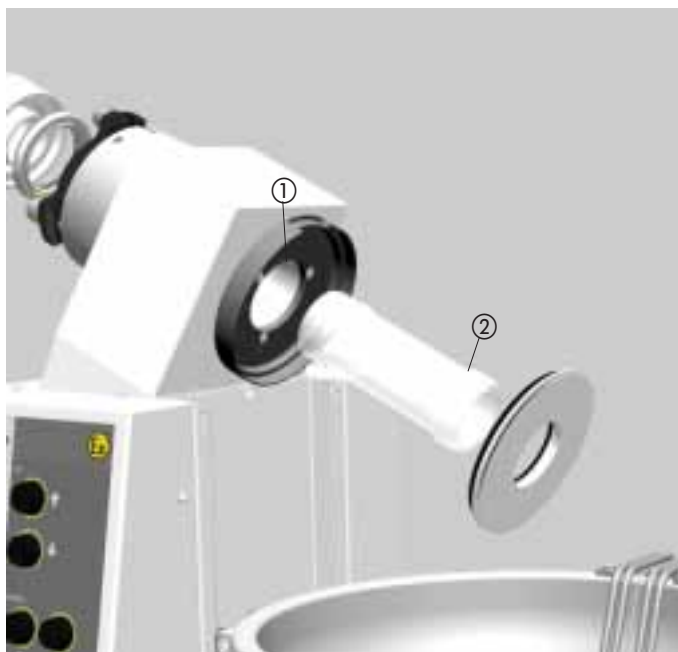

Fig. 27: Inserting the evaporating flask seal 1

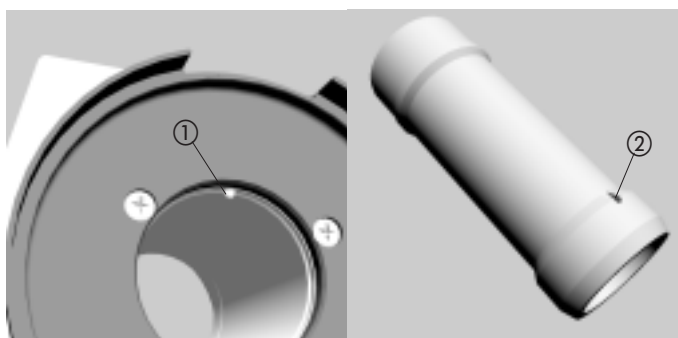

Fig. 28: Inserting the evaporating flask seal 2

6.4 Inserting the Evaporating Flask Seal

- Insert the vapor duct.
- Insert the seal. Using gentle pressure, shove it across the lock preventing it from twisting out of position, and then shove it all the way in. Press it with both thumbs until it latches in position.
- The knob ① in the gearhead must come to rest in the notch ② in the vapour duct.

6.5 Replacement of the Seals for the Distribution Head

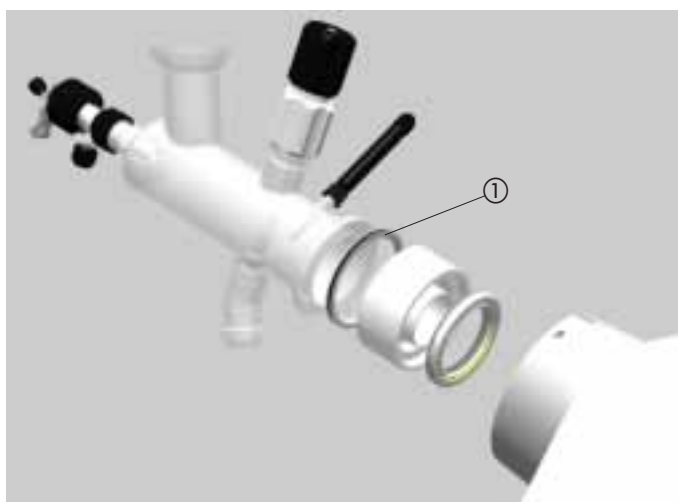

Fig. 29: Replacement of the seals for the distribution head

- Open the DN70 EasyClamp by releasing the knurled nuts on all 3 bolts, but do not screw the nuts completely off.
- Tilt the top bolt out toward the back.
- Open the upper and lower EasyClamp segments and carefully lift the distribution head off the glass assembly.
- Take out the seal ① laid in at the front and replace it.

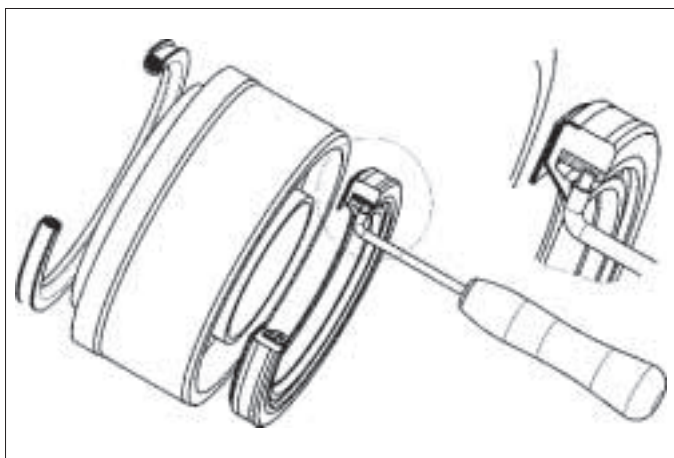

Fig. 30: Replacement of the Vacuum Seal 1



Fig. 31: Replacement of the Vacuum Seal 2



6.6 Replacement of the Vacuum Seal

- Remove the DN70 EasyClamp completely and take off the distribution head.
- Pull the cylindrical seal holder out and turn it over.
- Insert Tool No. 20075 into the metal guide on the seal and pull the seal out.
- Put in the new seal with the dark scraper ring facing the inside and the metal guide ring facing outward.
- Insert the cylinder with the seal at the back lying on the inside.
- Insert the seal at the front.
- Provisionally install the EasyClamp using 2 bolts.
- Set the distribution head of the glass assembly on top of the seal.
- Close the segments of the EasyClamp. Flip the top bolt up and in, and hand-tighten all 3 knurled nuts.

Tip:

When the glass assembly "R" is in place, the vacuum seal can be taken out and/or cleaned without the glass assembly having to be removed.

- Remove the complete DN70 EasyClamp assembly from the distribution head.
- Using a socket wrench, release the fastening for the support rod.
- Carefully turn the glass assembly out around the support rod as an axis.
- Remove the seal.

6.7 Cleaning

Use commercially available cleaning agents to clean the glassware.

Merely wipe the housing off with a damp cloth (without using any organic solvents).

Use a commercially available de-liming agent to dissolve residues of lime in the bath and flush the bath out well.

6.8 Vacuum Seal

The seal should be cleaned whenever necessary, but at least once every six months.

During the intake phase, which lasts approx. 10 hours, the seal will show signs of greater material loss due to wear. This is normal for a PTFE seal.

Cleaning

Before the packet of seals can be removed, the distribution head must be released and screwed off. The complete seal packet can then be taken out and cleaned.

Wipe off the sealing lip using a soft, dry cloth. Clean the running surface on the vapor duct well.



Regular cleaning of the seal will result in a longer service life for it.

6.9 Testing for Leaks

After the rotary evaporator has been completely assembled and before putting it into operation, i.e., while it is clean and dry, check for tightness of the vacuum. To do this, evacuate the unit to below 100 mbar and then close the vacuum line. The rate of pressure rise must not exceed 3 to 5 mbar per 15 minutes.

A greater pressure rise indicates a leak in the vacuum seal. In such a case, recheck all EasyClamp connections and all valves.

6.10 Customer Service

No intervention on or in the unit is permissible except when done by authorized Service personnel. These are individuals with a well-backed technical professional training and knowledge of the dangers that result from a failure to observe the safety precautions required. BÜCHI's Customer Service representatives have available to them a Service Manual specific to the unit in question. That manual is issued only to authorized Service personnel.

The addresses of BÜCHI's official Customer Service representatives are shown on the back cover of this Operation Manual. Please turn to these representatives should you have any malfunctions, technical questions, or problems in using the unit.

BÜCHI's Customer Service Dept. will be ready and happy to offer the following services:

- Spare parts service
- Repair service
- Maintenance service
- Technical consultation.

7 Taking out of Operation



Remove all hazardous materials and clean the unit thoroughly. This prevents any risk that individuals could suffer injuries due to contact with hazardous materials.

7.1 Storage

Always store the unit and spare parts for it in a clean and dry location.

7.2 Packing / Transport

The original packing has been specially designed for transporting the unit and the glass parts for it. Use only the original packing materials for any further transport.

7.3 Waste Disposal

Table 7 in the Appendix, Chapter 9, contains a list of the materials, including their material codes, used for the most important components of the unit. This list has been provided in order to enable environmentally correct disposal of the rotary evaporator. It ensures that the parts can be separated and sent for appropriate recycling. Please refer to the pertinent guidelines when disposing of electrical parts. In addition, observe all regional and local laws covering waste disposal.

Used batteries may be returned directly to your BÜCHI representative for disposal.

8 Spare Parts and Accessories

Only original BÜCHI accessories and spare parts ensure safe operation and a proper functioning of the unit. The use of spare parts and accessories other than those from BÜCHI is permissible only with prior approval of the manufacturer. The Spare Parts Catalog may be used for purposes of assembly and disassembly only in conjunction with the corresponding Chapters 4 and 7 in this Operation Manual. Disclosure and distribution to third parties, and manufacturing based on this manual are strictly forbidden.

Copyright by Büchi AG. All rights reserved.

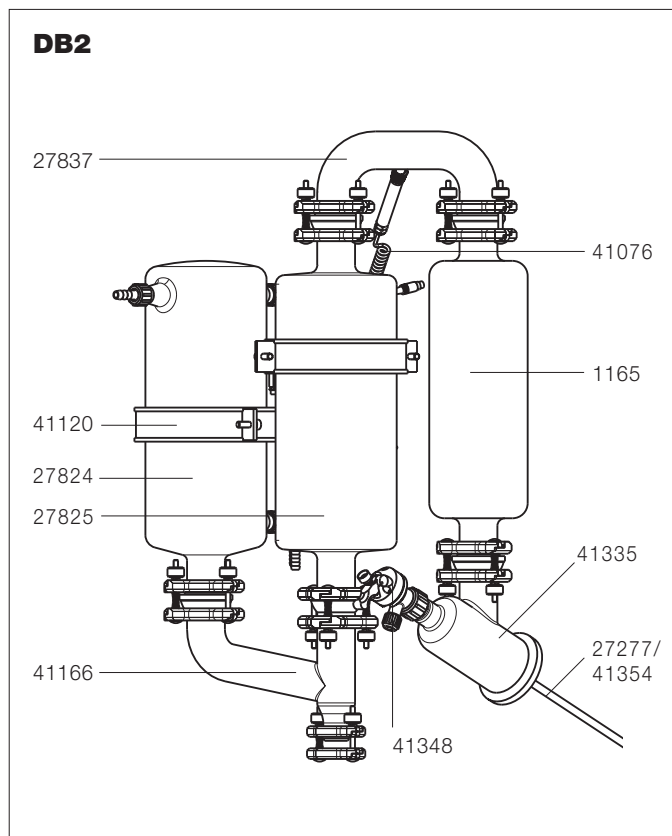
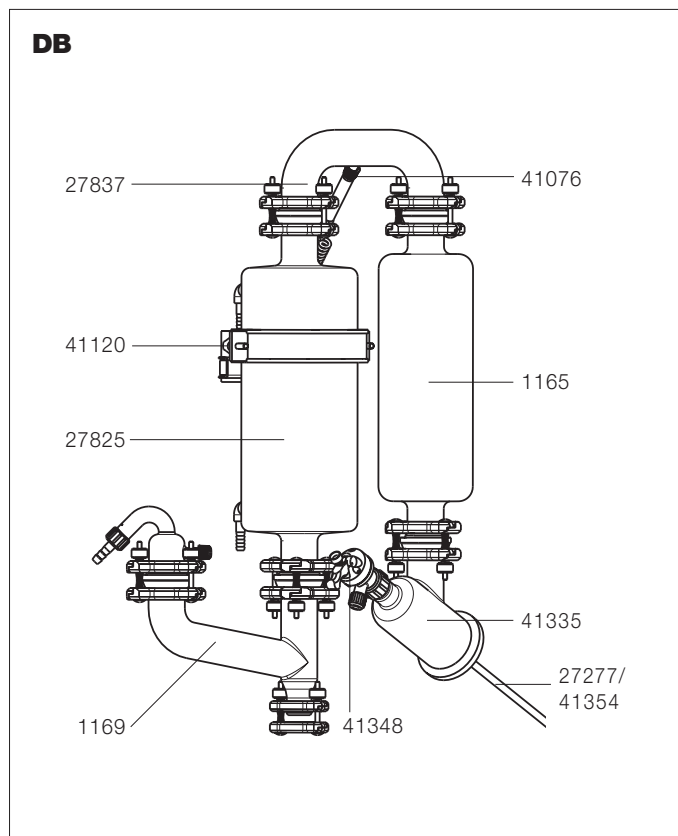
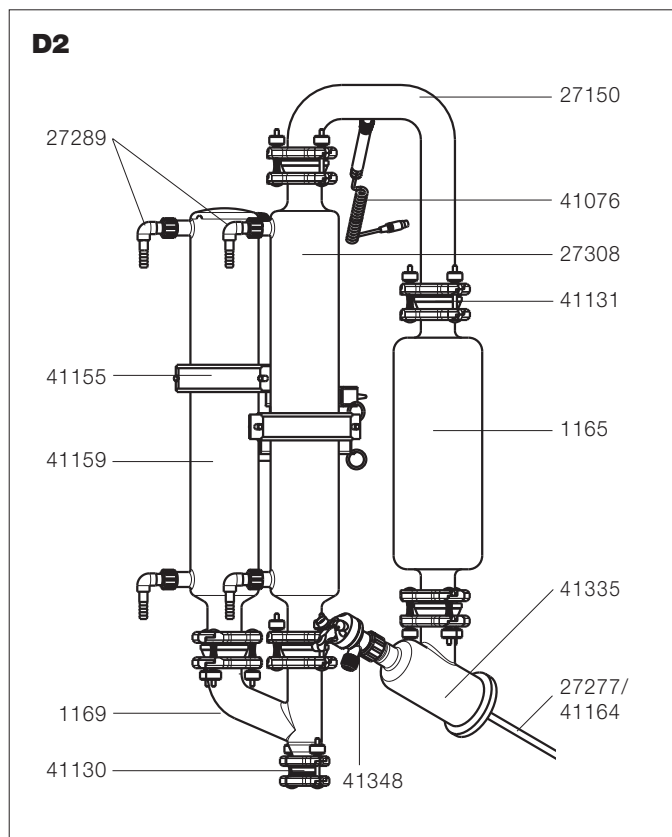
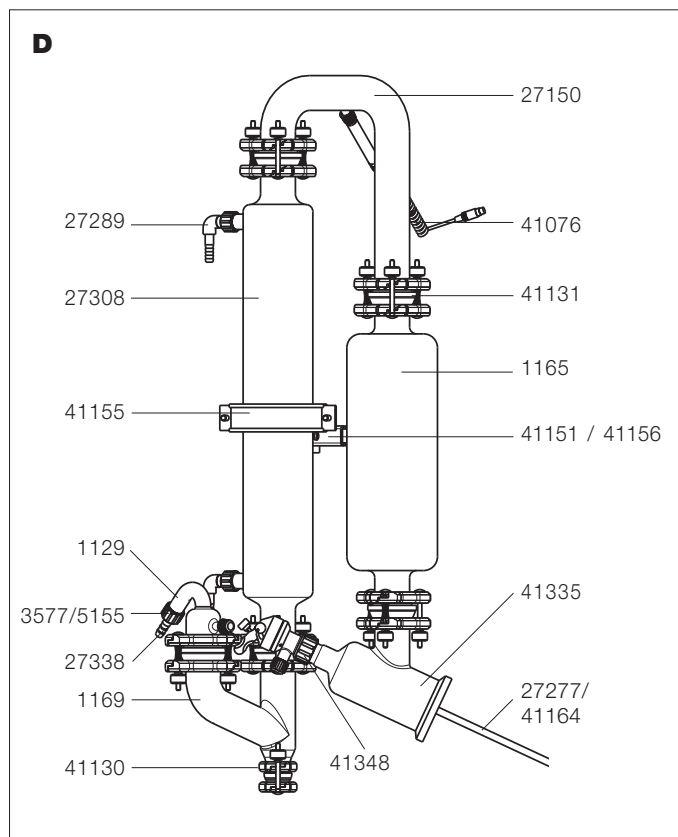
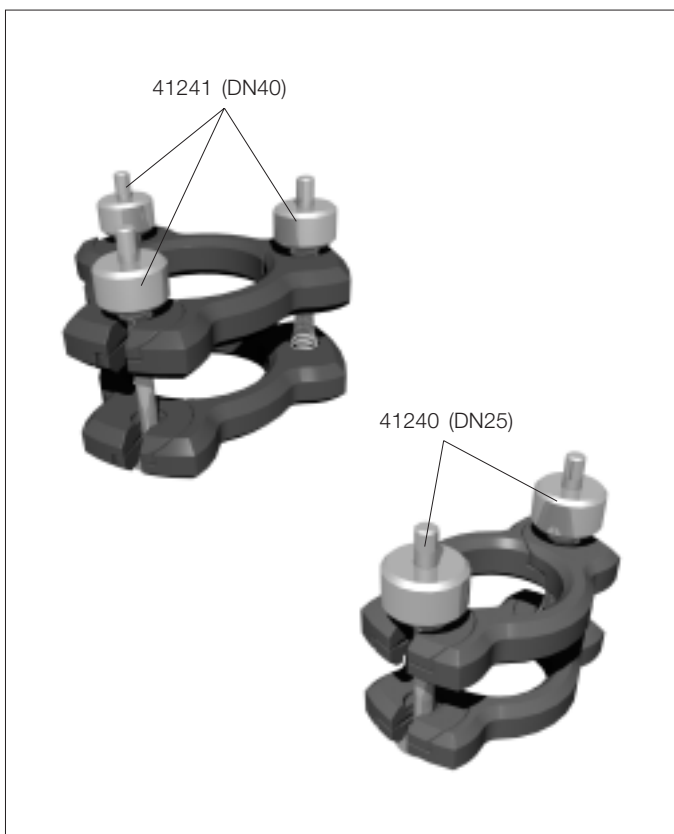
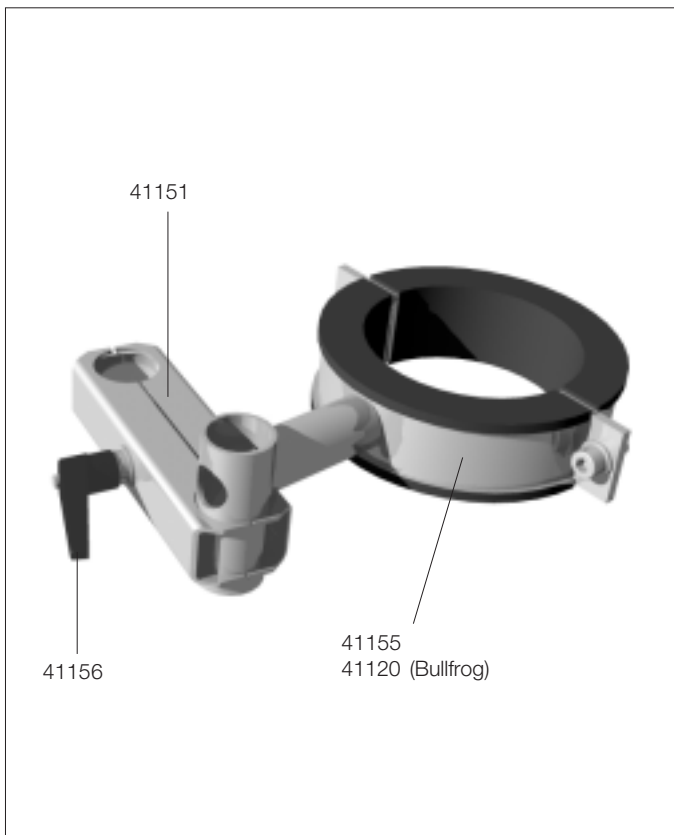

Fig. 32: Spare parts, Glass Assemblies D, D2, DB, DB2



8.1 Spare Parts: Glass Assemblies D, D2, DB, DB2

Component	Ordering No.
Vacuum connector PLG	01129
Expansion vessel PLG	01165
Y-connection PLG	01169
Threaded sleeve Svl 22	03577
Seal Svl 22 Id 17 PTFE	05155
U-tube PLG	27150
PTFE hose, Outer Diam. 10.0x1.0	27277
Screwed fitting Svl 22	27289
Cooler, 3 coil PLG	27308
Hose nipple	27338
Cooler Bullfrog, closed, PLG	27824
Cooler Bullfrog PLG	27825
U-Tube Bullfrog PLG	27837
Temperature sensor B, complete	41076
Glass holder B, complete	41120
EasyClamp, DN25	41130
EasyClamp, DN40	41131
Pivoting clamp, complete	41151
Glass holder, complete	41155
Clamping lever	41156
Cooler, 3-coil, closed PLG	41159
Y-connection Bullfrog PLG	41166
Set of bolts for EasyClamp, DN25	41240
Set of bolts for EasyClamp, DN40	41241
Inlet valve, complete	41348
Connection PTFE	41354
Distribution piece "D" PLG	41335

Table 4: Spare parts, Glass Assemblies D, D2, DB, DB2

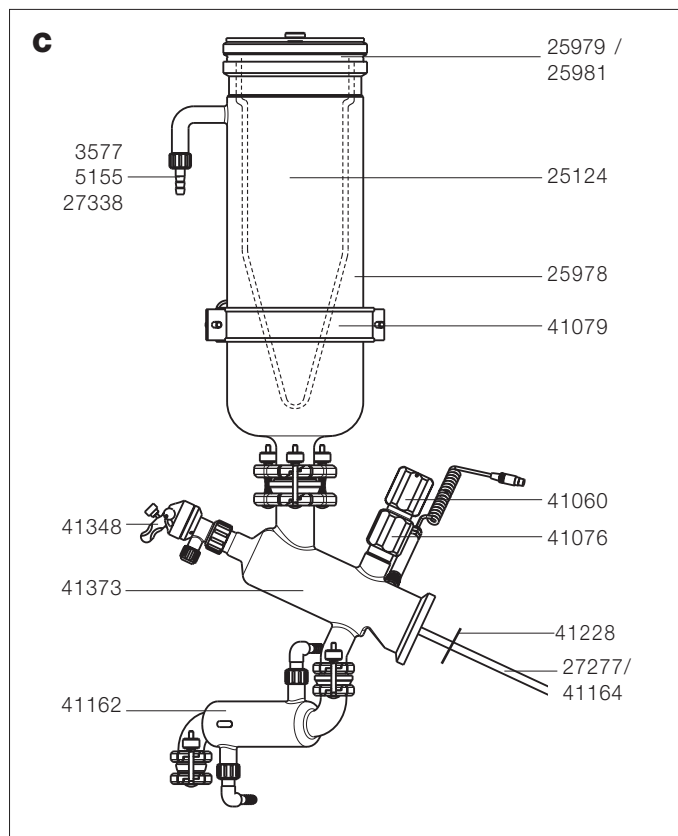
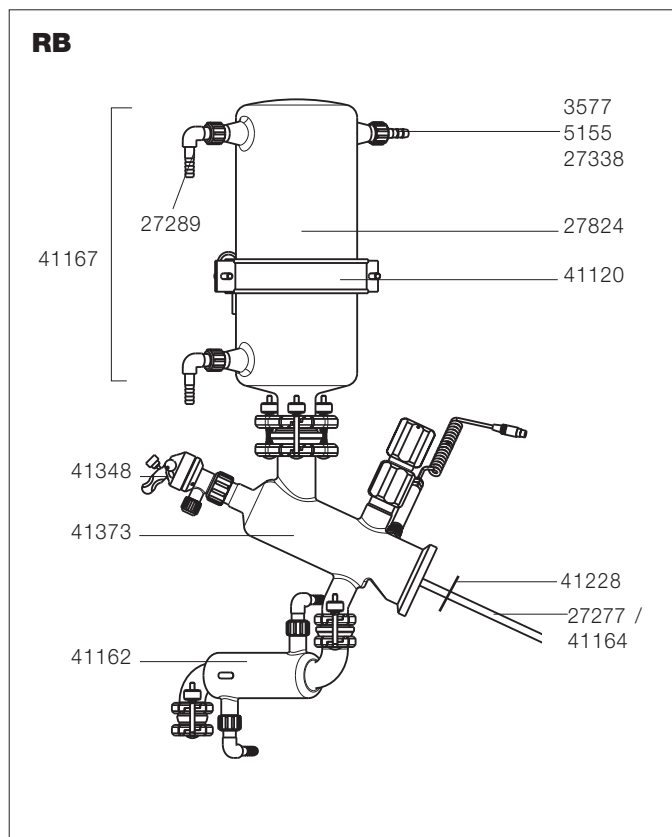
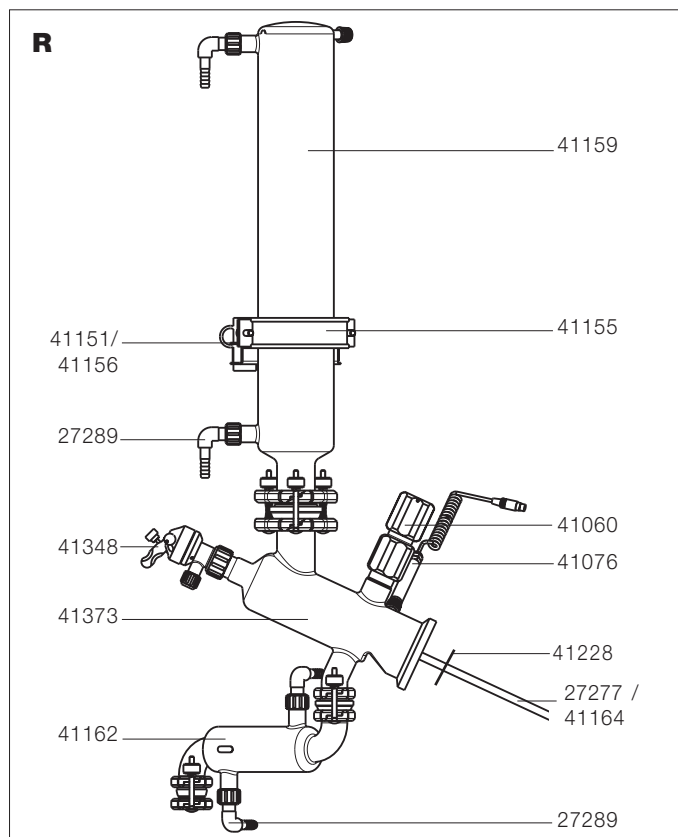
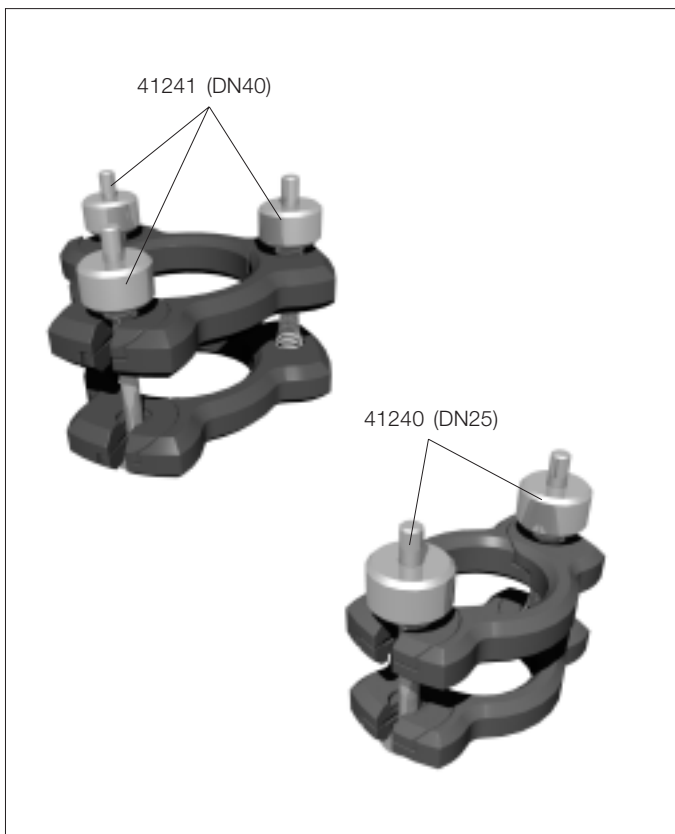
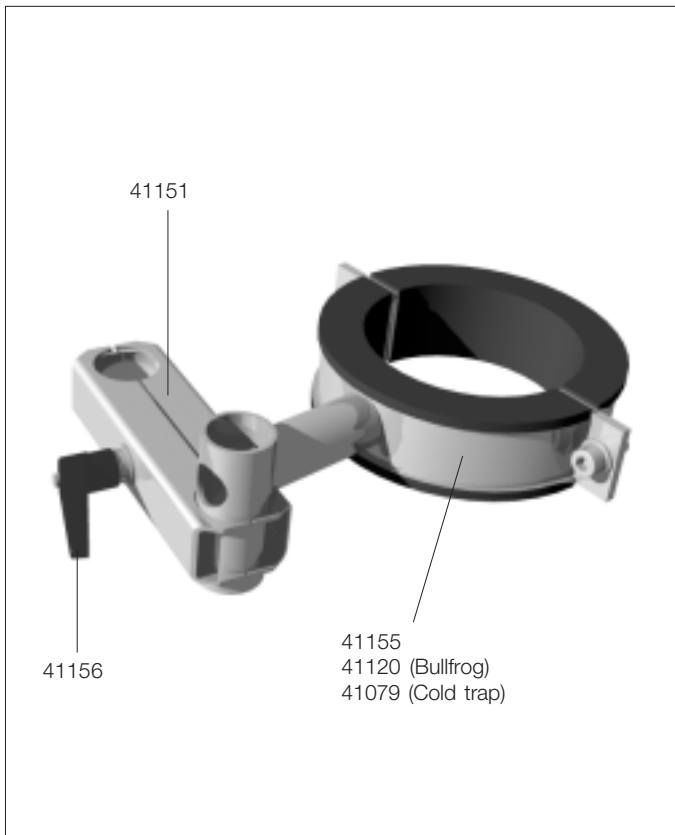

Fig.33: Spare parts, Glass Assemblies R, RB, C



8.2 Spare Parts: Glass Assemblies R, RB, C

Component	Ordering No.
Threaded sleeve Svl 22	03577
Seal Svl 22 Id 17 PTFE	05155
Cold trap	25124
Cold trap, PLG	25978
Cold trap cover	25979
Cover seal	25981
PTFE hose, Outer Diam. 10.0x1.0	27277
Screwed fitting Svl 22	27289
Hose nipple	27338
Cooler Bullfrog, closed, PLG	27824
Shut-off tap, large, complete	41060
Temperature sensor B, complete	41076
Glass holder C, complete	41079
Glass holder B, complete	41120
EasyClamp, DN25	41130
EasyClamp, DN40	41131
Pivoting clamp, complete	41151
Glass holder, complete	41155
Clamping lever	41156
Cooler, 3-coil, closed PLG	41159
Condensate cooler	41162
Cold trap, complete	41167
Set of 10 teflon discs	41228
Set of bolts for EasyClamp, DN25	41240
Set of bolts for EasyClamp, DN40	41241
Inlet valve, complete	41348
Connection, PTFE	41354
Distribution piece "R"	41373

Table 5: Spare parts, Glass Assemblies R, RB, C

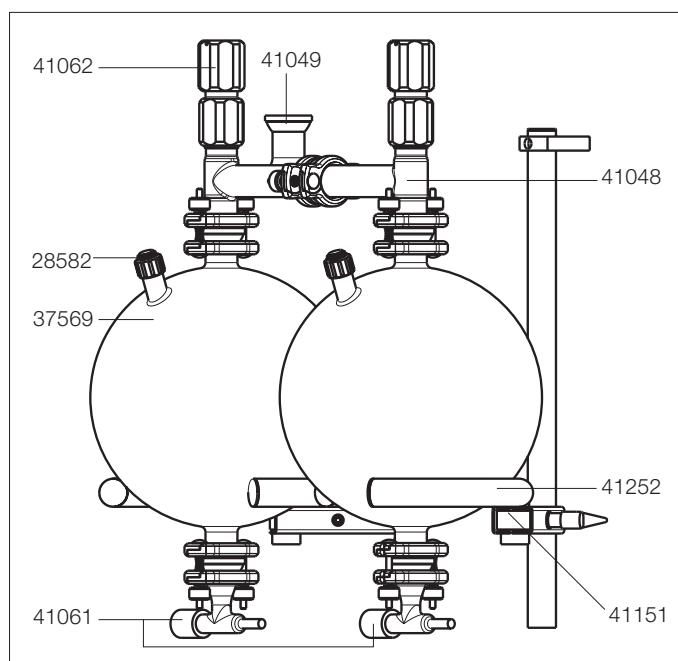

Fig. 34: Interchangeable receiver (W)

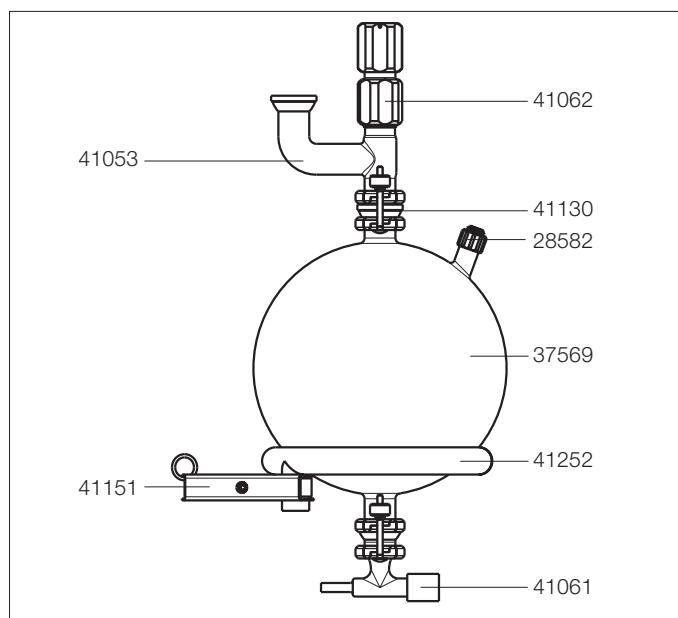

Fig. 35: Single receiver (E)

8.3 Miscellaneous

Component Ordering No.

Interchangeable receiver (W)

Receiving flask 10L	37569
Branching piece 1 PLG	41048
Branching piece 2 PLG	41049
Outlet valve, DN25/2	41061
Shut-off tap, small, complete	41062
EasyClamp, DN25	41130
Pivoting clamp, complete	41151
Base for flask	41252
Ventilation cap	28582

Single receiver (E)

Receiving flask 10L	37569
Branching piece PLG	41053
Outlet valve, DN25/2	41061
Shut-off tap, small, complete	41062
EasyClamp, DN25	41130
Pivoting clamp, complete	41151
Base for flask	41252
Ventilation cap	28582

Hose Connections

Softaflex hose, Inside Diam. 8.0 (3.4 m)	04113
Vacuum hose, Inside Diam. 10.0x5.0 (3.5 m)	04125
Plastic hose, Inside Diam. 10.0x2.0 (4.5 m)	27146
PTFE hose, Outside Diam. 10.0x1.0 (2.0 m)	27277

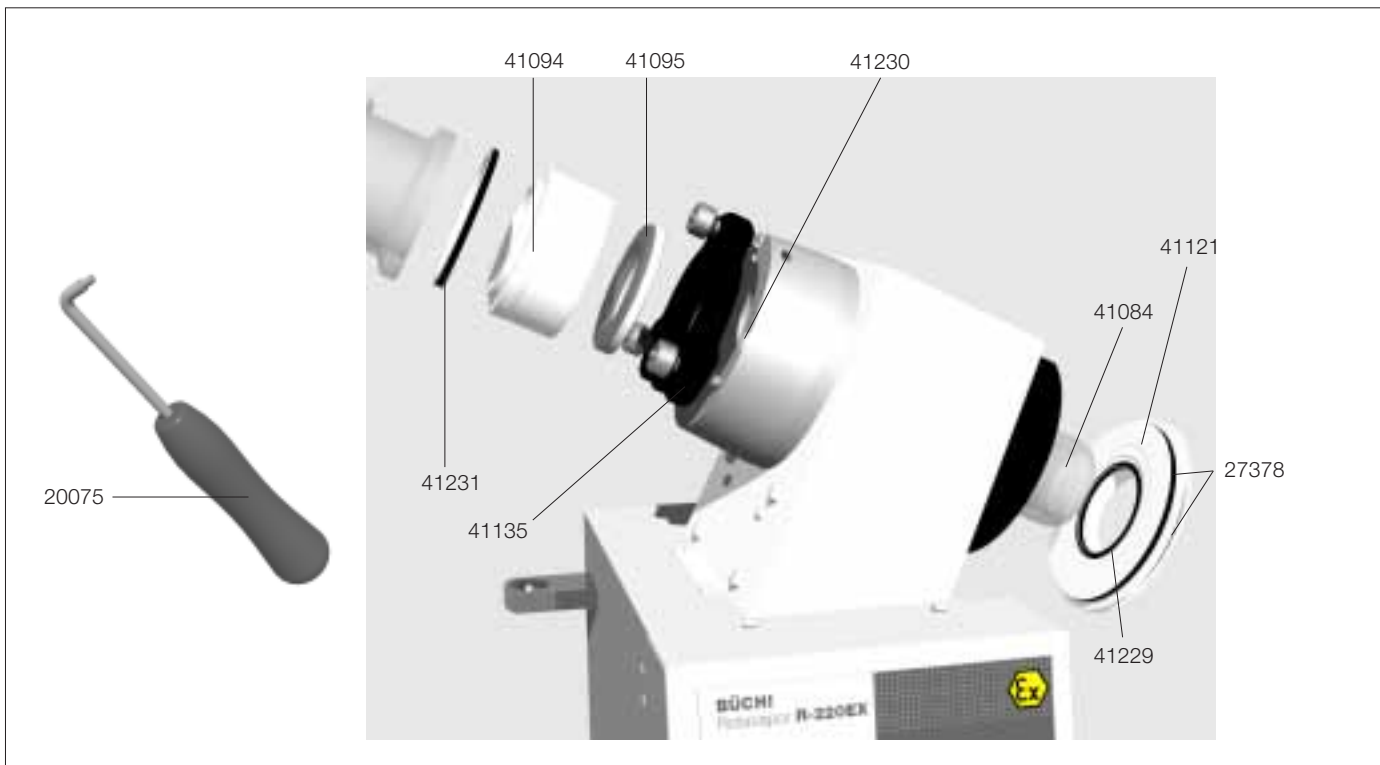

Fig. 36: Sealing elements

Component

Ordering No.

Sealing elements

Support ring inlet valve	41147
Seal SVL 30	00398
Screw Cap SVL 30	03223
Screw Cap SVL 15	03549
Seal tool	20075
O-ring 130x5.0 Fpm70	27378
Vapor duct	41084
Seal holder	41094
Vacuum seal	41095
Evaporating flask seal, complete	41121
Easy Clamp element, DN70	41135
Set of 5 O-rings 64x5.0	41229
Set of 10 cover caps, D11 Pa	41230
Set of distribution head sealings	41231
Glass body	41346
Inlet valve, complete	41348
Connection, PTFE	41354
PTFE bellows	41388
Set of 5 SVL 15 seals	41946

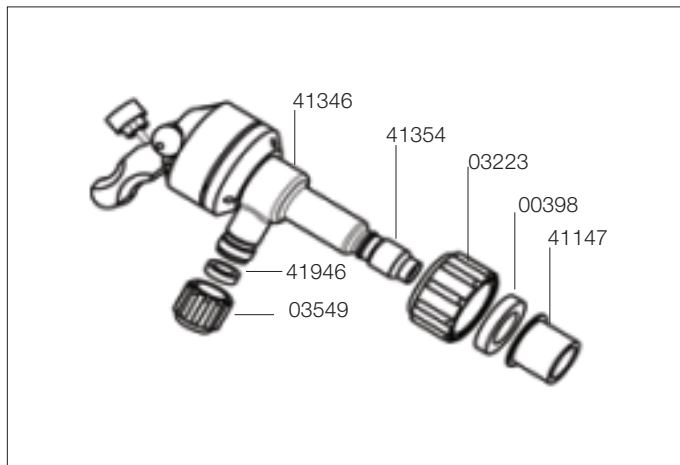

Fig. 37: Inlet valve, complete

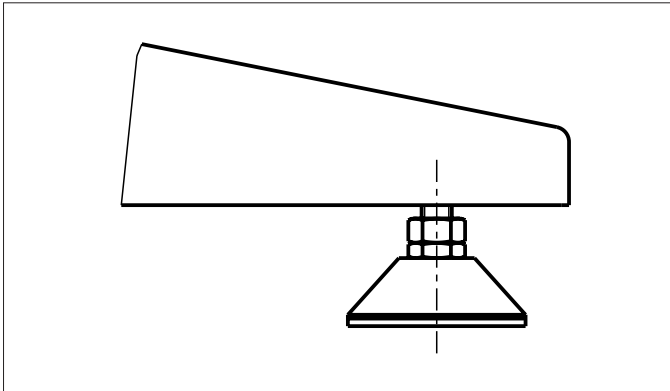

Fig. 38: Machine leg

Component**Ordering No.**

Adjustable machine leg

41018

Fig. 39: Snap flange coupling, complete

Clip

41110

Detent

41111

Snap flange coupling, completel.

41112

Fig. 40: Protective screen

Protective screen

41214

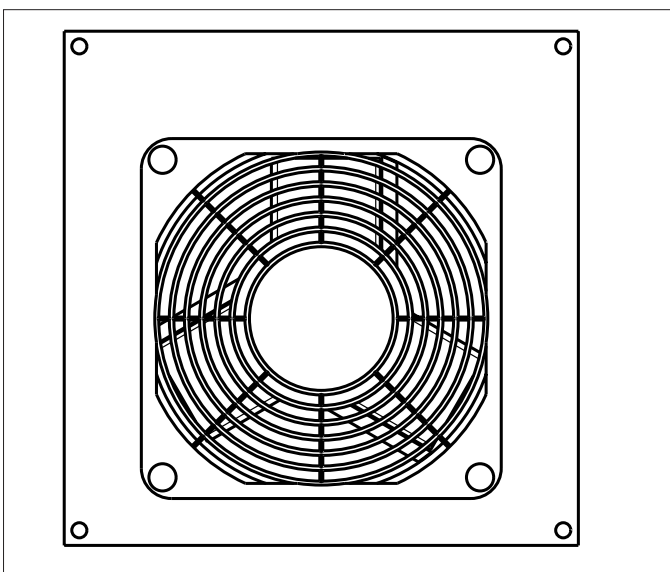

Fig. 41: Lamella curtain

8.4 Accessories

Component	Ordering No.
Lamella curtain	
Lamella curtain	41256
Individual lamella	41267

Installation Instructions!

- 1) Put the lamella curtain ① on the support rod ②.
- 2) Turn the lamella curtain until position is parallel to the edge of the chassis.
- 3) Tighten the screw.



Fig. 42: Foam detector

Foam detector

The foam detection consists of a special distribution piece for the descending glass configuration, the sensor, power supply and the aeration valve. The system will detect the rising foam and aerate the system for a split second.

Foam detector	40507
---------------	--------------

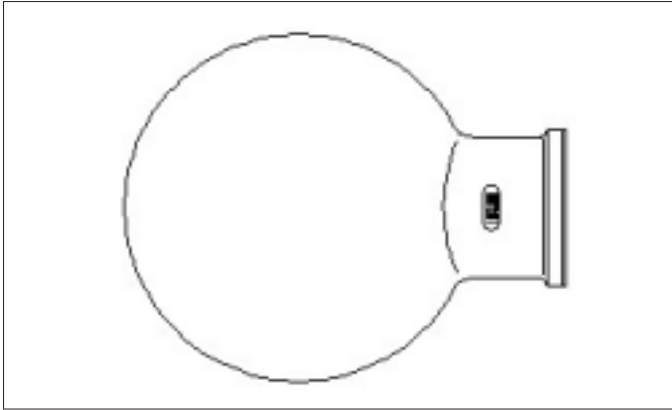

Fig. 43: Evaporating flask

Component**Ordering No.**

6 L Evaporating flask	27470
10 L Evaporating flask	27469
20 L Evaporating flask	27468

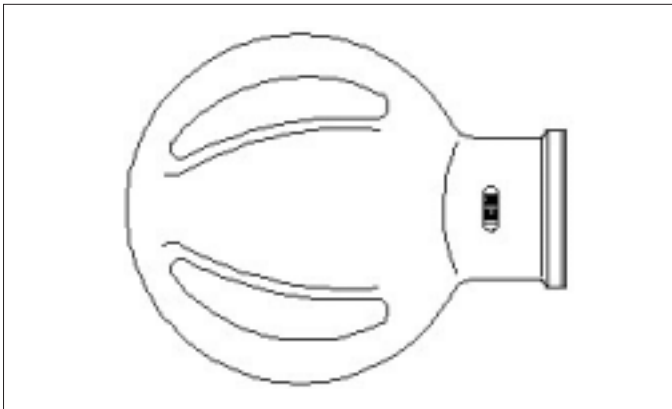

Fig. 44: Drying flask

This special flask is particularly suited for drying powdery substances or a homogeneous mixture of solid products. The baffles attached on the circumference of the flask ensure an intensive circulation of the contents inside the flask.

10 L Drying flask	28592
20 L Drying flask	28593

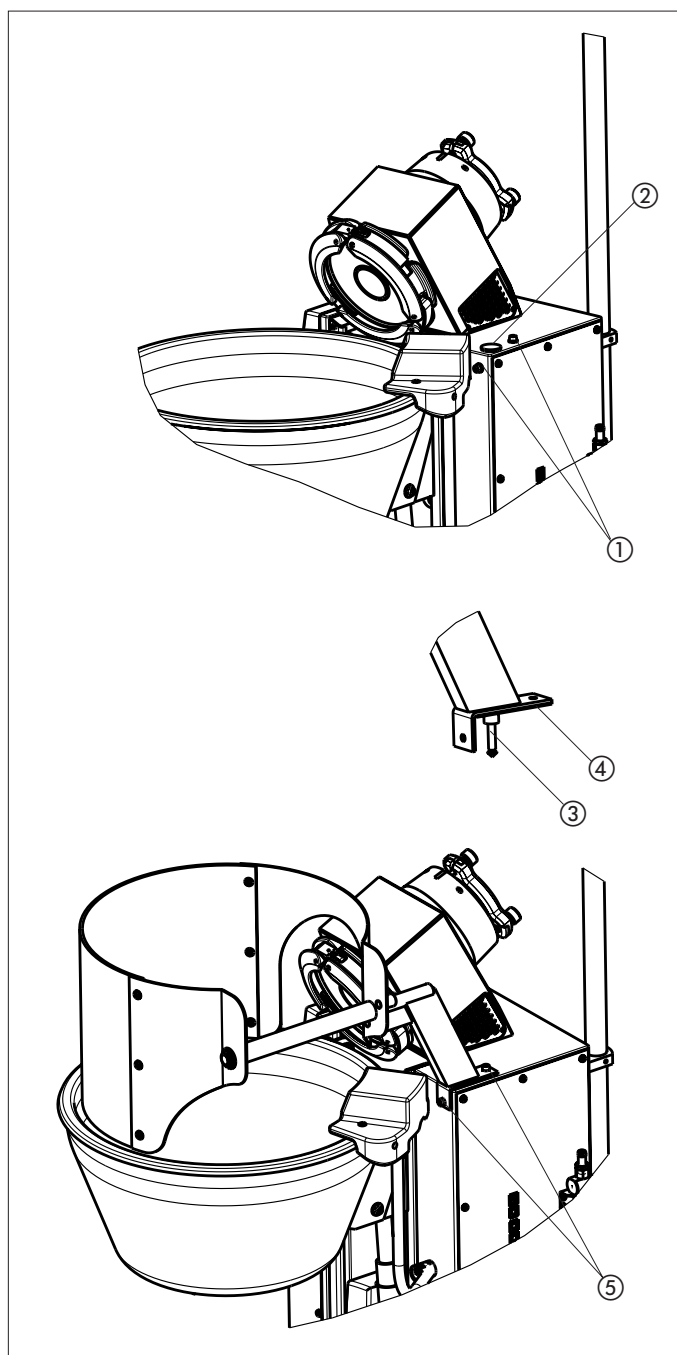

Fig. 45: Splash Protection

Component**Ordering No.****Splash Protection**

Splash Protection	41201
Protective shield	41204
Protective shield seal	41259

Installation Instructions!

- 1) Switch the unit OFF.
- 2) Remove the two bolts ① and the plastic cover ②.
- 3) Put on the seal ④.
- 4) Plug in the plug ③.
- 5) Fasten the splash protection in place with the bolts ⑤.
- 6) Switch the unit ON.

Operating Instructions!

Opening the splash protection switches the rotation OFF. When the splash protection is closed again, the flask starts to rotate once more when the rotation button is pressed.

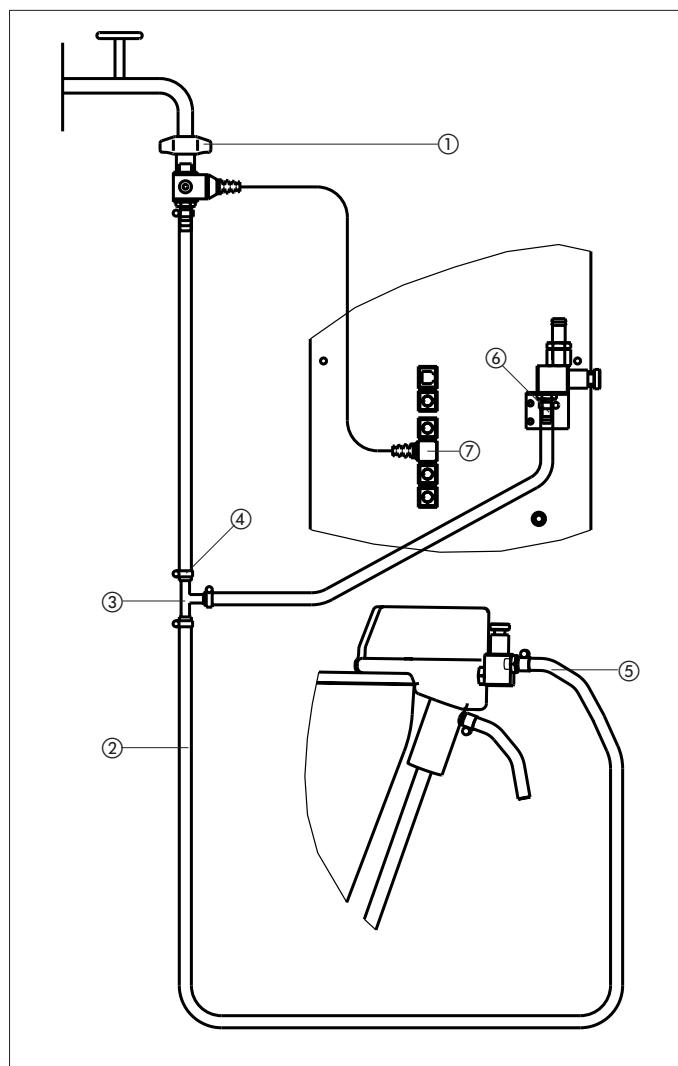

Fig. 46: Water valve

Component**Ordering No.****Water Valve**

Water valve cpl.

41 191

T-piece

26835**Installation Instructions!**

- 1) Switch the unit OFF.
- 2) Connect the water valve ① to the water cock.

With optional bath replenishment

- 3) Connect the water hose ② to the tee ③ and secure them with pivoting clamps ④.
 - 4) Connect the end of the water hose ⑤ to the control valve for bath replenishment and secure it with pivoting clamps.
-
- 5) Connect the end of the hose ⑥ at "CW-in" on the R-220 and secure it with pivoting clamps.
 - 6) Connect the valve plug ⑦ on the R-220 at the CW-Valve.
 - 7) Switch the unit ON.

Operating Instructions!

When rotation stops, the cooling water and bath replenishment water switch OFF after short delay. As soon as rotation starts, the valve reopens and the water flows once again.

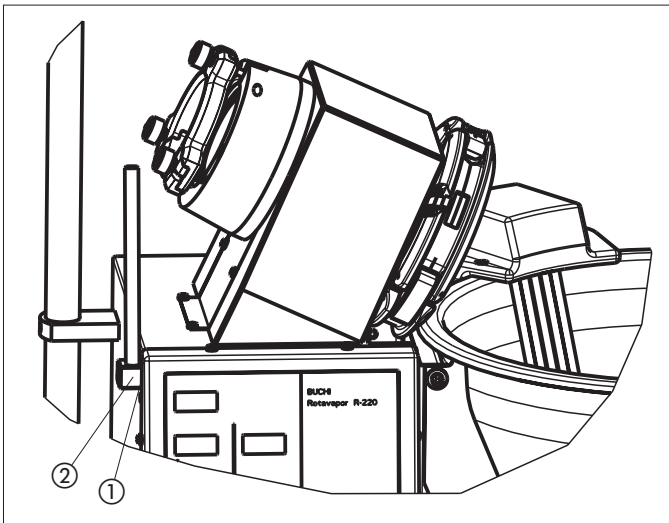

Fig. 47: Support for the controller

Component

Ordering No.

Support for Controller

Support for controller, complete	41223
----------------------------------	--------------

Installation Instructions!

- 1) Remove the cover ①.
- 2) Fasten the support using the bolt supplied with the unit ②.

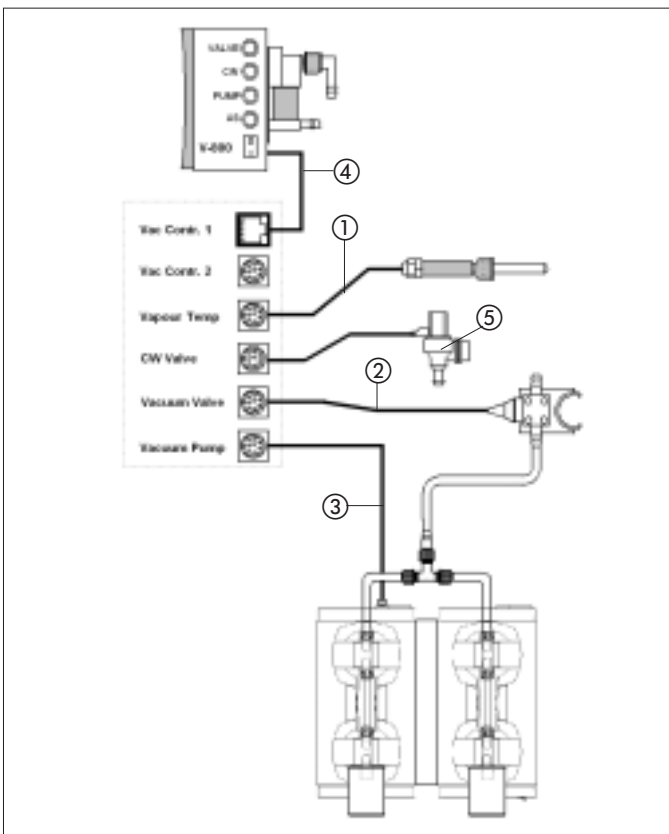

Fig. 48: Connections to R-220

Vacuum Controller V-800 for R-220

Vacuum Controller V-800, 230 V	40721
Vacuum Controller V-800, 120 V	40722
Vacuum Controller V-805, 230 V	40723
Vacuum Controller V-805, 120 V	40724

Connections

① Temperature probe	41076
② Vacuum valve	31354
③ Control cable V-1000	38010
④ Control cable V-800/V-805	40758
⑤ Coolingwater valve	41191

9 Appendix

9.1 Technical Data

R-220

Power Connection	4.2 kW
Connection Voltage	200 VAC / 230 VAC / 400 VAC \pm 10 %
Evaporator output	Up to 4 l/h water, higher for other solvents (depending on the heat of evaporation)
Frequency	50 - 60 Hz
Site condition	for indoor use only, altitude up to 2000 m. maximum relativ humidity 80% for temperatures up to 30°C decreasin linearly to 50% relative humidity at 40°C
Ambient temperature	5-40°C
Rotary drive	Induction motor with external fan, 180 W
Speed control	Electronic, continuous, 5 to 140 RPM
Bath output	3600 W, Heat introduction 3W/cm ²
Bath dimensions	Diam. 430 mm x 240 mm, Bath capacity 20 l, without flask immersed
Bath pan	Stainless steel X2CrNiMo 17 13 2 (1.4404 or 316L)
Bath heater control	Electronic, with PT-1000, Control accuracy \pm 2°C
Range of bath temperatures	20°C – 180°C
Overheating protection	Separate monitoring circuit. Responds at 15°C over set-point temperature
Bath lift	Linear drive, Safety Class IP 65
Battery	Battery, PB 12V
Measurement of vapor temperature	PT-1000
Displays	Vapor temperature, bath temperature, rotary speed
Aeration	Integrated valve, aerated in case of power failure or by button, with inert gas connection
Installation category	II
degree of pollution	2
Vacuum pump	Recommended suction output 2 – 4 m ³ /h
Cooling water consumption	120 – 200 l/h, with needle valve control
Cooling water pressure	max. 1.7 bar abs., without any pulsation
Weight	65 kg, without glass
Dimensions	Refer to pertinent chapter

Table 6: Technical Data

9.2 Materials Used

Part	Material	
	Description	Code
Chassis	X5CrNi 18 10	1,4301 or 304
Bath pan	X2CrNiMo 17 13 2	1,4404 or 316L
Glass	Borosilicate 3,3	
Seals	Polytetrafluorethylene	PTFE
Taps	Polytetrafluorethylene	PTFE

Table 7: Materials Used

9.3 Error Messages

Error messages indicate a defect on the unit and are signalled on the bath temperature display. They appear with an “E” at the start, followed by a specific number:

E0 :	Message:	Output from the bath sensor not within the valid range.
	Cause:	Sensor defective or a short-circuit has occurred.
	Action:	The bath heater is switched OFF. The bath is lowered. Rotation stops.
	Acknowledgment:	Switch the unit OFF.
E2 :	Message:	The bath is not reaching the intended maximum height.
	Cause:	The motor is defective or blocked. No voltage.
	Action:	The lift motor switches OFF. Rotation and heating continue.
	Acknowledgment:	Switch the unit OFF.
E3 :	Message:	The rotary drive does not reaching the required speed, or is turning too quickly.
	Cause:	Drive defective. Mechanical blocking. No power. Semi-conductor relay defective.
	Action:	Bath heater is switched OFF. Bath is lowered.
	Acknowledgment:	Switch the unit OFF.
E4 :	Message:	Battery voltage too low. Displayed only when starting the unit.
	Cause:	PB battery defective
	Action:	None
	Acknowledgment:	Press the “Aerate” button.
E5 :	Message:	EEPROM error.
	Cause:	Hardware defect.
	Action:	None.
	Acknowledgment:	Press the “Aerate” button. Work can then be continued, but a Service technician must be notified of the problem.
E6 :	Message:	Overload of the valve output
	Cause:	Valve defective or wrong connections
	Action:	None.
	Acknowledgment:	Switch the unit OFF

Table 8: Error messages



To let all possible error messages appear, the device must be shut off and on at least once per 24 h.

9.4 FCC requirements (for USA and Canada)

English:

This equipment has been tested and found to comply with the limits for a Class A digital device, pursuant to both Part 15 of the FCC Rules and the radio interference regulations of the Canadian Department of Communications. These limits are designed to provide reasonable protection against harmful interference when the equipment is operated in a commercial environment.

This equipment generates, uses and can radiate radio frequency energy and, if not installed and used in accordance with the instruction manual, may cause harmful interference to radio communications. Operation of this equipment in a residential area is likely to cause harmful interference in which case the user will be required to correct the interference at his own expense.

Français:

Cet appareil a été testé et s'est avéré conforme aux limites prévues pour les appareils numériques de classe A et à la partie 15 de la réglementation FCC et à la réglementation des radio-interférences du Canadian Department of Communications. Ces limites sont destinées à fournir une protection adéquate contre les interférences néfastes lorsque l'appareil est utilisé dans un environnement commercial.

Cet appareil génère, utilise et peut radier une énergie à fréquence radioélectrique, il est en outre susceptible d'engendrer des interférences avec les communications radio, s'il n'est pas installé et utilisé conformément aux instructions du mode d'emploi. L'utilisation de cet appareil dans les zones résidentielles peut causer des interférences néfastes, auquel cas l'exploitant sera amené à prendre les dispositions utiles pour pallier aux interférences à ses propres frais.

9.5 Declaration of Conformity

We

BÜCHI Labortechnik AG
P.O.Box, CH-9230 Flawil, Switzerland

declare on our own responsibility that the product:

BÜCHI Rotavapor **R-220**

to which this declaration refers conforms to the following standards:

EN 61010-1:1993 (~ IEC 1010-1, VDE 0411-1)
Safety Rules for Electrical Measurement, Control, and Laboratory Equipment: General Requirements

EN 61326-1:1997
Electrical Equipment for Measurement, Control and Laboratory Use. EMC Requirements

EN 61000-3-2: 1995/1996
Limits for harmonic current emissions
EN 61000-3-3: 1995
Limitation of voltage fluctuations and flicker

In accordance with the provisions of the EU Guidelines:
73/23/EWG (Guidelines for low voltage electrical equipment)
89/336/EWG (Electromagnetic compatibility)

Flawil, 02.08.2005

BÜCHI Labortechnik AG
Meierseggstrasse 40
9230 Flawil
Schweiz

Tel +41 (0)71 394 63 63
Fax +41 (0)71 394 65 65
buchi@buchi.com
www.buchi.com



Guido Worch
Qualitymanager



