

# **Agilent 7683B Automatic Liquid Sampler**

**Installation, Operation and  
Maintenance**



**Agilent Technologies**

# Notices

© Agilent Technologies, Inc. 2004

No part of this manual may be reproduced in any form or by any means (including electronic storage and retrieval or translation into a foreign language) without prior agreement and written consent from Agilent Technologies, Inc. as governed by United States and international copyright laws.

## Manual Part Number

G2912-90230

## Edition

First edition, August 2004

Printed in USA

Agilent Technologies, Inc.  
2850 Centerville Road  
Wilmington, DE 19808-1610 USA

## Acknowledgements

Teflon<sup>®</sup> is a registered trademark of E.I. DuPont de Nemours Co. Inc.

Target<sup>®</sup> and DP<sup>®</sup> are registered trademarks of National Scientific Co.

## Safety Notices

### CAUTION

A **CAUTION** notice denotes a hazard. It calls attention to an operating procedure, practice, or the like that, if not correctly performed or adhered to, could result in damage to the product or loss of important data. Do not proceed beyond a **CAUTION** notice until the indicated conditions are fully understood and met.

---

### WARNING

A **WARNING** notice denotes a hazard. It calls attention to an operating procedure, practice, or the like that, if not correctly performed or adhered to, could result in personal injury or death. Do not proceed beyond a **WARNING** notice until the indicated conditions are fully understood and met.

---

# Contents

## Safety and Regulatory Information

Important Safety Warnings	12
Many internal parts of the instrument carry dangerous voltages	12
Electrostatic discharge is a threat to instrument electronics	12
Safety and Regulatory Certifications	13
Information	13
Symbols	14
Technical and environmental specifications	14
Electromagnetic compatibility	15
Sound Emission Certification for Federal Republic of Germany	15
Fuses and Battery	16
Cleaning	16
Recycling the Product	16

## Part 1: Installation

### 1 Introduction to Installation

Compatibility	20
Hardware	20
Firmware	20
Overview	22
The controller	22

The injector	22
The tray	22
The Bar Code Reader	22
Hardware Identification	23
5890A GCs that have been fully upgraded to Series II	23
5890 Series II GC	23
6890A, 6890 Plus, and 6890N GCs	24
6850A and 6850 Series II GCs	24
G2614A and G2916A trays	24
Injectors	24
Injector mounting posts	24

## 2 Installation

The Installation Process	26
5890A, fully upgraded to Series II, and 5890 Series II GCs	26
6890A GC	27
6890 Plus GC	27
6890N GC	28
6850 GC	28
Procedure 1. Installing the G2916-61000 Injector Bracket	29
Before you start	29
Install the new injector bracket	31
Check your work	34
Procedure 2. Installing the G2916A Tray	35
5890 Series II GC	35
6890 GC	38
Procedure 3. Installing the Injectors	42
Installing the injector on the GC	42
Check your work	45
Choosing the turret type	45

Procedure 4. Connecting Cables	46
5890 Series II GC	46
6890A GC	47
6890 Plus and 6890N GCs	48
6850 GC	49
Testing the connections	49
Procedure 5. Installing the G2911AA Software on the PC	50
Procedure 6. Installing the G2614A Tray	51
Procedure 7. Installing the G2615A Bar Code Reader	53
Procedure 8. Install the G2912A ALS Controller	55
Temperature and humidity ranges	55
Ventilation requirements	55
Benchtop space requirements	56
Dimensions	56
Orientation	57
Electrical requirements	57
Verifying G2912A ALS Controller power configuration	59
Procedure 9. Replacing the Inlet Chassis Cover (6890A)	60
Procedure 10. Installing a G2612A Controller Board (6890 Plus)	61
Procedure 11. Configuring Your GC and Data System	65
GC	65
Data system	65
Procedure 12. Updating the Firmware	66
All GC and ALS systems	66
6890A, 6890 Plus and 5890 Series II GCs	67
Other ways to check firmware revisions	67
Making A Trial Run	68

## Part 2: Operation

### 3 Introduction to Operation

About your 7683B Automatic Liquid Sampler	74
Capabilities	76
Fast Injection	77
Sample Carryover	79

### 4 Controlling the Sampler

Methods and Sequences	82
The Sampler Cycle	83
Setting Parameters on a 5890 Series II GC	85
Setting Injector Parameters on a 6890 GC	87
Configuring the injector on a 6890 GC	89
Setting sample tray setpoints on a 6890 GC	91
Storing injector setpoints	93
Setting Parameters on a 6850 Series GC	94
To set injection parameters	94
To configure the injector	96

### 5 Syringes and Needles

Syringes	100
Selecting syringes	100
Inspecting a syringe	102
Installing a Syringe	103
Removing a Syringe	106
Replacing Syringe Needles	107

## 6 Vials and Bottles

Preparing Sample Vials	110
Selecting sample vials	110
Selecting vial septa	111
Labeling sample vials	112
Filling sample vials	112
Capping sample vials	113
Preparing Solvent and Waste Bottles	116
Selecting the bottles	116
Filling the solvent bottles	117
Preparing the waste bottles	117
Placing Vials and Bottles in the Sampler	118
Using Two Injectors (5890, 6890 only)	121
How Many Sample Vials Can I Run?	122
Solvent bottle equation (G2913 A injector)	123
Waste bottle equation	123
Example	124
Reduced solvent and sample usage	127

## 7 Running Samples

Running a Sample	130
Using the ALS Controller	131
Interrupting A Run Or Sequence	132
Sampler response to interruptions	132
Restarting an interrupted sequence	132
Running a Priority Sample	134

## Part 3: Maintenance and Troubleshooting

### 8 Maintenance

- Periodic Maintenance 138
- Adapting For Cool On-Column Injection 139
- Installing a Syringe 141
- Removing a Syringe 144
- Replacing Syringe Needles 145
- Changing the Turret 147
- Align Mode 150
- Replacing the Needle Support Assembly on the G2913A  
Injector 153
- Replacing the Needle Guide in the Needle Support Foot 157
- Replacing Power Fuses in the G2912A ALS Controller 158

### 9 Faults and Errors

- Faults 160
- Error Messages 162

### 10 Troubleshooting

- Symptom: Variability 168
- Symptom: Contamination or Ghost Peaks 170
- Symptom: Smaller or Larger Peaks Than Expected 171
- Symptom: Sample Carryover 173
- Symptom: No Signal/No Peaks 174
- Correcting Syringe Problems 175
- Correcting Sample Vial Delivery Problems 176



## 11 Special Topics

- Controlling Sample Vial Temperatures 178
  - Connect the tray quadrants 178
  - Coolant 179
  - Determine the water bath temperature 179
  - Tray quadrant temperatures and pressures 181
  - Water bath and pump specifications 181
- Cool On-Column Injection 183
- Suggestions for Packed Inlets with 530- $\mu$ m Columns 184

## 12 Replacement Parts

- G2912A — 7683B ALS Controller for 5890 Series II and 6890A GCs 186
- G2913A — 7683B Injector Module 188
- G2614A — 7683 ALS Tray 190
- G2916A — 7683 ALS Tray for 5890 Series II GCs 191
- Miscellaneous Parts 192

### A Cables and Connectors

- G2916A/G2614A Trays 194
- G2612A — ALS Controller 197
- G2912-60507 — Remote Start/Stop Cable for 5890 Series II GCs 199
- G1530-60930 — Remote Start/Stop Cable for 6890A GC 200
- G1530-60600 — RS-232 Cable for 6890A or 5890 Series II GCs 201



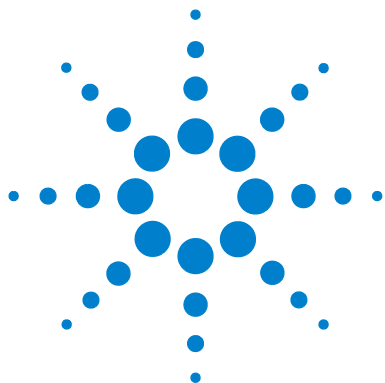

## Safety and Regulatory Information

Important Safety Warnings	12
Many internal parts of the instrument carry dangerous voltages	12
Electrostatic discharge is a threat to instrument electronics	12
Safety and Regulatory Certifications	13
Information	13
Symbols	14
Electromagnetic compatibility	15
Sound Emission Certification for Federal Republic of Germany	15
Fuses and Battery	16
Cleaning	16
Recycling the Product	16

This chapter provides important safety and regulatory information about the Agilent 7683B Automatic Liquid Sampler system.



## Important Safety Warnings

There are several important safety notices that you should always keep in mind when using the Automatic Liquid Sampler.

### Many internal parts of the instrument carry dangerous voltages

If the instrument is connected to a power source, even if the power switch is off, potentially dangerous voltages exist on:

- The wiring between the instrument power cord and the AC power supply
- The AC power supply itself
- The wiring from the AC power supply to the power switch

With the power switch on, potentially dangerous voltages also exist on:

- All electronics boards in the instrument
- The internal wires and cables connected to these boards

#### **WARNING**

**All these parts are shielded by covers. With the covers in place, it should be difficult to accidentally make contact with dangerous voltages. Unless specifically instructed to, never remove a cover.**

---

#### **WARNING**

**If the power cord insulation is frayed or worn, the cord must be replaced. Contact your Agilent service representative.**

---

### Electrostatic discharge is a threat to instrument electronics

The printed circuit (PC) boards in the instrument can be damaged by electrostatic discharge. Do not touch any of the boards unless it is absolutely necessary. If you must handle them, wear a grounded wrist strap and take other antistatic precautions. Wear a grounded wrist strap any time you must remove the electronics cover.

## Safety and Regulatory Certifications

The automatic liquid sampler conforms to the following safety standards:

- Canadian Standards Association (CSA): C22.2 No. 1010.1
- CSA/Nationally Recognized Test Laboratory (NRTL): UL 61010A-1
- International Electrotechnical Commission (IEC): 61010-1
- EuroNorm (EN): 61010-1

The instrument conforms to the following regulations on Electromagnetic Compatibility (EMC) and Radio Frequency Interference (RFI):

- CISPR 11/EN 55011: Group 1, Class A
- IEC/EN 61326
- AUS/NZ 

This ISM device complies with Canadian ICES-001. Cet appareil ISM est conforme a la norme NMB-001 du Canada.



The instrument is designed and manufactured under a quality system registered to ISO 9001.

### Information

The Agilent Technologies Automatic Liquid Sampler meets the following IEC (International Electrotechnical Commission) classifications: Safety Class I, Transient Overvoltage Category II, Pollution Degree 2.

This unit has been designed and tested in accordance with recognized safety standards and is designed for use indoors. If the instrument is used in a manner not specified by the manufacturer, the protection provided by the instrument may be impaired. Whenever the safety protection of the Agilent Automatic Liquid Sampler has been compromised, disconnect the unit from all power sources and secure the unit against unintended operation.

Refer servicing to qualified service personnel. Substituting parts or performing any unauthorized modification to the instrument may result in a safety hazard.

## Symbols

Warnings in the manual or on the instrument must be observed during all phases of operation, service, and repair of this instrument. Failure to comply with these precautions violates safety standards of design and the intended use of the instrument. Agilent Technologies assumes no liability for the customer's failure to comply with these requirements.

See accompanying instructions on [page 57](#) for more information.



Indicates a hot surface.



Indicates hazardous voltages.



Indicates earth (ground) terminal.



Indicates explosion hazard.



Indicates electrostatic discharge hazard.



## Technical and environmental specifications

- Indoor use only in ordinary atmospheres
- Altitude up to 4300 m
- Operating ambient temperatures between -5 degrees centigrade and 45 degrees centigrade
- Maximum relative humidity of 80 % for temperatures up to 31 degrees centigrade decreasing linearly to 50 % relative humidity at 40 degrees centigrade
- Main supply voltage fluctuations up to  $\pm 10\%$  of the nominal voltage
- Pollution degree 2, Installation Cat II
- G2912A is rated for mains connection to 100–120 VAC or 220–240 VAC, 50/60 Hz, 180 VA

## Electromagnetic compatibility

This device complies with the requirements of CISPR 11. Operation is subject to the following two conditions:

- 1 This device may not cause harmful interference.
- 2 This device must accept any interference received, including interference that may cause undesired operation.

If this equipment does cause harmful interference to radio or television reception, which can be determined by turning the equipment off and on, the user is encouraged to try one or more of the following measures:

- 1 Relocate the radio or antenna.
- 2 Move the device away from the radio or television.
- 3 Plug the device into a different electrical outlet, so that the device and the radio or television are on separate electrical circuits.
- 4 Make sure that all peripheral devices are also certified.
- 5 Make sure that appropriate cables are used to connect the device to peripheral equipment.
- 6 Consult your equipment dealer, Agilent Technologies, or an experienced technician for assistance.
- 7 Changes or modifications not expressly approved by Agilent Technologies could void the user's authority to operate the equipment.

## Sound Emission Certification for Federal Republic of Germany

### Sound pressure

Sound pressure  $L_p < 57$  dB(A) according to DIN-EN 27779 (Type test).

### Schalldruckpegel

Schalldruckpegel  $LP < 57$  dB(A) nach DIN-EN 27779 (Typprüfung).

## Fuses and Battery

[Table 1](#) lists the fuses in the G2912A ALS Controller and G2612A ALS Interface Board required for proper operation. Fuses in the G2912A power line module may be replaced by users. Other fuses should only be accessed by Agilent service personnel.

There are no fuses in the other 7683B Automatic Liquid Sampler components.

**Table 1** Fuses

Fuse designation	Location	Fuse rating and type
2A	G2912A Power line module	2A 250V, type T (220–240 V power supply)
2A	G2912A Power line module	2A 250V, type T (100–120 V power supply)
F1	G2912A Power supply board	1A 250V, glass body, time lag
F1	G2912A ALS controller board	7A 125V
F1	G2612A ALS controller board, used in 6890 Plus GC.	7A 125V

The G2912A ALS Controller also contains one 3 V lithium ion battery.

## Cleaning

To clean the unit, disconnect the power and wipe down with a damp, lint-free cloth.

## Recycling the Product

For recycling, contact your local Agilent sales office.



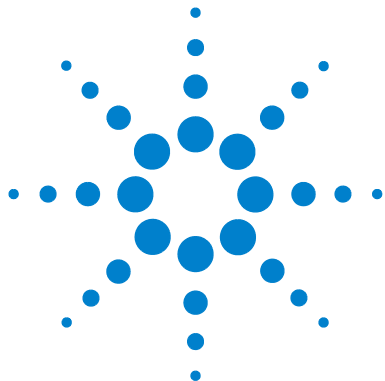

## Part 1: Installation

Introduction to Installation	19
Compatibility	20
Overview	22
Hardware Identification	23
Installation	25
The Installation Process	26
Procedure 1. Installing the G2916-61000 Injector Bracket	29
Procedure 2. Installing the G2916A Tray	35
Procedure 3. Installing the Injectors	42
Procedure 4. Connecting Cables	46
Procedure 5. Installing the G2911AA Software on the PC	50
Procedure 6. Installing the G2614A Tray	51
Procedure 7. Installing the G2615A Bar Code Reader	53
Procedure 8. Install the G2912A ALS Controller	55
Procedure 9. Replacing the Inlet Chassis Cover (6890A)	60
Procedure 10. Installing a G2612A Controller Board (6890 Plus)	61
Procedure 11. Configuring Your GC and Data System	65
Procedure 12. Updating the Firmware	66
Making A Trial Run	68





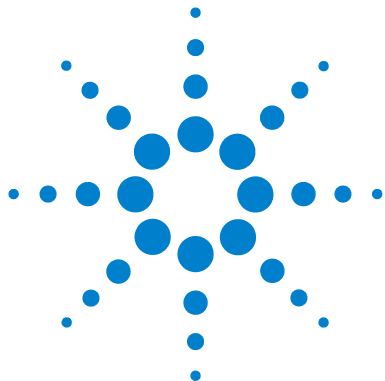

# 1 Introduction to Installation

Compatibility	20
Hardware	20
Firmware	20
Overview	22
The controller	22
The injector	22
The tray	22
The Bar Code Reader	22
Hardware Identification	23
5890A GCs that have been fully upgraded to Series II	23
5890 Series II GC	23
6890A, 6890 Plus, and 6890N GCs	24
6850A and 6850 Series II GCs	24
G2614A and G2916A trays	24
Injectors	24
Injector mounting posts	24

This chapter assists you in determining whether the 7683B ALS is suitable for your GC and aids in identifying existing equipment.



## Compatibility

### Hardware

The 7683B Automatic Liquid Sampler (ALS) system is compatible with these Agilent gas chromatographs

- 4890 GCs
- 5890A GCs that have been fully upgraded to a 5890 Series II instrument (“fully” means that both electronic and mechanical upgrades have been performed; a printed circuit board-only upgrade does not qualify).
- 5890A Series II GCs
- 6850 GCs
- 6890A GCs
- 6890 Plus GCs
- 6890N GCs

It is not compatible with non-upgraded 5890A GCs.

### Firmware

The 7683B ALS components (G2614A, G2913A, G2916A, G2912A) require minimum firmware revisions for the GC used with the system. [Table 2](#) lists these requirements.

**Table 2** Minimum GC firmware revisions for 7683B use

GC type	Minimum firmware version required
6890A	A.03.08 (chip set)
6890 Plus	A.03.08 (chip set)
6890N	A.05.04
6850 with serial number < US00003200	A.03.03
6850 with serial number > US10243001 (includes 6850 Network and Series II)	A.05.03
6850 handheld controller (G2629A)	A.05.02

If using existing 7683A components, they must also be upgraded to the latest firmware revisions for compatibility with 7683B. See [Table 3](#).

**Table 3** Minimum 7683 firmware revisions for 7683B use

<b>GC type</b>	<b>Minimum firmware version required</b>
G2913A Injector	A.11.00
G2613A Injector	A.10.07
G2614A Tray	A.02.00
G2612A ALS controller card for 6890 Plus	A.02.00
G2912A Controller	A.02.00

Failure to upgrade firmware will result in unrecognized components, vial delivery errors, or fewer available features.

If you are using the G2912A ALS Controller, the G2911AA software CD includes a firmware update utility that provides instructions for updating devices that do not require chip sets. If you do not have this CD, the firmware update utility is available on the Agilent Web site at [www.agilent.com/chem](http://www.agilent.com/chem) (search the site for “firmware”).

For more information, and for the latest available firmware updates and information, see the Agilent web site at [www.agilent.com/chem](http://www.agilent.com/chem), or contact your local Agilent sales representative.

# Overview

## The controller

The 6850 and 6890N GCs contain an internal controller for the ALS.

The 6890 Plus GC has a slot that accepts a G2612A ALS Interface Board. This adds controller capability to the GC.

The 5890 Series II and the 6890A GCs require an external G2912A controller. The controller is programmed via a PC connection (5890 Series II) or the setpoints are entered using the GC keypad (6890A).

## The injector

The G2913A injector is designed for the ALS system. The G2613A injector may also be used, but a firmware upgrade is required to use some of the features described in this manual set.

## The tray

Samples may be handled entirely with the 1-sample and 8-samples turrets supplied with the G2913A injector. An optional G2916A (5890 Series II or 6890 using the G2917A upgrade kit) or G2614A sample tray increases the capacity to 100 samples.

## The Bar Code Reader

The optional G2615A Bar Code Reader (BCR) provides a positive sample identification check. The BCR is not available for a 5890 Series II GC. Earlier BCRs are not supported.

## Hardware Identification

This section is provided to assist users who are installing a 7683B ALS system on either an existing or new GC. The actual procedures for all compatible GCs are in the next chapter; this discussion helps you select which of those procedures you need to perform.

### 5890A GCs that have been fully upgraded to Series II

These instruments can be identified from the markings on and above the oven door (Figure 1).

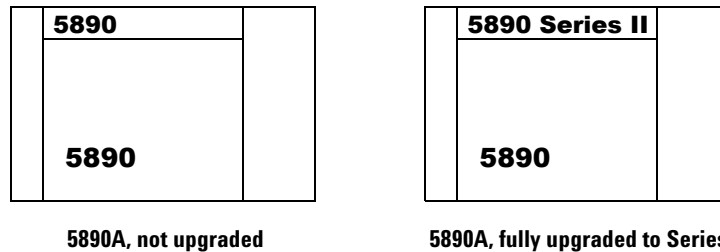

**Figure 1** 5890A GC, fully upgraded to Series II

### 5890 Series II GC

Instruments that were purchased as 5890 Series II have that information both on and above the door and on the serial number plate on the back of the instrument.

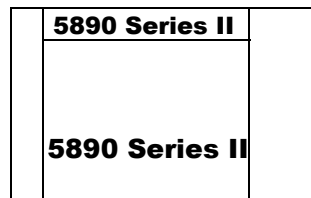

**Figure 2** 5890 Series II GC

## **6890A, 6890 Plus, and 6890N GCs**

All three instrument types can be identified by the serial number plates on the back. There have been no upgrades in this series.

## **6850A and 6850 Series II GCs**

These are tall, narrow single-column instruments. Check the serial number plate on the left side of the GC to be sure.

## **G2614A and G2916A trays**

The tray model number is on the serial number plate. Older 18596A, B, and C trays are not compatible.

## **Injectors**

**G2913A** The serial number label is on the lower back of the injector.

**G2613A** The serial number label is on the lower front of the injector.

## **Injector mounting posts**

The G2913A injector is supplied with a mounting post for use with 6890 series GCs.

If installing this injector on a 5890 Series II GC, do not use this mounting post. A special mounting post that allows this injector to be mounted to a 5890 Series II GC is supplied with the 5890 injector bracket.



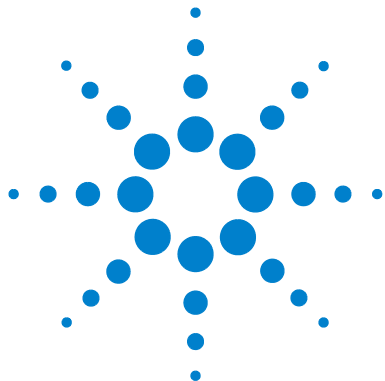

## 2 Installation

The Installation Process	26
Procedure 1. Installing the G2916-61000 Injector Bracket	29
Procedure 2. Installing the G2916A Tray	35
Procedure 3. Installing the Injectors	42
Procedure 4. Connecting Cables	46
Procedure 5. Installing the G2911AA Software on the PC	50
Procedure 6. Installing the G2614A Tray	51
Procedure 7. Installing the G2615A Bar Code Reader	53
Procedure 8. Install the G2912A ALS Controller	55
Procedure 9. Replacing the Inlet Chassis Cover (6890A)	60
Procedure 10. Installing a G2612A Controller Board (6890 Plus)	61
Procedure 11. Configuring Your GC and Data System	65
Procedure 12. Updating the Firmware	66
Making A Trial Run	68

The procedures that you need depend on what GC you are mounting the sampler on. To determine the appropriate procedures and order for your GC, see Tables 4 through 8.



## The Installation Process

The procedures for installing all or part of the 7683B ALS system depend on the GC on which you are installing it and any existing hardware that you may want to incorporate.

To install the ALS system:

- 1 Find the process table for the GC you are starting with.
- 2 Carry out the steps and procedures specified in the table.
- 3 Configure the GC and data system, if any, to use the new ALS hardware (page 65).
- 4 Check the firmware and, if necessary, update it (page 66).
- 5 If using an injector with a cool on-column inlet, adapt the injector and inlet as described in “Adapting For Cool On-Column Injection” on page 139.
- 6 Make a test run (page 66).

### 5890A, fully upgraded to Series II, and 5890 Series II GCs

**Table 4** 5890A, fully upgraded to Series II, and 5890 Series II GCs

Action	Procedure
Remove the injector, if present.	
Remove the tray, tray bracket and its supports, if present.	
Remove the controller, if present.	
Remove the injector mounting brackets, if present.	
Install the G2916-61000 injector bracket and mounting posts.	1 on page 29
Install the G2916A tray, if desired.	2 on page 35
Install 1 or 2 7683A or 7683B injectors.	3 on page 42
Install the G2912A ALS controller.	8 on page 55
Connect all cables.	4 on page 46
Install the G2911AA software on the PC.	5 on page 50
Configure your GC and Data System.	11 on page 65

## 6890A GC

**Table 5** 6890A GC

Action	Procedure
Remove the injector, if present.	
Remove the tray and its brackets, if present.	
Remove the controller, if present.	
Replace the inlet carrier cover.	9 on page 60
Install the G2614A tray <b>OR</b> Install the G2916A tray with G2917A (G2917-64000) upgrade kit.	6 on page 51 2 on page 35
Install 1 or 2 injectors.	3 on page 42
Optional. Install the G2615A Bar Code Reader.	7 on page 53
Install the G2912A ALS controller.	8 on page 55
Connect all cables.	4 on page 46
Update your Firmware.	12 on page 66
Configure your GC and Data System.	11 on page 65

## 6890 Plus GC

**Table 6** 6890 Plus GC

Action	Procedure
Remove the injector, if present. Save the 7683A injector since it can be used with the 7683B ALS system.	
Remove the 18596 A, B, or C tray and bracket if present.	
Install a G2612A ALS controller board in the GC, if not present.	10 on page 61
Install the G2614A tray <b>OR</b> Install the G2916A tray with G2917A (G2917-64000) upgrade kit.	6 on page 51 2 on page 35
Install 1 or 2 7683A or 7683B injectors.	3 on page 42
Optional. Install the G2615A Bar Code Reader.	7 on page 53

**Table 6** 6890 Plus GC (continued)

Action	Procedure
Connect all cables.	4 <a href="#">on page 46</a>
Update your Firmware.	12 <a href="#">on page 66</a>
Configure your GC and Data System.	11 <a href="#">on page 65</a>

### 6890N GC

**Table 7** 6890N GC

Action	Procedure
Install the G2614A tray <b>OR</b> Install the G2916A tray with G2917A (G2917-64000) upgrade kit.	6 <a href="#">on page 51</a> 2 <a href="#">on page 35</a>
Install 1 or 2 7683A or 7683B injectors.	3 <a href="#">on page 42</a>
Optional. Install the G2615A Bar Code Reader.	7 <a href="#">on page 53</a>
Connect all cables.	4 <a href="#">on page 46</a>
Update your Firmware.	12 <a href="#">on page 66</a>
Configure your GC and Data System.	11 <a href="#">on page 65</a>

### 6850 GC

**Table 8** 6850 GC

Action	Procedure
Install the 7683A or 7683B injector.	3 <a href="#">on page 42</a>
Connect cable.	4 <a href="#">on page 46</a>
Update your Firmware.	12 <a href="#">on page 66</a>
Configure your GC and Data System.	11 <a href="#">on page 65</a>

## Procedure 1. Installing the G2916-61000 Injector Bracket

This section contains the following information:

- Instructions for installing the injector mounting bracket for a 7683A or B Injector Module on a 5890 Series II GC.
- Instructions for aligning the injector bracket.

### Before you start

**WARNING**

**Allow the inlets and oven to cool before installing the injector bracket. The metal surfaces of the GC are very hot and could burn your skin. If you have a split/splitless inlet, you could damage the column and the alignment tools.**

**Turn off the gas flows before you remove the inlet nut or you may damage the packing in the inlet liner. Avoid contaminating the inlet while it is uncovered.**

---

Before installing the injector bracket, you must:

- 1 Remove existing injectors, tray, and injector controller.
- 2 Remove any existing tray bracket and supports ([Figure 3](#)).

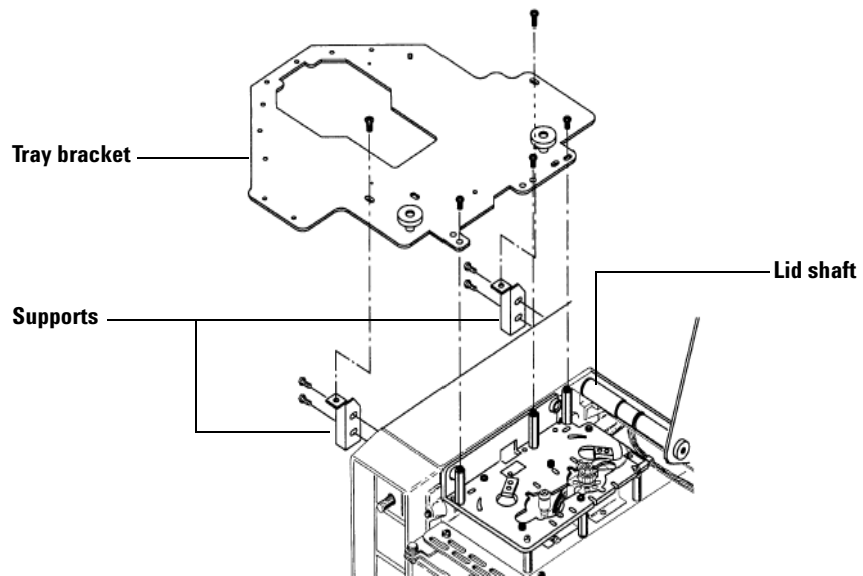

**Figure 3** Removing a tray bracket

- 3** Replace the existing lid shaft with the new lid shaft–5890 from the bracket kit. The lid shaft is held by a screw on one end.
- 4** If tubing for a split/splitless inlet is routed on top of the bracket, remove the inlet nut.

- 5 Remove the two screws attaching the bracket to the standoffs on the top of the GC. See [Figure 4](#).

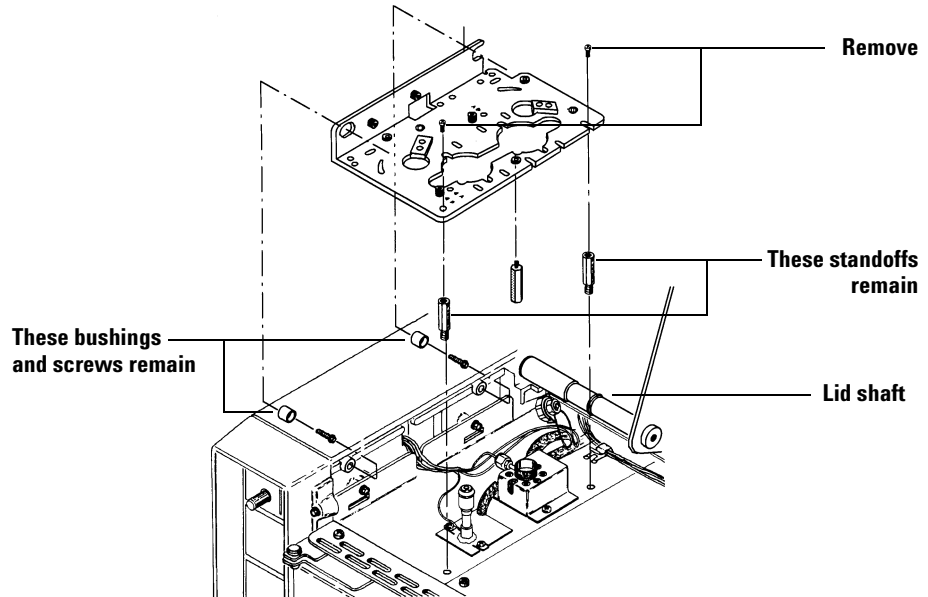

**Figure 4** Removing an injector bracket

- 6 Remove the bracket.
- 7 Reinstall any inlet nuts that were removed.

#### NOTE

Do not remove the bushings shown in [Figure 4](#) that pass through the bracket from the left or the standoffs that connect it to the top of the GC. These parts will be used to install the new bracket.

### Install the new injector bracket

- 1 Locate the plastic tabs on the back of the front bezel above the oven door. Trim the third tab from the left so that it is flush with the back edge of the bezel ([Figure 5](#)).

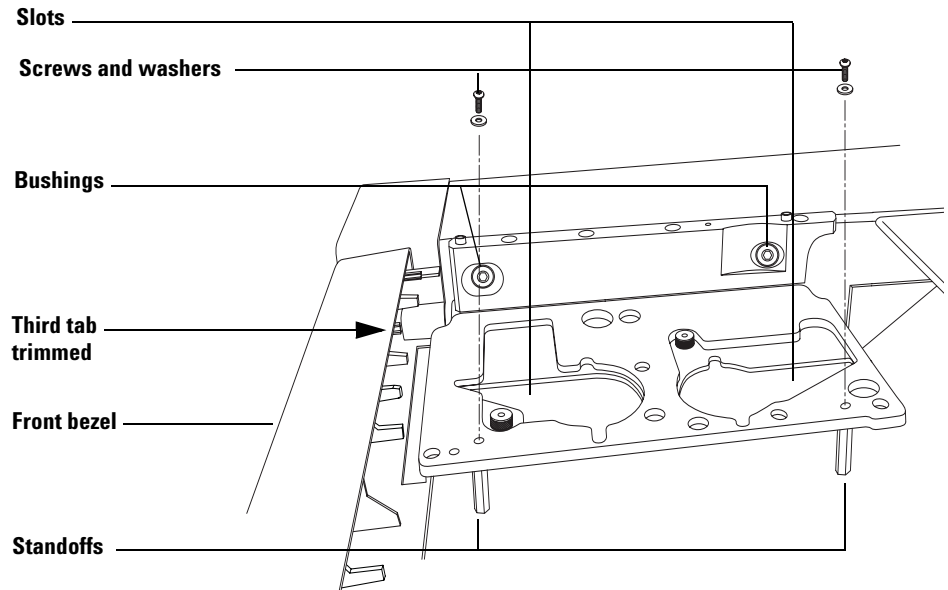

**Figure 5** Installing the injector bracket

- 2 If not present, install the two injector bracket bushings on the side frame of the GC using self-tapping screws (Figure 4). Do not overtighten the screws.
- 3 If not present, install two standoffs in the top of the GC. (Figure 5)
- 4 If a split/splitless inlet is present, attach the inlet nut and bend the thin tubing down close to the oven top. Examine the new injector bracket. The inlet tubing must be *under* the new bracket and should approach along the slots cut into the mounting bracket (see Figure 5).

### CAUTION

All inlet tubing and wiring must pass *under* the new bracket so that the injectors can install properly.

- 5 Install the injector bracket by inserting it over the side bushings and resting it on the standoffs (see Figure 5).



- 6 Install two screws and washers through the bracket into the standoffs to loosely hold the bracket (see [Figure 5](#)). Do not tighten the screws.

**NOTE**

Bracket alignment is critical for proper sampler operation.

If you have an on-column inlet, install the cooling tower before starting alignment.

- 7 Place the plastic alignment tool(s), honeycombed side up, over the GC inlet(s). See [Figure 6](#). Move the bracket until both alignment tools fit flush on the bracket.

If you cannot make them fit flush by moving the bracket, you will have to adjust the positions of the inlets. Loosen the two screws that hold the inlets to the oven top. Once aligned, tighten the two inlet screws.

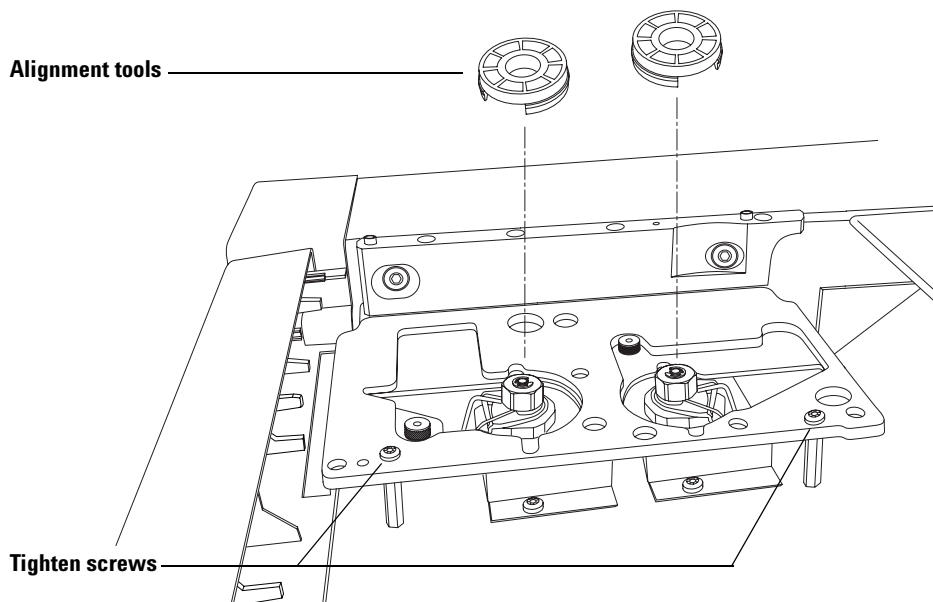

**Figure 6** Aligning the injector bracket

- 8 Tighten the two screws that hold down the bracket. Remove the alignment tools and save them for future adjustments.

### CAUTION

In the following step, use a flat blade screwdriver that snugly fits the slot in the top of the posts. An undersized blade can damage the post top and prevent the injector from mounting properly.

- 9 Install the injector mounting posts from the kit (Figure 7). Use a flat blade screwdriver that fits the slot in the top of the posts. Be careful not to damage the tops of the posts by using an undersized screwdriver. The post must be firmly tightened to the bracket to prevent injector movement.

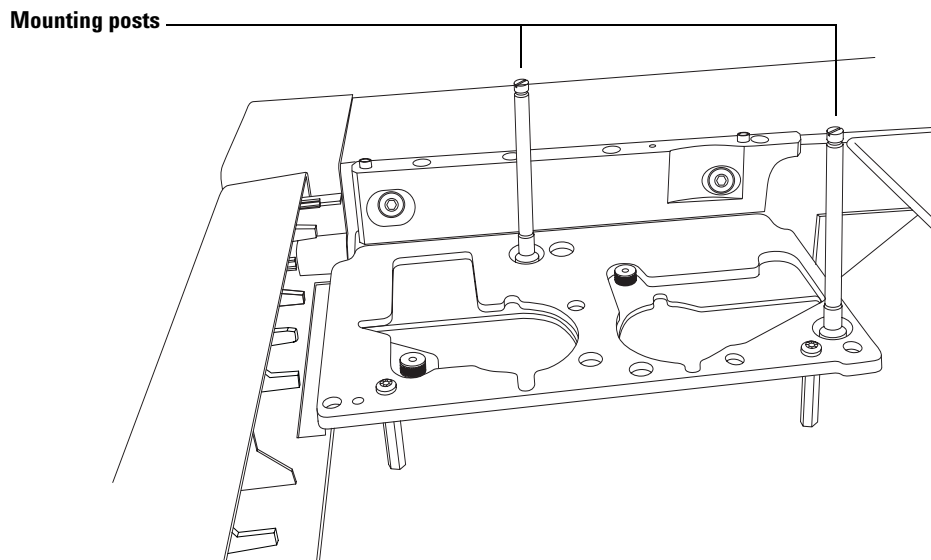

**Figure 7** Installing the mounting posts

### Check your work

- ✓ If the GC has a packed or split/splitless inlet, check the inlet nut.
- ✓ If the GC has an on-column inlet, be sure that you have removed the cooling tower from the septum nut base assembly.
- ✓ All inlet wiring and gas lines are routed under the bracket.
- ✓ All the screws, bushings, and mounting posts are in place.

## Procedure 2. Installing the G2916A Tray

### 5890 Series II GC

When the sample tray is installed, it blocks access to the pneumatics door on the left side panel. To maintain easy access to these components, Agilent recommends the following:

- 1 Remove the GC left side panel.
- 2 Remove the pneumatic compartment access door from the left side panel.
- 3 Reinstall the left side panel.
- 4 Install the tray post in the hole in the right front corner (as you face the oven) of the bracket ([Figure 8](#)).
- 5 Set the tray on the injector bracket so that the frontmost pin on the injector bracket fits into the mating hole in the bottom of the tray, then align the tray to the second alignment pin on the injector bracket.

6 Tighten the screws to secure the tray to the bracket.

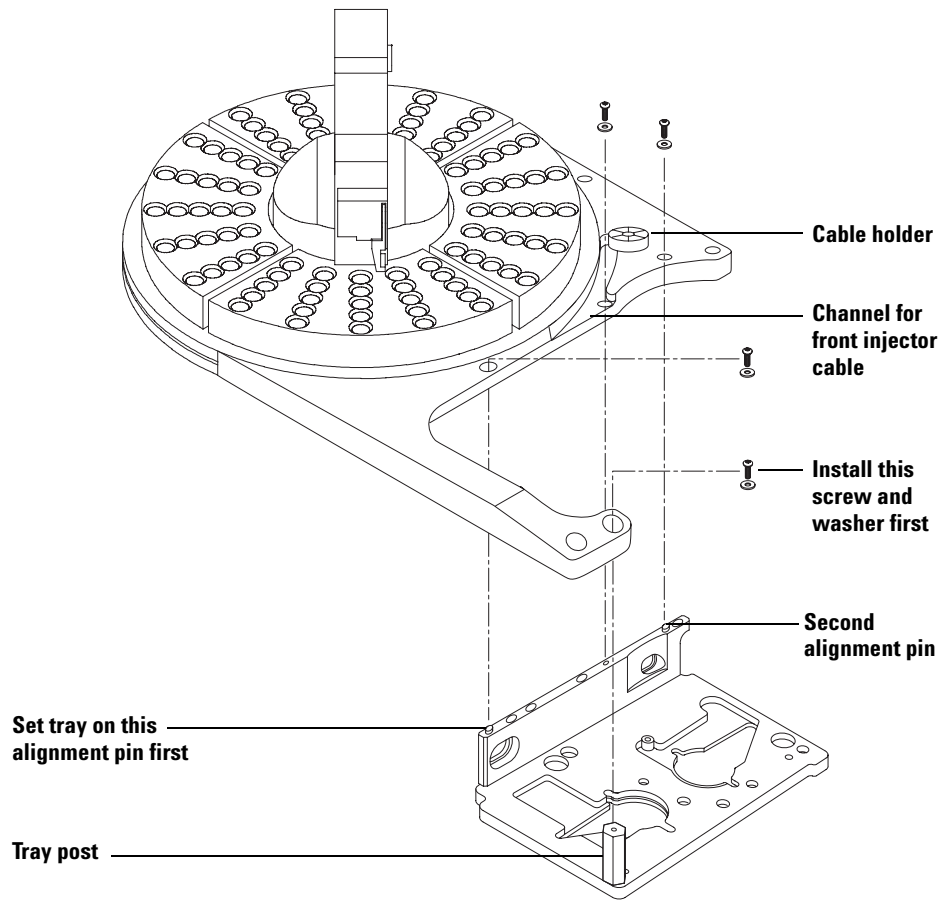

**Figure 8** Installing the tray

- 7 Install the tray quadrants (Figure 9). Be sure to match the numbers on the quadrants with the tray base numbers.

Slide the leading edge of each quadrant under the guides on the tray, then snap the front tab into the slot on the tray.

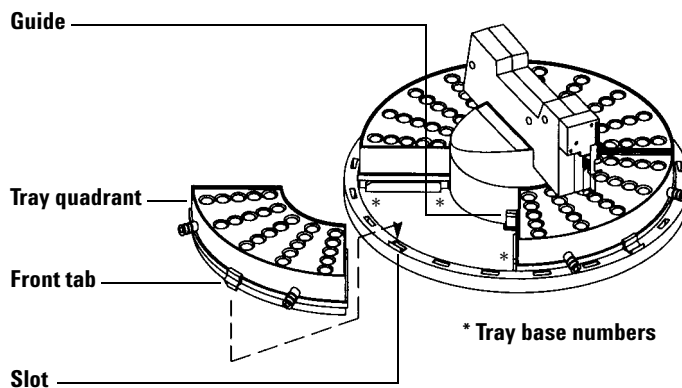

**Figure 9** Install the tray quadrants

## 2 Installation

### 6890 GC

The G2917A upgrade kit is available to convert a G2916A tray for use on a 6890 GC.

- 1 The cosmetic cover is screwed to the bracket to protect it during shipping. Remove the one screw and plastic washer and separate the parts. See [Figure 10](#).

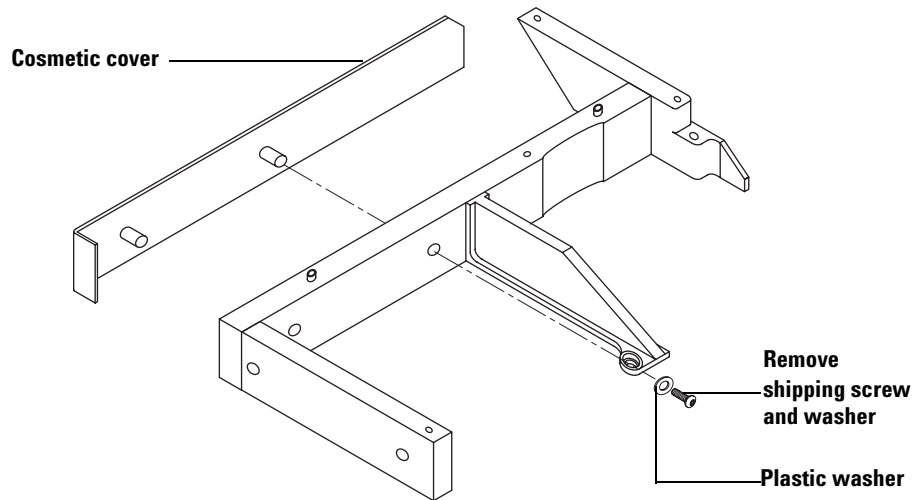

**Figure 10** Remove the cosmetic cover

- 2 Install the cosmetic cover on the side of the bracket using the two supplied screws. See [Figure 11](#).

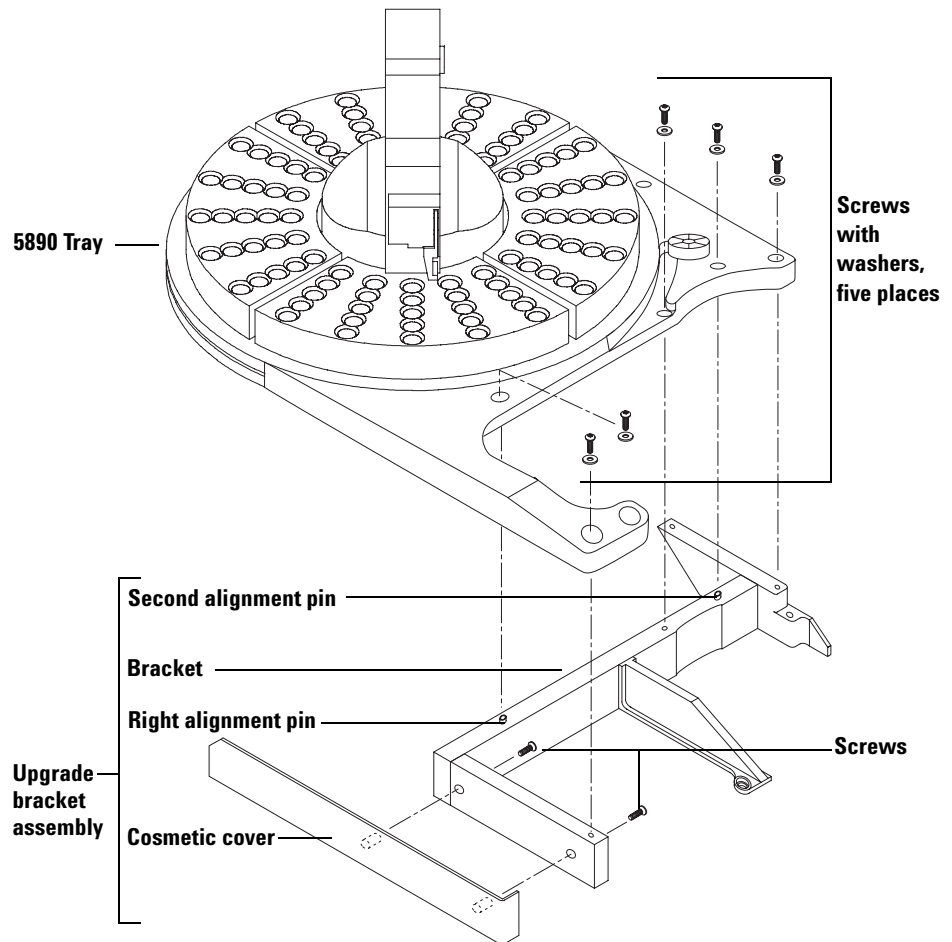

**Figure 11** Installing the upgrade bracket

- 3 Set the tray on the upgrade bracket from the kit so that the frontmost pin on the upgrade bracket fits into the mating hole in the bottom of the tray (Figure 11). Align the tray to the second alignment pin on the upgrade bracket.
- 4 Tighten the screws to secure the tray to the upgrade bracket.

- 5 Remove the three inlet cover Torx screws (Figure 12).

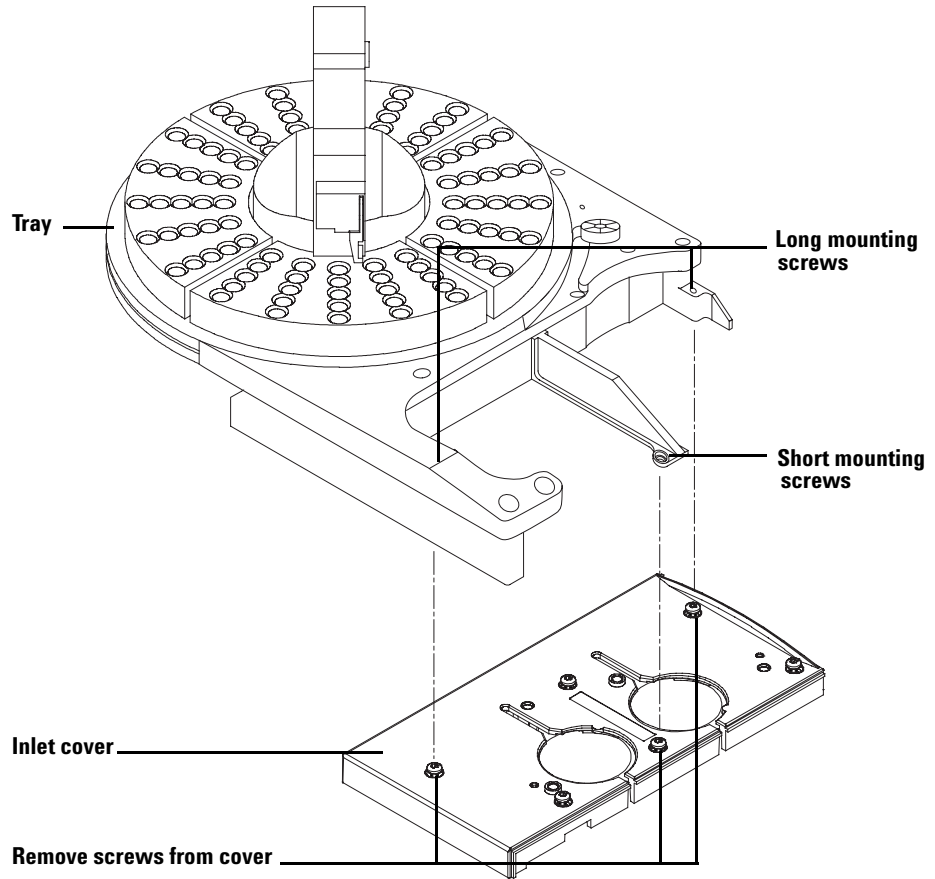

**Figure 12** Installing the tray

### CAUTION

Do not move or manipulate the robotic arm or gripper. Moving the arm or gripper back and forth can cause damage. If necessary, rotate the arm assembly a few degrees until there is enough clearance.

- 6 Align the tray over the two left holes in the inlet cover. Tighten the short screw in the center of the tray mounting arm to hold the tray. Install the two long mounting screws into the tray and tighten until the tray is secure.



- 7 Install the tray quadrants (Figure 13). Be sure to match the numbers on the quadrants with the tray base numbers.

Slide the leading edge of each quadrant under the guides on the tray, then snap the front tab into the slot on the tray.

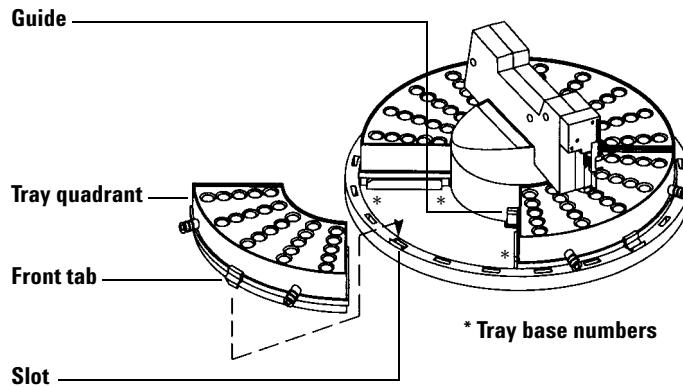

**Figure 13** Install the tray quadrants

## Procedure 3. Installing the Injectors

### Installing the injector on the GC

**CAUTION**

Do not mount a G2613A or G2913A Injector on a mounting post for a 7673 Injector; this can damage the injector. Remove the old post and replace it with the new one.

Do not use the 5890 injector bracket mounting post with other GC models. Do not use 6850/6890 injector mounting posts on a 5890 GC.

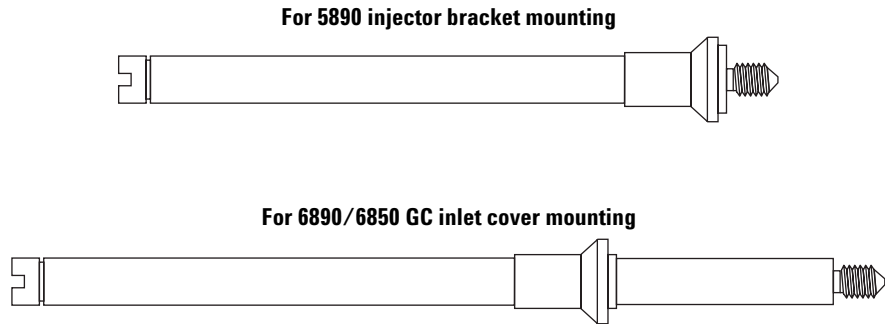
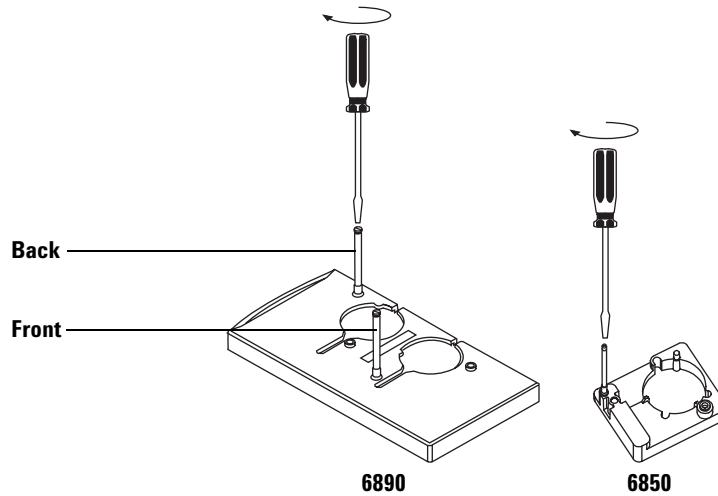

**Figure 14** Mounting posts

**CAUTION**

In the following steps, use a flat blade screwdriver that snugly fits the slot in the top of the posts. An undersized blade can damage the post top and prevent the injector from mounting properly,

- 1 If not installed, install the mounting post. See [Figure 14](#).
  - 6890. Install into the injection port cover in the front or rear location, as desired. The post must be turned all the way down. See [Figure 15](#).
  - 6850. Install into the inlet mounting bracket. Loosen the inlet screws, install the post and tighten the screws. The post must be turned all the way down. See [Figure 15](#).
  - 5890 Series II. See [Figure 7](#).



**Figure 15** Installing the injector post (6890 and 6850 GCs)

- 2 Open the injector door and remove any packing material. Slide the syringe carriage down, then remove the remaining packing material above the turret.
- 3 Mount the injector (Figure 16). Line up the hole in the base of the injector near the cable with the mounting post. Lower the injector about an inch (2.5 cm) onto the post.

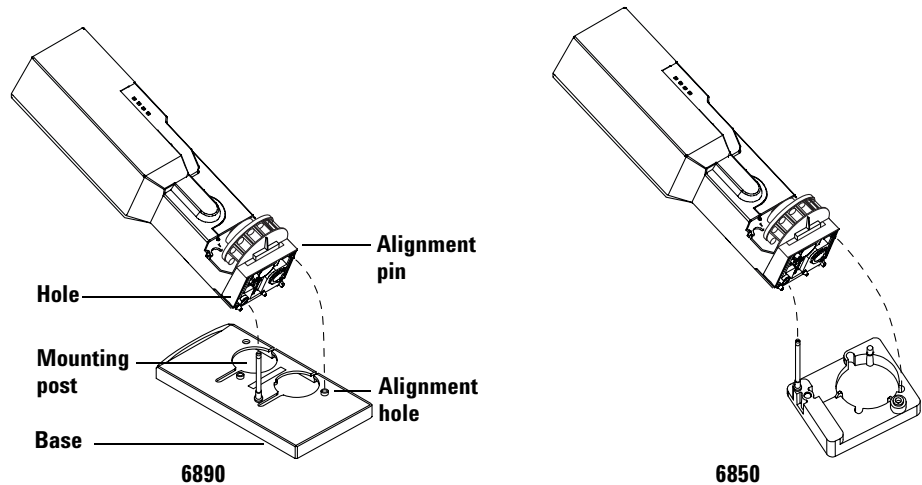

**Note:** 5890 Series II installation is not shown, but is similar to installation on a 6890.

**Figure 16** Mounting the injector

**Front location** Turn the injector so that the turret is facing the front of the GC. Lower the injector until the alignment pin in the base enters the alignment hole in the inlet cover. If using a G2916A tray, route the injector cable to the right through the channel in the front of the tray and under the cable holder (see [Figure 8](#)). If using a G2614A tray, route the cable to the right and under the cable guide.

**Back location** Turn the injector so the turret faces the left side of the GC. Lower the injector until the alignment pin in the base enters the alignment hole in the inlet cover.

## Check your work

The injector must be vertical.

The alignment pin must be properly seated in the alignment hole.

The injector feet should touch the inlet cover.

If the injector will not sit upright on the GC, check that the plumbing and cabling under the inlet cover are properly routed in their channels.

## Choosing the turret type

The G2913A injector comes with two turrets, a 1-sample transfer turret for use with or without a tray, and an 8-sample turret to be used without a tray. The injector comes with the transfer turret installed.

If you choose not to use the tray, you may remove the 1-sample turret and install the 8-sample turret. See [“Changing the Turret”](#) on page 147 for details.

If using a G2613A injector with a tray, install the 3-sample turret.

If using a G2913A injector with a tray, install the 1-sample turret.

## Procedure 4. Connecting Cables

Figures 17 through 20 show the cabling required for installing a 7683B system on a GC.

### 5890 Series II GC

Follow the instructions below to properly wire the G2912A controller. See “[Procedure 8. Install the G2912A ALS Controller](#)” on page 55 for installation instructions for the G2912A controller including the power supply cord.

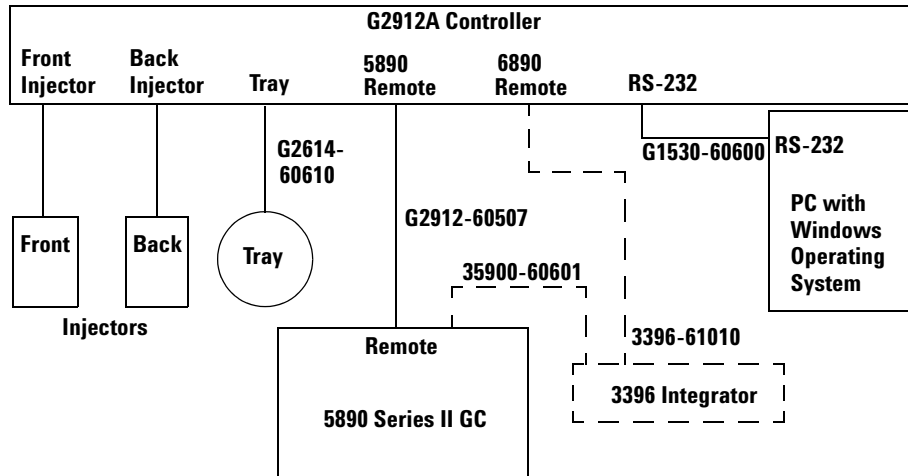

Power cords not shown

**Figure 17** Cables for 5890 Series II GC

- 1 Connect the injector(s) to the controller.
- 2 Connect the tray to the controller with a G2614-60610 cable.
- 3 Connect the PC to the controller with a G1530-60600 cable.
- 4 Connect the controller to the GC with a G2912-60507 cable.
- 5 Optionally connect the 3396 Integrator to the 5890 GC with a 35900-60601 cable and to the controller with a 3396-61010 cable. See your 3396 Integrator documentation for wiring the analog signals and power supply.
- 6 Connect the power cords.

## 6890A GC

Follow the instructions below to properly wire the G2912A controller. See “[Procedure 8. Install the G2912A ALS Controller](#)” on page 55 for installation instructions for the G2912A controller including the power supply cord.

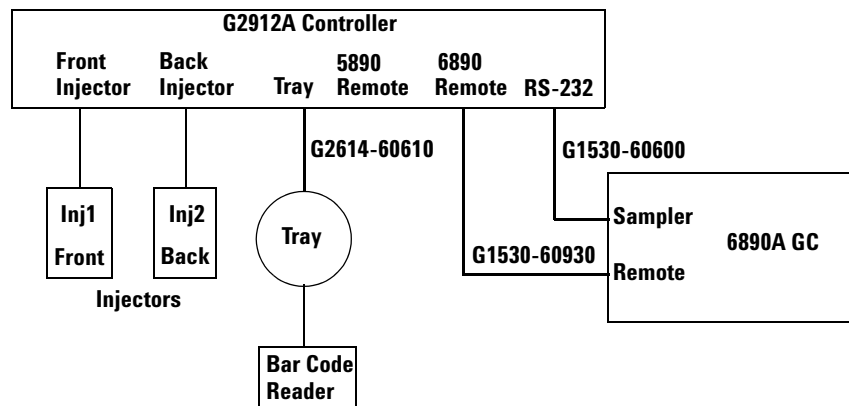

Power cords not shown

**Figure 18** Cables for 6890A GC

- 1 Connect the injector(s) to the controller.
- 2 Connect the tray to the controller with G2614-60610 cable.
- 3 Connect the controller to the GC with a G1530-60930 cable and a G1530-60600 cable.
- 4 Connect the Bar Code Reader to the tray, if desired.
- 5 Connect the power cords.

## 6890 Plus and 6890N GCs

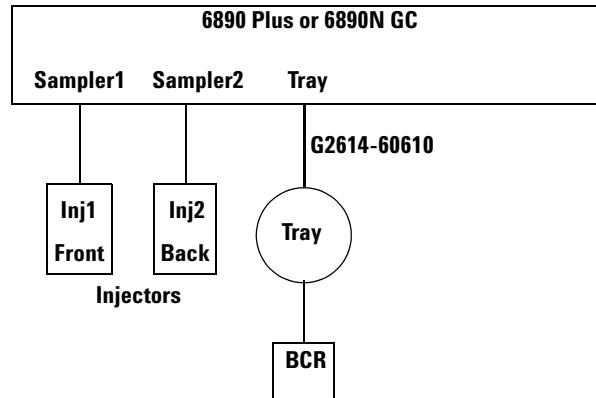

Power cords not shown

**Figure 19** Cables for 6890 Plus and 6890N GCs

- 1 Connect the injector(s) to the GC.
- 2 Connect the tray to the GC with the G2614-60610 cable.
- 3 Connect the Bar Code Reader to the tray, if desired.
- 4 Connect the GC power cord.



## 6850 GC

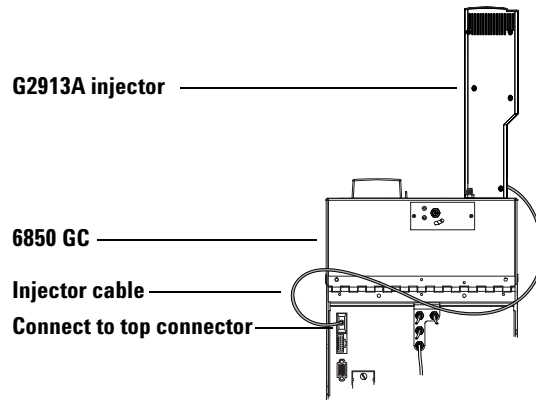

**Figure 20** Cable for 6850 GC

Connect the injector cable as shown. Use the top connector on the back of the GC.

### Testing the connections

When the cables are connected, turn on the GC power. The tray will beep twice. After the start-up process ends:

- The Ready light on the injector tower should be on.
- If the Align Mode light is on, see [“Align Mode”](#) on page 150.
- If either the Fault or Run light is on, see [“Faults”](#) on page 160.

### Procedure 5. Installing the G2911AA Software on the PC

#### NOTE

This procedure is for the 5890 Series II GC only.

---

- 1 Insert the CD into the PC attached to the controller.
- 2 A welcome screen will start automatically. Follow the directions on the screen to install the software. If the welcome screen does not start, open file **start.htm** on the CD-ROM.

If the program does not start automatically, double-click **setup.exe** in the root directory of the CD-ROM.

## Procedure 6. Installing the G2614A Tray

- 1 Remove the three inlet cover Torx screws (Figure 21).

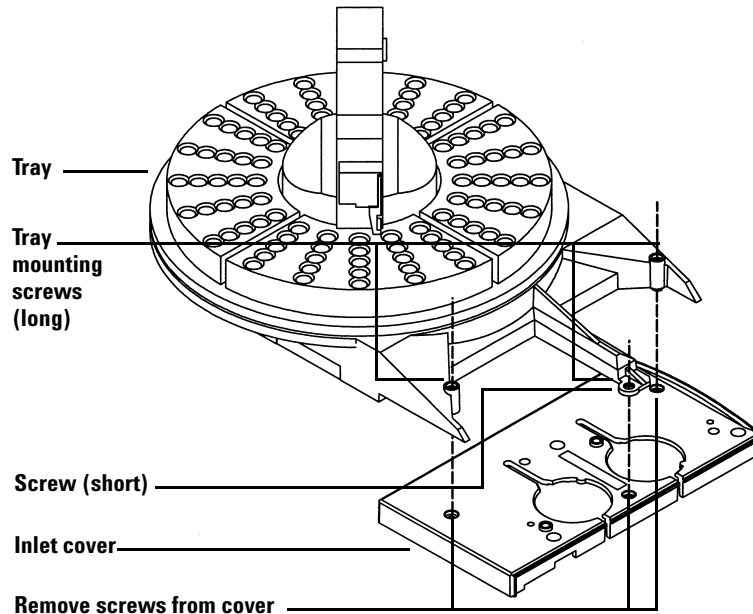

**Figure 21** Installing the tray

### CAUTION

Do not move or manipulate the robotic arm or gripper. Moving the arm or gripper back and forth can cause damage. If necessary, rotate the arm assembly a few degrees until there is enough clearance.

- 2 Align the tray over the two left holes in the inlet cover. Tighten the short screw in the center of the tray mounting arm to hold the tray. Install the two long mounting screws into the tray and tighten until the tray is secure.
- 3 Install the tray quadrants (Figure 22). Be sure to match the numbers on the quadrants with the tray base numbers.

Slide the leading edge of each quadrant under the guides on the tray, then snap the front tab into the slot on the tray.

## 2 Installation

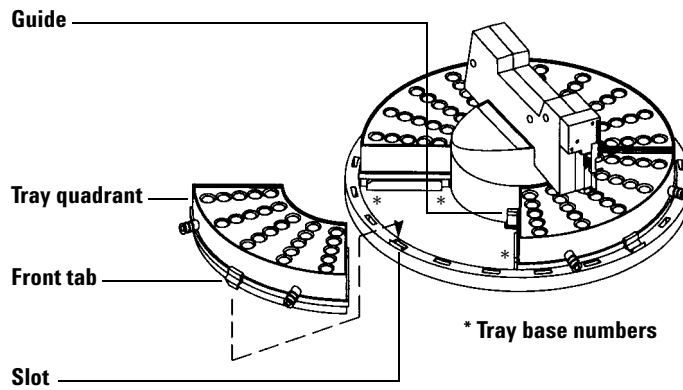

**Figure 22** Install the tray quadrants

## Procedure 7. Installing the G2615A Bar Code Reader

- 1 Locate the recess in the bottom front of the tray. The BCR must be located at this location. See [Figure 23](#).

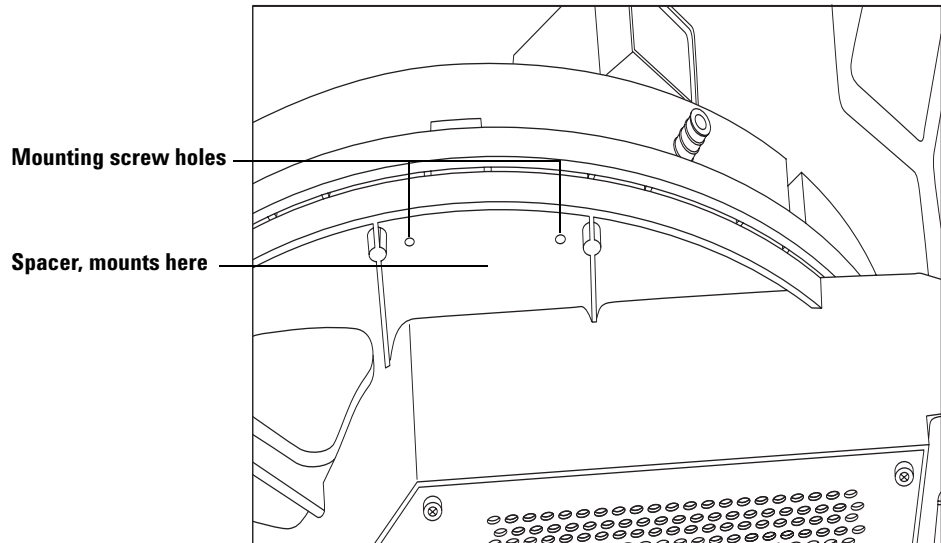
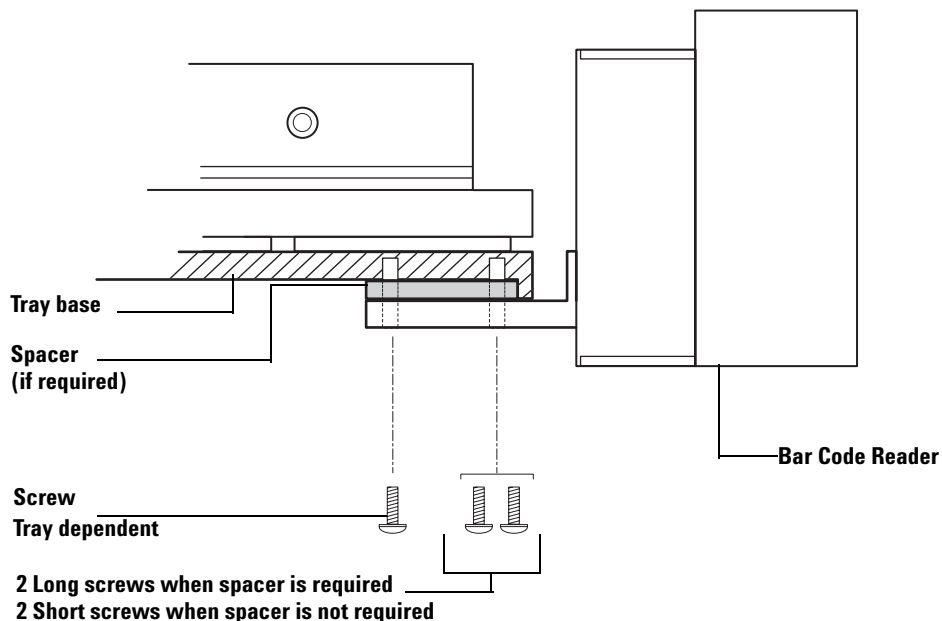

**Figure 23** The BCR spacer and mounting location

- 2 Locate the mounting screw holes. Some G2614A trays have two or three holes that are flush with the bottom of the recess. Those trays require the spacer. Newer G2614A trays have raised areas around three mounting holes and do not need the spacer. The G2916A tray when upgraded for use with a 6890 GC requires a spacer.

The tray shown in [Figure 23](#) is the two hole version. This style tray requires use of the spacer to mount the BCR.

- 3 **If the spacer is needed**, align the holes in the spacer with the mounting holes in the bottom of the tray. Place the BCR mounting bracket under the spacer, insert the two long screws and tighten them firmly. See [Figure 24](#). **If the spacer is not needed**, place the BCR mounting bracket under the mounting holes in the bottom of the tray. Insert the three short screws and tighten them firmly. See [Figure 24](#).



**Figure 24** Mounting the BCR – Side elevation

- 4 Run the cable to the back of the tray and connect it to the **Bar code** receptacle. Tighten the two securing screws. See [Figure 25](#).

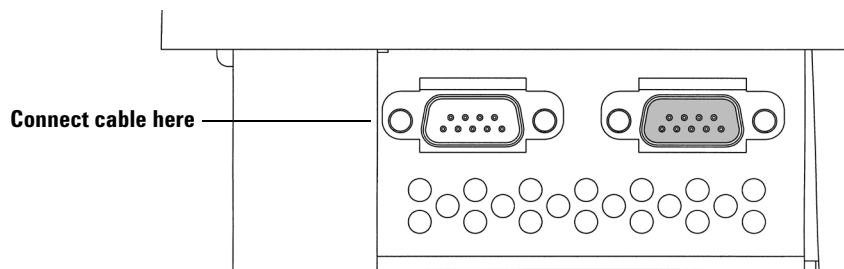

**Figure 25** Connecting the cable

- 5 This completes Bar Code Reader installation. See the section on Automatic Samplers in your Agilent 6890 Series GC user information to configure the Bar Code Reader. See [“Setting sample tray setpoints on a 6890 GC”](#) on page 91.

## Procedure 8. Install the G2912A ALS Controller

### Temperature and humidity ranges

The ALS system is designed for indoor use only in ordinary atmospheres.

Temperature range	-5 °C to 45 °C
Relative humidity range	Maximum relative humidity of 80% for temperatures up to 31 °C decreasing linearly to 50% relative humidity at 40 °C
Altitude range	Up to 2000 m

After exposing the ALS controller to extremes of temperature or humidity, allow 15 minutes for it to return to the recommended ranges.

### Ventilation requirements

The controller is cooled by air flow which enters the front of the instrument and exits through the rear. Do not obstruct air flow in the front or rear of the instrument.

### Benchtop space requirements

Figure 26 shows the space requirements around the controller. The area in the back of the controller must be kept clear for easy operation of the power switch and the front of the controller requires access to the front panel buttons.

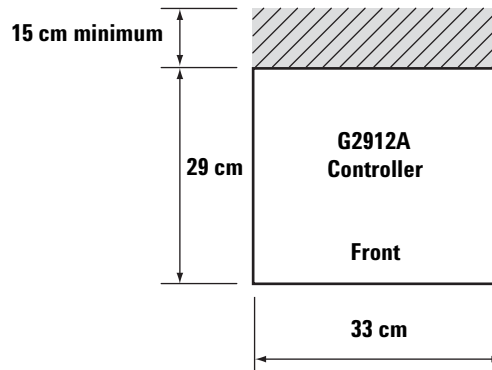

**Figure 26** Benchtop space requirements

### Dimensions

33 cm wide × 29 cm deep × 10 cm high × 4.7 kg weight



## Orientation

The G2912A ALS controller is designed to be installed in a horizontal orientation as shown in [Figure 27](#). If mounted in the incorrect vertical orientation, the probability of tipping increases with the possibility of injury to personnel.

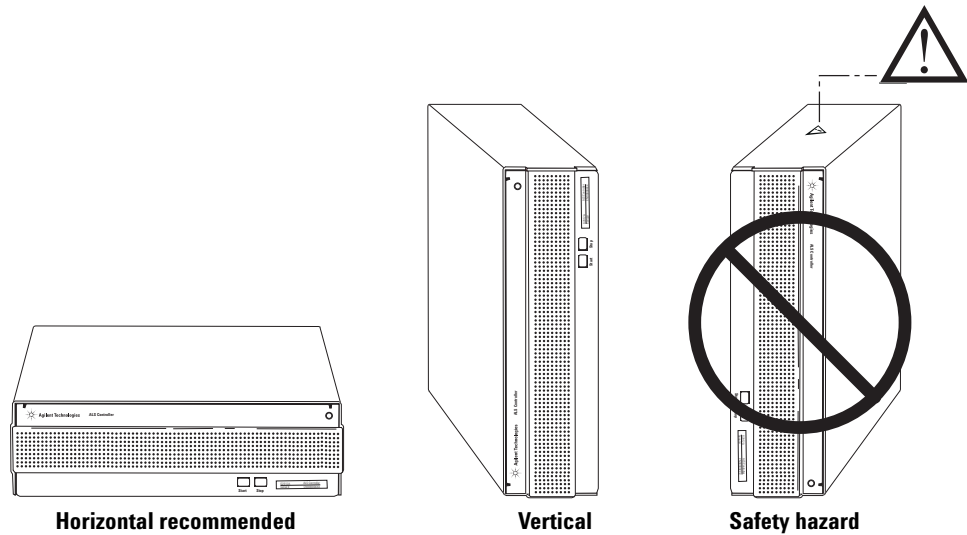

**Figure 27** ALS controller orientation

## Electrical requirements

### Grounding

#### CAUTION

A proper earth ground is required.

To protect users, the cabinet is grounded through the three-conductor power line cord in accordance with International Electrotechnical Commission (IEC) requirements.

The three-conductor power line cord, when plugged into a properly grounded receptacle, grounds the instrument and minimizes shock hazard. A properly grounded receptacle is one that is connected to a suitable earth ground. Proper receptacle grounding should be verified.

### WARNING

**Any interruption of the grounding conductor or disconnection of the power cord could cause a shock that could result in personal injury.**

### Line voltage

The G2912A ALS controller operates from one of the AC voltage supplies listed in [Table 9](#), depending on the standard voltage of the country from which it was ordered. It is designed to work at a specific voltage; make sure your instruments voltage option is appropriated for your lab. The voltage requirement is printed near the power cord attachment. See [“Verifying G2912A ALS Controller power configuration”](#) on page 59 for setting the proper voltage for this controller.

**Table 9** Voltage requirement by country

Country	Voltage	Part number
Americas, 10 amp	120 V	8120-1378
Argentina	220 V	8120-6869
Australia, 10 amp	240 V	8120-1369
Chile, 10 amp	220 V	8120-6978
China, 10 amp	220 V	8121-0723
DK/Greenland, 10 amp	220 V	8120-3997
Europe, 10 amp	230 V	8120-1689
GB/HK/SG/MY, 10 amp	240 V	8120-8705
India/S Africa, 10 amp	240 V	8120-4211
Israel, 10 amp	220 V	8120-5182
Japan, 10 amp	200 V	8120-4753
Korea, 10 amp	220 V	8121-1226
Switzerland, 10 amp	230 V	8120-2104

## Verifying G2912A ALS Controller power configuration

The G2912A ALS Controller can be configured for either 110–120 V power or for 220–240 V power.

### CAUTION

Failure to configure the correct voltage setting will blow the fuses.

To determine the current power configuration, look at the back panel of the controller. The fuse holder module below the power cord receptacle is labeled with 220–240 V on one edge and with 110–120 V on the other. See [Figure 28](#).

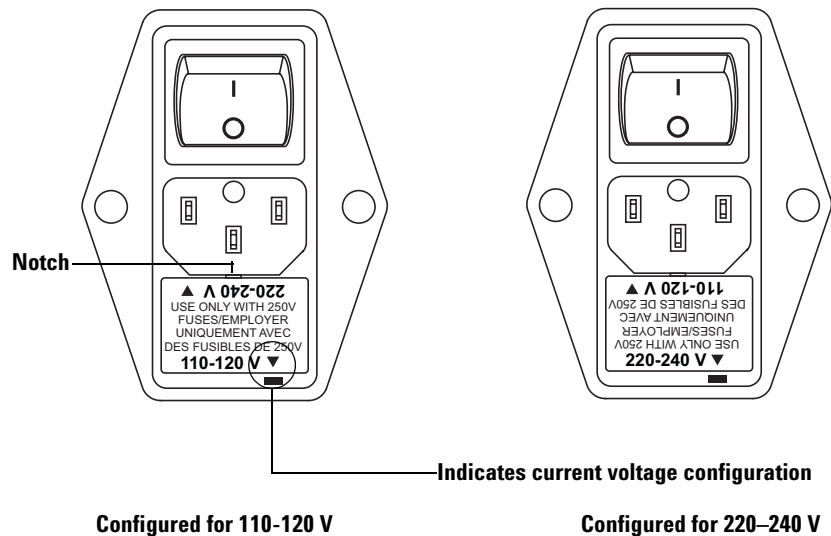

**Figure 28** G2912A power configurations

To change the power configuration, remove the fuse holder module using a small, flat-bladed screwdriver in the notch at the top of the fuse holder. Turn it over and reinstall. See [Figure 28](#).

## Procedure 9. Replacing the Inlet Chassis Cover (6890A)

The original 6890A inlet chassis cover is not compatible with 7683B components. (The inlet chassis cover is the blue plastic cover mounted over the two inlet ports.) Replace the original cover with the one supplied with the G2912A ALS Controller.

To remove the cover, remove the six Torx T-20 screws on the top of the cover and lift it off. Install the new G1530-40070 cover in its place. See [Figure 29](#). Make sure all tubing is in the correct locations.

If you will be installing a tray, you may remove the three marked screws.

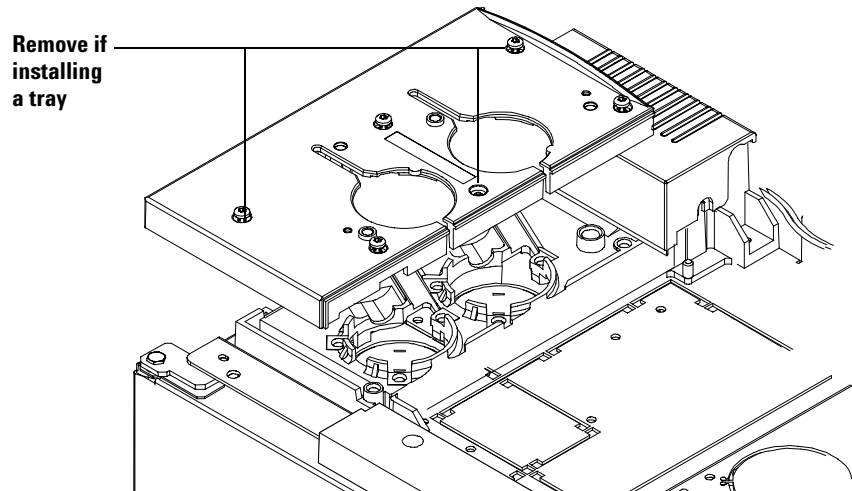

**Figure 29** Installing the G1530-40070 inlet chassis cover

## Procedure 10. Installing a G2612A Controller Board (6890 Plus)

The G2612A ALS Interface board must be present in a 6890 Plus GC to operate the 7683B Automatic Liquid Sampler. The GC must have a serial number greater than 20,000.

**WARNING**

Before proceeding, turn off the main power switch and unplug the power cord.

---

**CAUTION**

Make sure you are properly grounded with an ESD strap before continuing.

---

Follow this procedure to install the G2612A ALS Interface board.

- 1 Remove the GC rear panels and the right side cover.

**CAUTION**

Attempting to slide the entire board under the locking tab will damage the board's components.

---

- 2 Hold the board upright and slightly angled as shown in [Figure 30](#).
- 3 Place the board onto the mounting bracket.
- 4 Slide it into the bracket until the cutouts in the board are aligned with the locking tabs in the bracket.
- 5 Lay the board against the chassis then slide it in until it stops. The locking tabs should hold the board in place.

## 2 Installation

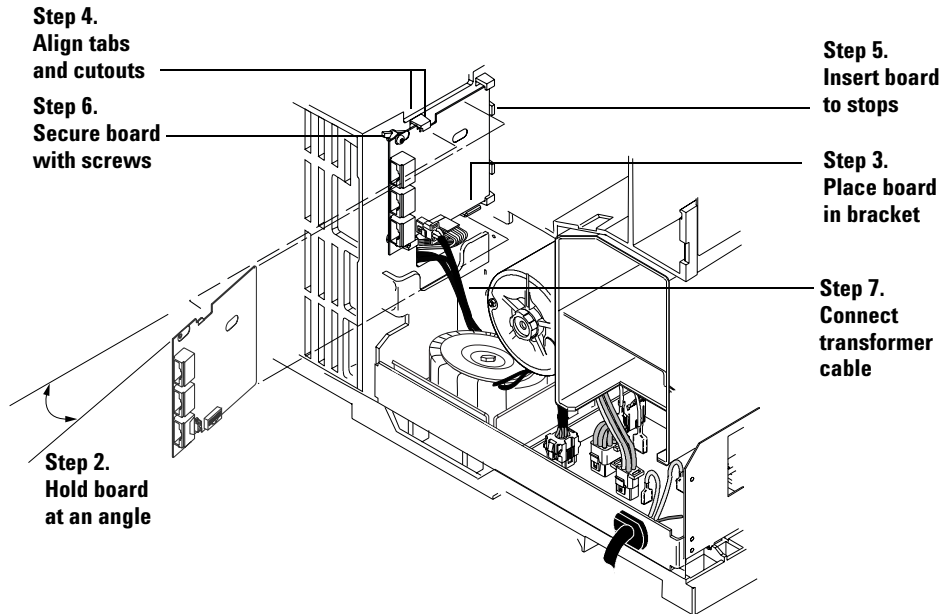

**Figure 30** Installing the ALS interface board

- 6** Secure the board to the chassis using two screws. The board should not be stressed or bowed against the locking tab. See [Figure 30](#).
- 7** Locate the 2-wire cable leading from the transformer and connect it to the ALS Interface board at J5. See [Figure 30](#) and [Figure 31](#).

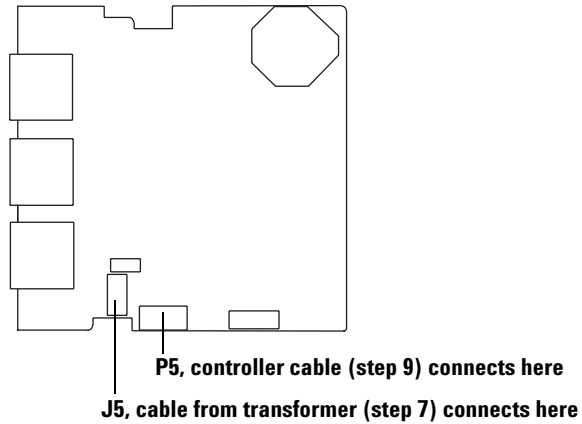

**Figure 31** ALS interface connectors

- 8 If an MIO card (LAN card) is installed, loosen its two mounting screws and slide the card out of the GC (Figure 32).

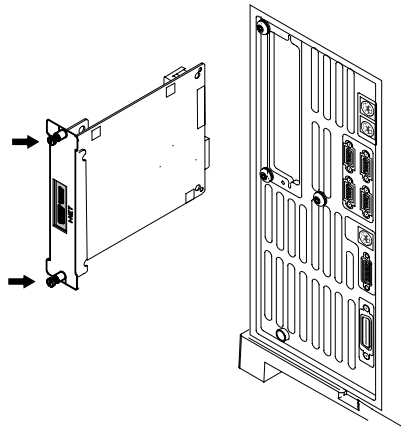

**Figure 32** Removing the LAN card

## 2 Installation

- 9 Connect the Controller PCB Cable, part no. G2612-60510, to the main board at J8 and to the ALS Interface board at P5. Route the cable through the cutout in the main board. See [Figure 31](#) and [Figure 33](#).

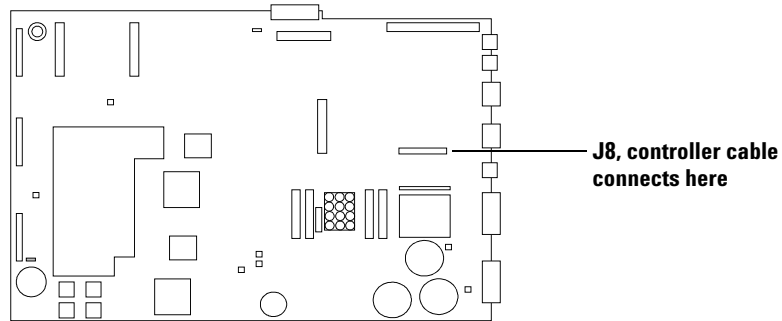

**Figure 33** GC main board

- 10 If an MIO card was removed from the GC, re-install it.
- 11 Using a nut driver, remove the cover plate over the 3 holes labeled *Injector 1 (default front)*, *Injector 2 (default back)*, and *Tray* from the rear panel. Save the plate and nuts so you can reinstall them to prevent access to the high voltage area of the GC if you ever remove the ALS interface board in the future.
- 12 Re-install the GC covers.
- 13 Restore power to the GC.



## Procedure 11. Configuring Your GC and Data System

### GC

When installation is complete, configure your GC for use with the 7683B Automatic Liquid Sampler. See “[To configure the injector](#)” on page 96 for details. Be sure to check:

- Injector usage
- Solvent bottle usage
- Solvent volume usage

For 6890 GCs, be sure to configure the front injector as **Inj1** and the back injector as **Inj2**.

### Data system

#### Configuration

Agilent ChemStation and Certy data systems contain information about the sampling equipment in use. This must be updated to remove the old information and replace it with information about the new equipment that you have installed. See the data system documentation for details.

Note that for a 5890 GC system, neither ChemStation nor Certy control the sampler. Simply deconfigure the old injector and modify your methods to use manual injection.

#### Upgrading methods

Before using methods created for a 7673 sampler, be sure to edit them as needed to match the new hardware.

## Procedure 12. Updating the Firmware

The 7683B ALS sampler requires the firmware revisions noted in [Table 10](#).

**Table 10** Minimum firmware revisions for 7683B use

<b>Instrument</b>	<b>Minimum firmware version required</b>
6890A GC	A.03.08 (chip set)
6890 Plus GC	A.03.08 (chip set)
6890N GC	A.05.04
6850 GC with serial number < US00003200	A.03.03
6850 GC with serial number > US10243001 (includes 6850 Network and Series II)	A.05.03
6850 GC handheld controller (G2629A)	A.05.02
G2913A injector	A.11.00
G2613A Injector	A.10.07
G2614A Tray	A.02.00
G2612A ALS controller card for 6890 Plus	A.02.00
G2912A controller	A.02.00

Before using the new sampler, check the firmware revisions as described below.

### All GC and ALS systems

The Agilent Firmware Update Utility, revision 4.0 or higher, will display the firmware revision of any connected device, whether GC or ALS. It is a general-purpose utility that can update the firmware on any Agilent GC or sampling device whose firmware can be flash-programmed.

To obtain the utility:

- All users can download the latest version of this utility from the Agilent Web site at [www.agilent.com/chem](http://www.agilent.com/chem). Search the site for “firmware”.

- If you are using the G2912A ALS Controller, a copy of this utility is included on the G2911AA software CD. This copy includes the minimum firmware revisions required for 7683B compatibility. For best results, check the Web site for the latest revisions.

To check and update firmware:

- 1 Install the firmware update utility on a computer that is either already connected to the devices (such as a computer running an Agilent data system) or one that can be easily connected by a cable.
- 2 Connect to the first device. The utility's help system describes in detail how to do this. In general, use an existing LAN connection (if available), or connect directly using an RS-232 cable between the computer and the device.
- 3 Use the utility to display the firmware revisions of connected hardware.
- 4 If any firmware does not meet the requirements listed in [Table 10](#), update it.

If a device meets the minimum requirements but a newer version is available, Agilent recommends updating it anyway to take advantage of the latest improvements.

## 6890A, 6890 Plus and 5890 Series II GCs

The utility can display the firmware revision for these GCs but cannot update them. These GCs use programmable chips that must be physically replaced. Contact your local Agilent representative.

## Other ways to check firmware revisions

**All GCs** Power cycle the instrument. When it reboots, it displays its firmware revision.

**All 6890 GCs** Press **Options**, then select **Diagnostics/Instrument Status**. Scroll down to see GC and injector firmware revisions and dates. The G2612A card used in the 6890 Plus is also displayed. For 6890N the tray firmware is also displayed.

**6850 GCs** Use the handheld controller. From **Status**, select **Service/Update** to display GC and injector information.

## Making A Trial Run

Once installation, configuration and updating are complete, make a quick injection using the sampler to verify that it works properly.

- 1 Install an empty syringe in the injector.
- 2 **If using a tray with a G2913A injector**, install the 1-sample turret.  
**If using a tray with a G2613A injector**, install the 3-sample turret.
- 3 Place empty bottles in all the Solvent A and Waste A turret positions. Place an empty capped sample vial in the tray 1 position (or the turret sample 1 position, if not using the tray).
- 4 Make the sampler settings shown in [Table 11](#). These are designed for a 6890N GC. If you are using a different GC, use these settings as a guide. To enter the settings:

<b>5890 Series II GC</b>	Use the G2911AA software.
<b>For 6850 GC</b>	Use the handheld controller.
<b>For 6890 GCs</b>	Use the GC keyboard.

**Table 11** Trial run parameters

Parameter	Setting
Injection volume	1
#Sample pumps	1
Viscosity delay	0
#Sample washes	1
#Solv A washes	1
#Solv B washes	0
Slow plunger	Off
Pre-dwell time	0
Post-dwell time	0
Sampling offset	Off
#Solv A pre-wash	1
#Solv B pre-wash	0
#Injections/vial	1
Samples	1-1 (for 6890 GC with tray and Agilent ChemStation control, enter 1 in vial box and run method).

- 5 Set the GC oven program to 30 °C with a 0 °C/min ramp, a hold time of 0.1 minutes, an equilibrium time of 0.3 minutes, and an initial time of 0.3 minutes.
- 6 Store, load, then run the sequence.

If there are no faults, the injector will make one injection from the first vial position.

If problems occur, see “[Faults](#)” on page 160, “[Error Messages](#)” on page 162, “[Correcting Syringe Problems](#)” on page 175, or “[Correcting Sample Vial Delivery Problems](#)” on page 176.



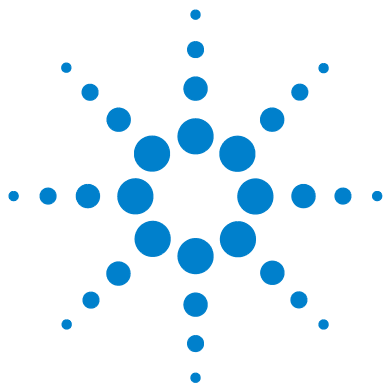

## Part 2: Operation

Introduction to Operation	73
About your 7683B Automatic Liquid Sampler	74
Capabilities	76
Fast Injection	77
Sample Carryover	79
Controlling the Sampler	81
Methods and Sequences	82
The Sampler Cycle	83
Setting Parameters on a 5890 Series II GC	85
Setting Injector Parameters on a 6890 GC	87
Setting Parameters on a 6850 Series GC	94
Syringes and Needles	99
Syringes	100
Installing a Syringe	103
Removing a Syringe	106
Replacing Syringe Needles	107
Vials and Bottles	109
Preparing Sample Vials	110
Preparing Solvent and Waste Bottles	116
Placing Vials and Bottles in the Sampler	118
Using Two Injectors (5890, 6890 only)	121
How Many Sample Vials Can I Run?	122
Running Samples	129
Running a Sample	130
Using the ALS Controller	131
Interrupting A Run Or Sequence	132
Running a Priority Sample	134







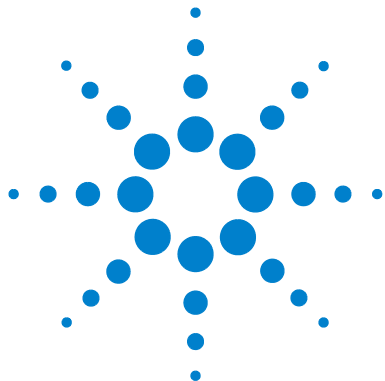

### 3 Introduction to Operation

About your 7683B Automatic Liquid Sampler	74
Capabilities	76
Fast Injection	77
Sample Carryover	79
Solvent wash	79
Sample wash	79
Sample pump	79
Number and type of washes	79

This chapter describes the modules that make up the Agilent 7683B Automatic Liquid Sampler, the sampler capabilities, and some of the important features of the system.



## About your 7683B Automatic Liquid Sampler

The 7683B Automatic Liquid Sampler system (Figure 34) can include:

- G2912A ALS controller (5890 Series II, 6890A)
- One G2612A ALS interface board (6890 Plus only)
- One or Two G2913A injector modules
- G2614A 100-vial tray (option 1, 6890)
- G2916A 100-vial tray (5890)
- G2615 Bar Code Reader (optional for 6890 series only, requires Agilent Data Systems Control)

Additionally, this liquid sampler system is fully compatible with one or two G2613A injectors.

The injector draws a sample from a 2-mL or 100- $\mu$ L vial and injects it into the gas chromatograph (GC) inlet. Two sample turrets are provided with the G2913A injector:

- An 8-sample turret allows you to analyze up to 8 samples with the turret alone. It holds two solvent and one waste bottle.
- A 1-sample transfer turret works with the optional G2614A or G2916A tray to analyze up to 100 samples. The turret holds six solvent and four waste bottles.

In addition, the sampler can:

- Perform solvent pre- and post-injection washes
- Perform sample pre-injection washes
- Perform sample pumps
- Extend the sample draw time for viscous samples
- Inject different sample amounts from different sample vials
- Interrupt a sequence to run priority samples, then resume the sequence
- Perform cool on-column injections into 250- $\mu$ m, 320- $\mu$ m, and 530- $\mu$ m columns
- Perform variable plunger speed under Agilent data system control

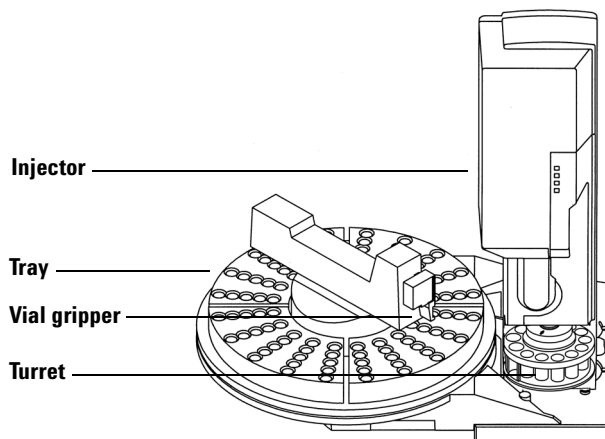

**Figure 34** The 7683 Automatic Liquid Sampler shown on a 6890 GC

## Capabilities

Table 12 summarizes the capabilities of the 7683B Automatic Liquid Sampler.

**Table 12** Automatic liquid sampler capabilities

Parameter		Range		
Syringe size		0.5, 1, 5, 10, 25, 50, or 100 $\mu\text{L}$		
Number of sample vials		Up to 8 without tray or 100 with tray		
Number of injections per vial		1 to 99		
Injection volume	Minimum	0.1 $\mu\text{L}$ (5 $\mu\text{L}$ syringe) 2% of syringe volume		
	Maximum	50.0 $\mu\text{L}$ (100 $\mu\text{L}$ syringe) 50% of syringe volume		
Plunger speed* ( $\mu\text{L}/\text{s}$ )		Slow	Fast	Variable <sup>†</sup>
	5 $\mu\text{L}$ syringe	2.5	50	<1~50
	10 $\mu\text{L}$ syringe	5	100	<1~100
	25 $\mu\text{L}$ syringe	12.5	250	<1~250
	50 $\mu\text{L}$ syringe	25	500	<1~500
	100 $\mu\text{L}$ syringe	50	1000	<1~1000
Overall injection time (approximate)		0.1 s (Standard) 4 s (Cool on-column)		
Sampling depth		-2 to +30 mm relative to default		
Sampling viscosity delay		0 to 7 s		
Number of sample prewashes		0 to 15		
Number of sample pumps		0 to 15		
Number of solvent prewashes		0 to 15		
Number of solvent post-washes		0 to 15		
Multiple injection mode (with PTV inlet only) <sup>†</sup>				
Number of injections		1 to 100		
Injection delay time		0 to 100 s		
Preinjection dwell		0 to 1 minute		
Postinjection dwell		0 to 1 minute		

\* Plunger speeds shown are for DRAW and inject. Dispense speed is the same as FAST INJECT.

† This mode is only available under Agilent data system control.

## Fast Injection

This is a method of introducing a sample to a heated inlet without the negative effect of needle fractionation.

If you are using the automatic liquid sampler for the first time, you may see some changes in the resulting chromatograms. Most of the changes are due to reducing the amount of vaporization from the needle during injection.

- The peak areas of your chromatograms may be smaller. Automatic fast injection delivers the desired setpoint volume of sample. Without fast injection, residual amounts of sample boil out of the needle and enter the inlet. This extra amount could measure up to 1  $\mu\text{L}$ .
- The peak areas of your chromatograms may show less differentiation between the low boiling and high boiling components.

Without fast injection, the sample introduced is richer in low boiling component than in high boiling ones because of fractional distillation in the needle. Not only does residual sample in the needle enter the inlet, but the low boiling components boil off first. This is needle fractionation or discrimination.

Figure 35 compares manual injection with automatic fast injection from the automatic liquid sampler for a 1- $\mu$ L sample of C<sub>10</sub> to C<sub>40</sub> paraffins in hexane.

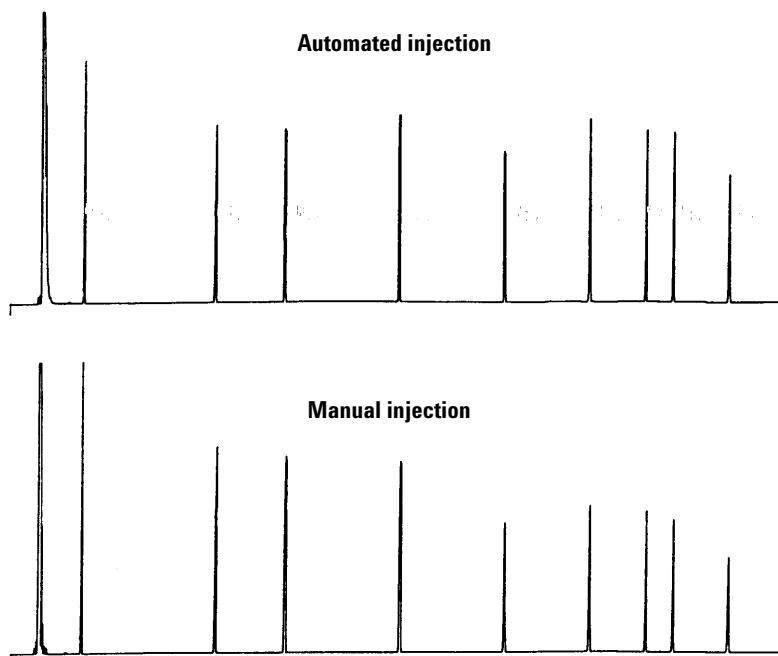

**Figure 35** Automated vs. manual injection

For more information on the performance of the automatic liquid sampler, order the following technical papers from your Agilent representative:

Publication No. 43-5953-1843: Snyder, W.Dale. Fast Injection with the 7673A Automatic Injector: Chemical Performance, Technical Paper 108, June 1985.

Publication No. 43-5953-1878: Snyder, W.Dale. Performance Advantage of the 7673A Automatic Injector Over Manual Injection, Technical Paper 109, August 1985.

Publication No. 43-5953-1879: Kolloff, R.H.C.Toney, and J.Butler. Automated On-Column Injection with Agilent 7673A Automatic Injector and 19245A On-Column Capillary Inlet: Accuracy and Precision, Technical Paper 110, August 1985.

## Sample Carryover

Carryover is the presence of peaks from an earlier injection in the present analysis.

The injector uses solvent washes, sample washes, and sample pumps to control carryover. Each of these actions reduces the amount of sample left in the syringe. The effectiveness of each depends on your application.

### Solvent wash

The injector draws solvent into the syringe from either the solvent A, A2, A3 or solvent B, B2, B3 position, then discards the syringe contents into one or more waste bottles. Solvent washes can occur before taking a sample (pre-injection solvent wash) or immediately after the injection (post-injection solvent wash). The volume of the wash can be adjusted on a 6850 or 6890 GC.

### Sample wash

During a sample wash, the injector draws the next sample into the syringe and discards the contents into one or more waste bottles. Sample washes occur before the injection. When sample is limited, you can use a solvent prewash to wet the syringe before drawing sample. The volume of the wash can be adjusted on a 6850 or 6890 GC.

### Sample pump

During a sample pump, the injector draws sample into the syringe and returns it to the sample vial. Pumps occur after sample washes and immediately before the injection. Pumps serve to eliminate bubbles. If the needle contains solvent from a previous wash, the pump may add a small amount of solvent that mixes with the sample and can dilute a small volume.

### Number and type of washes

Under ideal conditions, four default volume (80%) washes reduce the carryover to one part in 10,000. The number and type of washes you need depends on:

- The amount of carryover that you can accept
- The viscosity and solubility of the analyte(s)
- The viscosity and volatility of the solvent(s)
- The degree of wear in the syringe barrel
- The wash volume

### 3 Introduction to Operation

Chromatograms A and B (Figure 36) show the effect of carryover when 1  $\mu\text{L}$  from a vial of methanol is injected after 1  $\mu\text{L}$  from a vial of a solute dissolved in methanol. The peaks in chromatogram B are from the solute left in the syringe from the first injection.

Chromatogram C shows the result of washing the syringe with four 80% syringe volume solvent washes. The carryover peaks disappear.

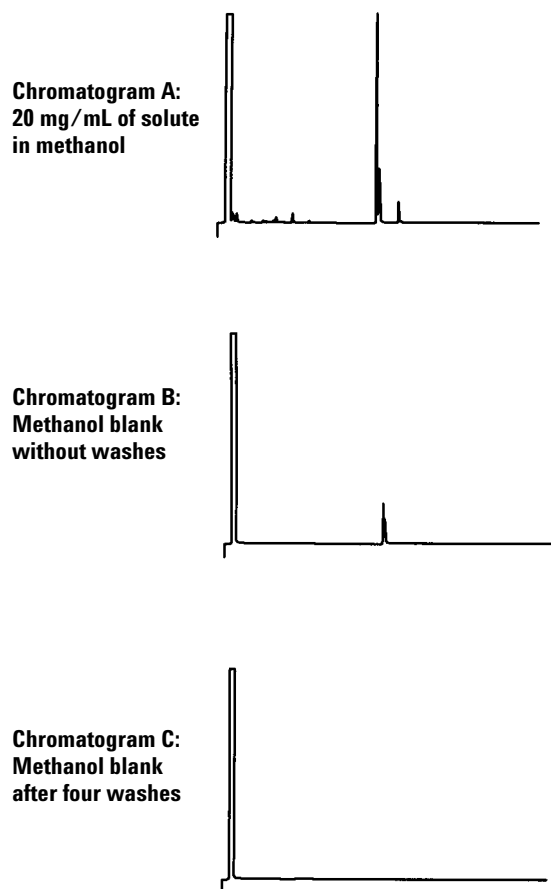

**Figure 36** Sample carryover



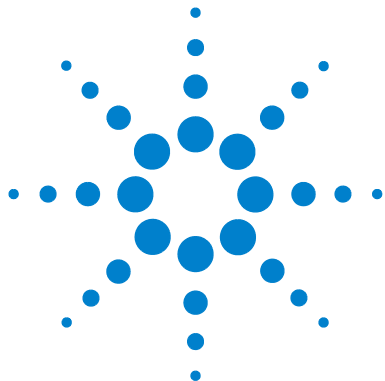

## 4 Controlling the Sampler

Methods and Sequences	82
The Sampler Cycle	83
Setting Parameters on a 5890 Series II GC	85
Setting Injector Parameters on a 6890 GC	87
Configuring the injector on a 6890 GC	89
Setting sample tray setpoints on a 6890 GC	91
Storing injector setpoints	93
Setting Parameters on a 6850 Series GC	94
To set injection parameters	94
To configure the injector	96

This chapter describes what the sampler does, the parameters that control it, and how to set those parameters using different controlling devices.



### Methods and Sequences

The sampler is usually controlled by a sequence, which is a list of samples to be analyzed. It contains:

- Where to find the sample
- What method to use to analyze the sample
- How to measure and inject the sample
- How to generate a report of analysis

A method is a collection of setpoints (temperatures, times, etc.) that controls the operation of a gas chromatograph.

The combination of a sequence and the methods it specifies provides complete control over the analysis of up to 100 samples. However, the specific details differ depending on the hardware and software used, so you are referred to other documents for that information.

This discussion is limited to sampler-specific details. For setting up methods and sequences see your GC documentation.

## The Sampler Cycle

All versions of the ALS perform the same basic operations ([Table 13](#)).

**Table 13** Sampler cycle

Step	Action	Notes
1	Transport the sample vial.	<ul style="list-style-type: none"> <li>If necessary, move the sample vial from the tray to the turret.</li> </ul>
2	Wash the syringe with solvent.	<ul style="list-style-type: none"> <li>The syringe can be washed several times and with more than one solvent. This is controlled by the solvent pre-wash parameters.</li> </ul>
	<ul style="list-style-type: none"> <li>a Rotate a solvent bottle under the syringe.</li> <li>b Lower the syringe needle into the solvent.</li> <li>c Draw in solvent.</li> <li>d Raise the syringe needle out of the solvent bottle.</li> <li>e Rotate a waste bottle under the syringe.</li> <li>f Lower the syringe. Depress the plunger to discard solvent.</li> <li>g Raise the syringe needle out of the waste vial.</li> </ul>	
3	Wash the syringe with sample.	<ul style="list-style-type: none"> <li>The syringe can be rinsed with sample several times.</li> </ul>
	<ul style="list-style-type: none"> <li>a Rotate the sample vial under the syringe.</li> <li>b Lower the syringe needle so that the needle pierces the vial septum and enters the sample.</li> <li>c Draw in sample.</li> <li>d Raise the syringe and needle out of the solvent bottle.</li> <li>e Rotate a waste bottle under the syringe.</li> <li>f Lower the syringe needle. Depress the plunger to discard sample.</li> <li>g Raise the syringe needle out of the waste vial.</li> </ul>	

## 4 Controlling the Sampler

**Table 13** Sampler cycle (continued)

Step	Action	Notes
4 Load the syringe with sample.	<ul style="list-style-type: none"><li>a Rotate the sample vial under the syringe.</li><li>b Lower the syringe needle so that it pierces the vial septum.</li><li>c Draw in sample.</li><li>d With the needle still in the sample, depress the syringe plunger quickly.</li><li>e After the final pump, draw in sample.</li><li>f Raise the syringe needle out of the sample vial.</li></ul>	<ul style="list-style-type: none"><li>• Actions <b>c</b> and <b>d</b> can be repeated several times. The purpose is to expel air bubbles from the syringe.</li></ul>
5 Inject the sample.	<ul style="list-style-type: none"><li>a Rotate the turret to expose the GC inlet.</li><li>b Lower the syringe needle so that it pierces the inlet septum.</li><li>c Depress the syringe plunger to make the injection.</li><li>d Raise the syringe needle out of the GC inlet.</li></ul>	<ul style="list-style-type: none"><li>• <b>Start</b> signals are sent to the GC and the data processor at the moment of injection.</li></ul>
6 Wash the syringe with solvent.	<ul style="list-style-type: none"><li>• Same as <a href="#">step 2</a>, but according to the post-injection parameters.</li></ul>	
7 Transport the sample vial.	<ul style="list-style-type: none"><li>• Return the sample vial to its initial turret or tray location.</li></ul>	
8 Perform repeat injections.	<ul style="list-style-type: none"><li>• If so programmed, wait for the GC to become Ready and repeat the cycle from <a href="#">step 1</a>.</li></ul>	

## Setting Parameters on a 5890 Series II GC

The injection of a sample into a 5890 Series II GC is controlled by the G2912A Controller. The controller stores the order of vials handled, vial location, wash method, injection volume, injector plunger speed, dwell time, sampling depth, and inlet and tray configuration for one or two injectors. During operation, the GC first indicates a ready condition to the sampler; the sampler then uses these stored parameters to perform an injection. The controller starts the GC run if the injection was successful.

Users can access and change these stored parameters using the G2911-64000 (G2911AA) Agilent Automated Liquid Sampler Controller for 5890 GC application. This is a standalone application and information stored in the sampler controller is not accessible by Agilent data acquisition systems applications like the Agilent ChemStation or Cerity NDIS. If your lab sampling procedure does not require constant changing of these settings, this controller application need only run when necessary. Labs requiring the flexibility of changing these parameters between the processing of groups of samples should keep this program open in Microsoft Windows alongside their data acquisition software.

For a GC with front and back injectors, leaving an injector door open before the first sample vial in a sequence is processed disables that injector for the duration of the samples processed. This is a convenient method for temporarily disabling one injector that is not required without making a configuration change using the Agilent Automated Liquid Sampler Controller for 5890 GC application. Opening an injector door at a later time when processing samples temporarily pauses the injection sequence, and the GC cannot continue until the door is closed.

### NOTE

When using the G2913A injector with 1-sample turret, the solvent capacity of each injector is six solvent bottles and the waste capacity is four bottles. When using the G2613A injector the solvent capacity of each injector is two solvent bottles. The waste capacity when using the G2613A injector is two bottles when using the tray and one bottle (waste A) when not using the tray. The B2 solvent bottle on the 3-sample turret is not available when using the G2613A injector with the 5890GC.

---

The G2911-64000 (G2911AA) Agilent Automated Liquid Sampler Controller for 5890 GC application's main window is shown in [Figure 37](#).

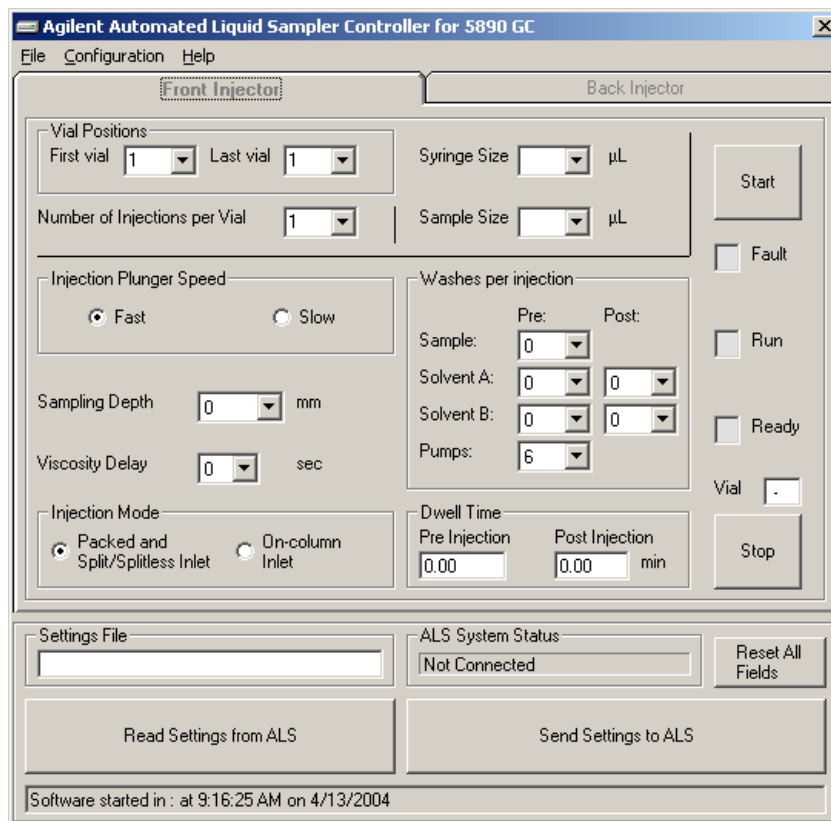

**Figure 37** 5890 ALS controller software main screen

After setting required parameters, select **Send Settings to ALS** to load the values into the G2912A Controller. For more information, see the online Help.

If the controller somehow becomes corrupted with bad parameters, it may be necessary to reset the controller to its factory defaults. To restore the G2912 Controller factory defaults, turn the controller power off, press and hold the [**Start**] and [**Stop**] buttons, turn the power on, hold the buttons in for five seconds and release the buttons.

See “[Using the ALS Controller](#)” on page 131 for information on using the [**Start**] and [**Stop**] buttons on the controller and 5890GC.

## Setting Injector Parameters on a 6890 GC

Press [**Front Injector**] or [**Back Injector**].

Scroll to the desired setpoint detailed below.

Enter a setpoint value, or turn the setpoint on or off.

FRONT INJECTOR	
Injection vol	1.0<
# Sample pumps	1
Viscosity delay	1
# Sample washes	1
# Solv A washes	1
# Solv B washes	0
Slow plunger	Off
Pre dwell time	0.10
Post dwell	0.10
Sampling offset	2.0
# Solv A pre wash	2
# Solv B pre wash	2

Injection volume—Sample volume to be injected. On a 6890N GC press [**Mode/Type**] to select. For a 6890N GC, the available volumes depend on the syringe size configured. See “[Configuring the injector on a 6890 GC](#)” on page 89.

- The selections represent 2%, 10%, 20%, 30%, 40%, and 50% of syringe size
- Turn the injection volume Off to disable the injector

On a 6890A or Plus GC enter a value from the volume unit column in [Table 14](#).

**Table 14** Injection volumes for a 6890A or Plus GCs

Syringe stop	Injection volume as percent of syringe size	
	Nanoliter adapter On	Nanoliter adapter Off
1	2%	10%
2	10%	20%
3	20%	30%
4	30%	40%
5	40%	50%
6	50%	Not available

**Number of sample pumps**—How many times (0–15) the syringe plunger is moved up and down with the needle in the sample to expel air bubbles and improve reproducibility.

**Viscosity delay**—How many seconds (0–7) the plunger pauses at the top of the pump and injection strokes. For viscous samples, the pause allows the sample to flow into the vacuum created in the syringe.

**Number of sample washes**—How many times (0–15) the syringe is rinsed with sample before the injection. The injector lowers the syringe needle into the sample vial, draws up sample, and empties it into one of the waste bottles. The amount of sample used for wash is set in the Solvent Saving injector configuration parameter defined on [page 90](#).

**Number of solvent A washes**—How many times (0–15) the syringe is rinsed with solvent from the solvent A (A, A2, A3) bottles.

**Number of solvent B washes**—How many times (0–15) the syringe is rinsed with solvent from the solvent B (B, B2, B3) bottles.

**Slow plunger**—The speed of the syringe plunger during injection. Enables you to reduce the average speed of the plunger and hold the syringe needle in the inlet for 4 seconds after the injection. Turning the setpoint On pushes at a rate of about 5  $\mu\text{L}/\text{sec}$  (with a 10  $\mu\text{L}$  syringe)—Off is about 20 times faster. The plunger speed during the pump and waste dispensing does not change.

**Dwell times**—How long, in minutes (0–1), the needle remains in the inlet before or after the injection.

**Sampling offset**—Enables variable sampling depth.



Solvent A prewash—How many times (0–15) the syringe is rinsed with solvent before loading the syringe.

Solvent B prewash—How many times (0–15) the syringe is rinsed with solvent before loading the syringe.

## Configuring the injector on a 6890 GC

Press **[Config] [Front Injector]** or **[Config] [Back Injector]** to display the parameters.

Scroll to the desired parameter detailed below.

CONFIG B INJ	
Back Tower	INJ1
Use A-A2, B-B2	
Solvent Saving	2.0µL
Syringe size	10.0
Nanoliter adapt	On
Tower fan	Off

Tower position—Injector cables are connected to either the INJ1 or INJ2 port on the GC. This setpoint indicates which tower is on which inlet. You do not have to move cables when you switch the towers, merely reconfigure the tower position. Use the **[Off]** button to toggle this location.

Syringe size—**6890N** only. Enter a syringe size between 1 and 100 µL.

Wash mode—**G2913** This is only displayed when the G2913A injector has a 1-vial turret installed. On a 6890N GC the turret solvent bottle positions are selected using the **[Mode/Type]** key:

Wash using A, B—Uses solvent bottle A if injector uses solvent A washes and solvent bottle B if injector uses solvent B washes.

Use A-A2, B-B2—Uses solvent bottles A and A2 if injector uses solvent A washes and solvent bottles B and B2 if injector uses solvent B washes. The injector alternates between both bottles.

Use A-A3, B-B3—Uses solvent bottles A, A2, and A3 if injector uses solvent A washes and solvent bottles B, B2, and B3 if injector uses solvent B washes. The injector alternates between all bottles.

For a 6890A or 6890 Plus GC, the wash mode is controlled by entering a value of:

- 1 for using solvent bottle A if injector uses solvent A washes and solvent bottle B if injector uses solvent B washes.
- 2 for using solvent bottles A and A2 if injector uses solvent A washes and solvent bottles B and B2 if injector uses solvent B washes. The injector alternates between both bottles.
- 3 for using solvent bottles A, A2, and A3 if injector uses solvent A washes and solvent bottles B, B2, and B3 if injector uses solvent B washes. The injector alternates between all bottles.

The G2913A injector always uses both WA waste bottles if a solvent A wash is used and both WB waste bottles if a solvent B wash is used.

Waste bottle mode—**G2613** This is only displayed when the G2613A injector has a 3-vial turret installed. On a 6890N GC the turret waste bottle positions are controlled using the **[Mode/Type]** key:

- Use both A and B alternates between the two waste bottles
- Use only A bottle uses waste bottle A only
- Use only B bottle uses waste bottle B only

For a 6890A or 6890 Plus GC these turret waste bottle positions are controlled by entering a value of:

- 0 for the A position only
- 1 for the B position only
- 2 to alternate between the two waste bottles

Solvent Saving—Use this option to vary the syringe wash amount from about 20% to 80% of syringe volume. This setting reduces the amount of solvent and sample consumed during each injection cycle. See “[Sample Carryover](#)” on page 79 for more information.

On a 6890N, the wash amount is selected using the **[Mode/Type]** key. This brings up a selection of actual wash volumes based on the volume of the syringe used.

For a 6890A or 6890 Plus, these settings are controlled by entering a setpoint value of:

- 0 to disable the solvent saving feature resulting in a wash volume equal to 80% of syringe volume.
- 1 for 50% of syringe volume wash
- 2 for 37% of syringe volume wash
- 3 for 25% of syringe volume wash

**Nanoliter adapter—6890 GC only** Use this option to vary the injection volumes available with your automatic liquid sampler. When On, injection volumes range from 2% through 50% of syringe volume. When Off, the volume range is 10% through 50%.

**Use B2 wash—G2613A** This is only displayed if you have the 3-vial turret installed in the G2613A injector. You can enable this option to use two 4 mL vials of solvent B, increasing the number of runs you can make before refilling solvent vials. Press the **[On]** button to enable B2 wash.

- Use the same solvent in position B and in position B2. (This option does not enable you to use a third solvent.)
- When using solvent A and solvent B, both waste bottles are required.
- Your maximum solvent capacity is 6 mL (2 mL each for solvent vials A, B, and B2).
- Configure each injector separately.

Note that the number of solvent B washes for each injection does not change. The injector simply alternates use between the two solvent B vials.

This mode allows the number of solvent B washes to be twice that of the solvent A washes.

**Tower fan**—Use the **[On]** or **[Off]** key to select fan usage.

In general, leave the fan On.

## Setting sample tray setpoints on a 6890 GC

The sample tray delivers sample vials to the front and rear injectors according to the defined sequence parameters. There are a separate set of sequence parameters for each injector. The sample tray delivers vials to the front injector before the rear injector. Stored sequences and bar code configurations can be used to tell the sample tray where to deliver and retrieve sample vials.

## 4 Controlling the Sampler

Enable Tray—turn On for a tray sequence, Off for sample bottles in the injector turret.

Enable bar code—turns the Bar Code Reader on or off.

Press [**Sample tray**] to access the sample tray and Bar Code Reader setpoints.

```
SAMPLE TRAY
Enable Tray      On
Enable bar code  Off
```

To edit the sample tray configuration setpoints, press [**Config**][**Sample Tray**].

```
CONFIG SAMPLE TRAY
Grip offset      Up
F inj offst     Cw
B inj offst     Ccw
Enable 3 of 9    On<
Enable 2 of 5    Off
Enable UPC code  Off
BCR position     3
```

[On] to use bar encoding, [Off] to disable

Bar Code Reader position on tray, always set to a value of 3

Grip offset—On a 6890N GC the grip offset is controlled using the [**Mode/Type**] key.

- Up—Select to have the gripper arm pickup height at a higher location.
- Default
- Down—Select to have the gripper arm pickup height at a lower location.

For a 6890A or 6890 Plus GC press **[Info]** to see the value to enter in to the setpoint to control the grip offset.

F (or B) inj offst—The Rotation offset for injector position on a 6890N GC is controlled using the **[Mode/Type]** key.

- Counterclockwise—Select to have the gripper arm meet the turret at a further counterclockwise position.
- Default
- Clockwise—Select to have the gripper arm meet the turret at a further clockwise position.

For a 6890A or 6890 Plus GC, press **[Info]** to see the value to enter in to the set point to control the rotation offset.

Press **[On]** or **[Off]** to control the following bar code setpoints.

Enable 3 of 9—the 3 of 9 code offers the greatest versatility for laboratory use. It can encode both letters and numbers, plus a few punctuation marks, and message length can be varied to suit both the amount of data to be encoded and the space available.

Enable 2 of 5—the 2 of 5 code is restricted to numbers but does allow variable message length.

Enable UPC code—the Universal Product Code (UPC) is probably the most well-known code in use today. UPC codes are numbers-only and have fixed message length.

BCR Position—Enter 3 as the BCR position.

For more information on the Bar Code Reader, see “[The Bar Code Reader](#)” on page 22, “[Procedure 7. Installing the G2615A Bar Code Reader](#)” on page 53, or its Operating Manual.

## Storing injector setpoints

After setting up injector setpoints, sample tray setpoints and Bar Code Reader configurations, store them in the 6890 GC as part of a method by following the procedures in your 6890 Series GC documentation.

## Setting Parameters on a 6850 Series GC

### To set injection parameters

- 1 Display this screen.

Status / Automation / Injector

The screenshot displays the 'Injector' configuration screen. At the top, it shows the title 'Injector', a timestamp '11:46:04', 'Last Sample 01', 'RUN.M', and 'Not Ready'. Below this, there are several parameter fields: 'Plunger Pumps' is set to 5, 'Sample Size' is 1.0 uL, and 'Viscosity Delay' is 0 sec. There is also a checkbox for 'Slow plunger'. At the bottom of the screen, there are buttons for 'Washes', 'Depth Offset', and 'Dwell Times'. A diagram of a syringe with a 10 uL volume is shown on the left side of the screen.

- 2 Enter:

**Plunger Pumps**—The number of times to pump the plunger with the needle in the sample to expel bubbles before drawing up the measured sample amount.

**Sample Size**—The amount to be injected. The choices depend on the syringe size specified during setup.

**Viscosity Delay**—The number of seconds the plunger pauses at the top of the pump and inject strokes. This time allows viscous samples to flow into the vacuum created by the plunger.

**Slow plunger**—Reduces the plunger speed during injection from normal (about 100  $\mu\text{L}/\text{s}$  with a 10  $\mu\text{L}$  syringe) to about 5  $\mu\text{L}/\text{s}$ .

## Wash parameters

1 Display this screen.

### Status / Automation / Injector / Washes

Washes		12:05:33	Last Sample 01	Default+	Not Ready
	Sample	Solvent A	Solvent B		
Pre Washes	<input type="text" value="0"/>	<input type="text" value="0"/>	<input type="text" value="0"/>		
		<input type="text" value="0"/>	<input type="text" value="0"/>	Post Washes	

2 The syringe can be washed with sample before drawing up the amount to be injected. It can also be washed with solvent both before (pre-washes) and after (post-washes) an injection. The order of events is:

- Wash syringe with solvent A Solvent-A-Pre-Washes times
- Wash syringe with solvent B Solvent-B-Pre-Washes times
- Rinse syringe with sample Sample-Pre-Washes times
- Draw up sample and make injection
- Wash syringe with solvent A Solvent-A-Post-Washes times
- Wash syringe with solvent B Solvent-B-Post-Washes times

3 Enter your choices, then press Esc to return to the previous screen.

## Needle depth (Sampling depth offset)

1 Display this screen.

### Status / Automation / Injector / Depth Offset

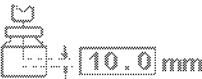
Depth Offset		12:05:40	Last Sample 01	Default+	Not Ready
<p>This parameter allows an offset in the the depth of the syringe needle in the sample vial. It can prevent particles being drawn up into the syringe.</p>	<input type="checkbox"/> Enable Offset				
					
	<input type="text" value="10.0"/> mm				



## 4 Controlling the Sampler

- 2 The default value, 0 mm, includes a small safety factor to avoid striking the bottom of the vial. This parameter can also be used to sample headspace instead of the liquid or solid sample.
- 3 Enter your choices, then press **ESC** to return to the previous screen.

### Dwell times

- 1 Display this screen.

#### Status / Automation / Injector / Dwell Times

<b>Dwell Times</b>		12:05:48	Last Sample 01	Default+	Not Ready
	<b>Pre Dwell</b> 0.00 min		<b>Post Dwell</b> 0.00 min		<input type="text"/>
<input type="text"/>	<input type="text"/>	<input type="text"/>	<input type="text"/>	<input type="text"/>	<input type="text"/>

- 2 Enter your choices. For most uses, both dwell times will be zero. This gives a fast injection with a minimum of boil-out from a hot needle.
- 3 Press **ESC** to return to the previous screen.

### To configure the injector

Depending on the GC firmware you have, the injector type and firmware, and the turret size of your injector, you can set various solvent parameters. To access these parameter settings:

- 1 Display this screen.



## Status / Setup / Automation / Injector

**Injector** 11:45:03 Last Sample 01 RUN.M Not Ready

**Syringe  $\mu\text{L}$**  **Solvent Bottle** **Solvent Volume**

5  
 10  
 other

Use A and B only  
 Use A, A2, A3 and B, B2, B3

Enable Saver Mode  
 Wash volume

More

Syringe settings      Solvent bottle usage settings      Solvent volume settings

This screen is an example of what might appear. The actual screen that appears will differ, based on your GC's configuration.

- 2 Set the parameters as necessary.
- 3 Press **Esc**.

The available settings can include the following:

### Syringe capacity

Enter the size of the syringe in microliters.

### Solvent bottle usage

Newer versions of the GC and injector firmware support extended solvent capacity, which is useful when you run large numbers of samples. If the method specifies solvent A or B usage, your solvent capacity can be extended:

Injector	Turret type (number of sample vial positions)	Extended solvent setting	Solvent bottle usage
G2613A	3-vial position	Use A, B, and B2	Uses solvent position A and alternates between B and B2
	8-vial position	—	—
G2913A	1-vial position	A, A2, A3, and B, B2, and B3	Alternates between the three A solvent bottles, and between the three B solvent bottles.
	8-vial position	—	—

Remember that the solvents you use (A and/or B) are set within the method. See “[Wash parameters](#)” on page 95.

### **Waste bottle usage**

For 3-sample turrets only. If the waste bottle control does not appear on the screen, press **More** to select that option. The positions containing bottles to use for waste (*A*, *B*, or *Alternate between A and B*).

### **Solvent volume**

Solvent volume allows you to conserve solvent by adjusting the amount used to wash the syringe.

Enable or disable saver mode and specify the amount of solvent to draw into the syringe on each wash. The default, if disabled, is 80% of the syringe volume.

### **Injector fan**

If the fan control does not appear on the screen, press **More** to select that option. Normally, leave the fan on to help cool the injector and keep your samples stable. Note that the fan will briefly turn off once per day for a short time. This extends fan life.

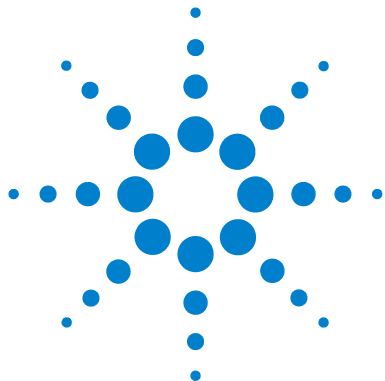

## 5 Syringes and Needles

Syringes	100
Selecting syringes	100
Inspecting a syringe	102
Installing a Syringe	103
Removing a Syringe	106
Replacing Syringe Needles	107

The 7683B injector uses syringes as the sample-handling device. This chapter describes their properties and uses.



## Syringes

### Selecting syringes

- 1 Select the syringe *type* based on the inlet you are using and the volume of sample you want to inject.

#### CAUTION

Failure to use an on-column syringe when injecting into an on-column inlet could damage the injector, syringe and column.

- 2 Select a syringe. Refer to your automatic liquid sampler operating documentation for available syringe sizes and corresponding injection volumes. Also refer to the Agilent catalog for consumables and supplies for part numbers and ordering information.
- 3 Select the appropriate syringe needle gauge (Table 15).

**Table 15** Needle gauge selection

Inlet	Column type	Needle gauge
Packed, split or splitless (including PTV)	Any Applicable	23 gauge or 23/26 gauge tapered
Cool on-column	250 $\mu\text{m}$ 320 $\mu\text{m}$ 530 $\mu\text{m}$	26/32 gauge tapered 26/32 gauge tapered 23/26 gauge tapered or 26 gauge

Use syringe needles with a conical tip. Do not use sharp-tipped needles. They tear the inlet septum and cause leaks. Also, a sharp-tipped needle tends to wipe off on the septum as it exits resulting in a large solvent tail on the chromatogram. See [Figure 38](#) and [Figure 39](#).

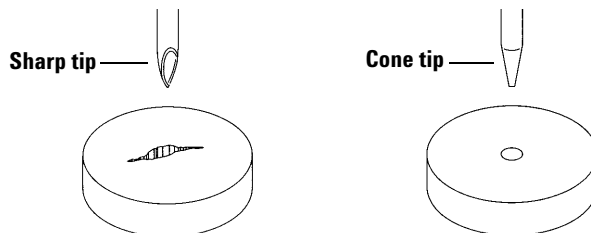

**Figure 38** Needle tips

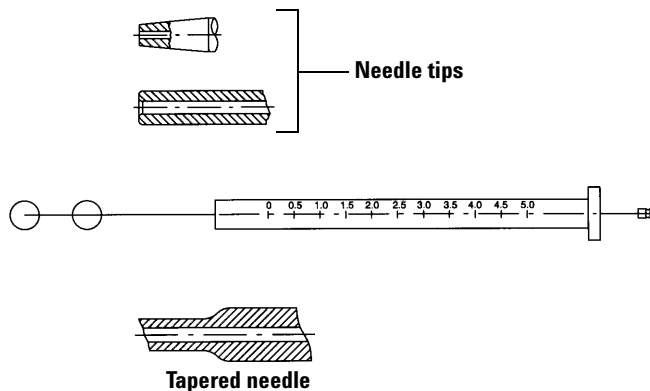
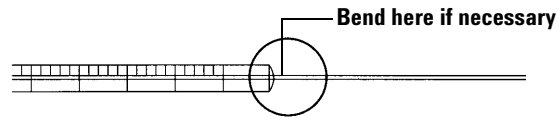

**Figure 39** Needle shapes

## Inspecting a syringe

Before installing a syringe:

- 1 Roll the syringe on the edge of a clean flat surface. If the tip of the needle moves in a circle, straighten the shaft by bending it slightly near where it connects to the syringe barrel and check it again. See [Figure 40](#).



**Figure 40** Inspecting the syringe

- 2 Check for a rough needle. The needle surface may have closely spaced concentric ridges that act like a miniature file and abrade pieces of the septum into the inlet or vial. The ridges are easy to see under 10X magnification.

If there are ridges, polish the needle by pulling it through a folded piece of fine emery paper between your finger and thumb until the ridges are gone. Be careful not to modify the tip of the syringe.

- 3 Check for a sticky plunger. Slide the plunger of the syringe up and down a few times. It should move smoothly without sticking or binding. If it is sticky, remove the plunger and clean it with solvent.

## Installing a Syringe

To install a syringe (Figure 41):

- 1 Open the injector door.
- 2 Slide the syringe carriage up (or down) until the syringe is accessible. See Figure 41.
- 3 Pass the syringe needle through the hole in the needle support foot.
- 4 Align the syringe barrel with the flange guide and syringe clip and press the syringe into place, keeping the needle in the hole of the needle support foot.
- 5 Close the syringe latch by swinging it clockwise.

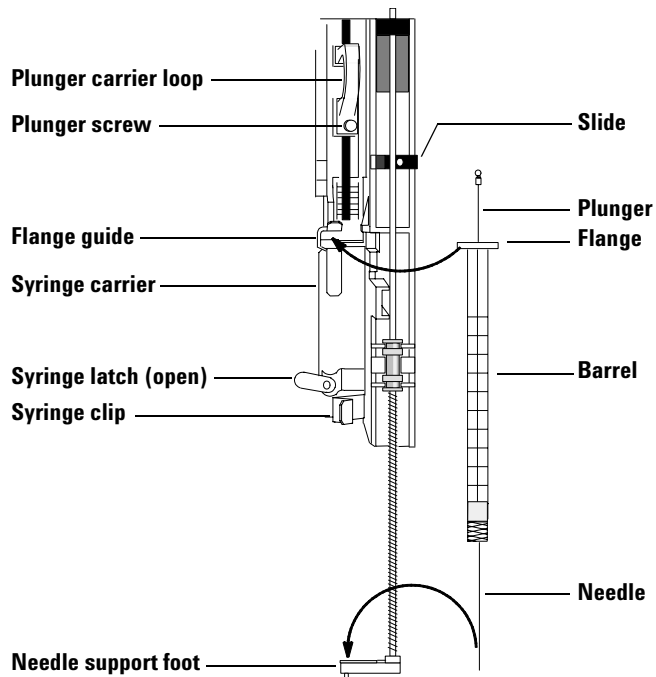

**Figure 41** Installing a syringe

- 6 Loosen plunger screw until the stop is reached.

## 5 Syringes and Needles

- 7 Move the plunger carrier loop down and tighten the plunger screw until it stops.
- 8 Move the plunger carrier loop up and down. If the syringe plunger does not move along with the carrier, repeat the previous steps. Be sure the plunger screw is tight.

### CAUTION

Repeating this movement can damage the syringe.

- 9 Check that the needle is aligned with the needle guide in the foot by moving the slide up and down. The needle should slide smoothly in the needle guide. See [Figure 42](#).

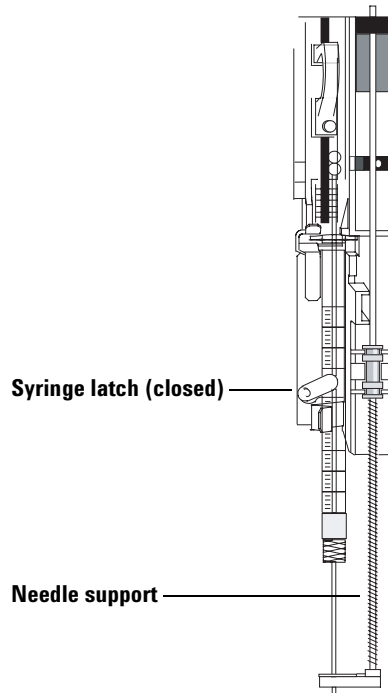

**Figure 42** Syringe carriage and needle support with syringe installed



**CAUTION**

Do not operate the injector without a syringe in place because the syringe latch may interfere with the motor if it is allowed to swing freely.

---

- 10** Pull down the syringe carriage until the needle support guide tip is near the top of the inlet septum nut.

The needle support guide should be nearly centered over the tapered hole in the septum retainer nut.

- 11** If the needle is not nearly centered over the septum retainer nut, check that the syringe is installed correctly in the syringe carrier, the syringe needle is straight, and the needle support assembly is properly installed.

## Removing a Syringe

- 1 Loosen the plunger screw and raise the plunger carrier loop off the syringe plunger.
- 2 Open the syringe latch.

### CAUTION

Be careful not to bend the syringe needle. Only pull the syringe out of the carriage until clear. The needle bends easily when still seated in the needle support guide.

---

- 3 Carefully lift the syringe flange out of the flange guide until clear, then lift the syringe needle out of the needle support guide.

## Replacing Syringe Needles

The stainless steel needles used for 250- $\mu\text{m}$  and 320- $\mu\text{m}$  injections must be inserted into a glass syringe barrel (the 5- $\mu\text{L}$  syringe barrel is part no. 5182-0836). Select the correct size needle for the column you will use.

Needles for 250- $\mu\text{m}$  injections (part no. 5182-0833, 3/pk) have silver-colored stops. Needles for 320- $\mu\text{m}$  injections (part no. 5182-0831, 3/pk) have gold-colored stops. See your Agilent catalog for consumables and supplies for a complete list of syringes and needles.

To insert a needle into a syringe barrel ([Figure 43](#)):

- 1 Unscrew the syringe barrel cap and remove the spring.
- 2 Make sure the needle has the Teflon<sup>®</sup> disk as shown in [Figure 43](#). If the syringe barrel does not have the Teflon<sup>®</sup> disk, use the instructions in the syringe box to wrap the needle yourself.
- 3 Slide the spring and the cap down over the needle.
- 4 Insert the needle into the syringe barrel.

## 5 Syringes and Needles

5 Screw the cap back on the syringe barrel.

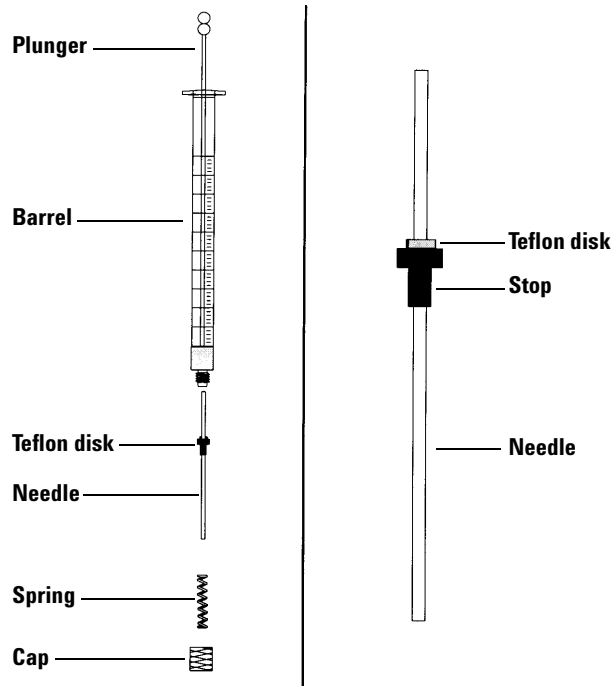

**Figure 43** Syringe parts

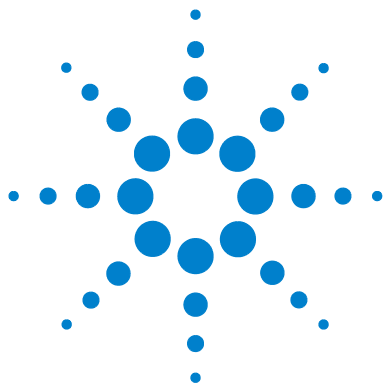

## 6 Vials and Bottles

Preparing Sample Vials	110
Selecting sample vials	110
Selecting vial septa	111
Filling sample vials	112
Labeling sample vials	112
Capping sample vials	113
Preparing Solvent and Waste Bottles	116
Selecting the bottles	116
Filling the solvent bottles	117
Preparing the waste bottles	117
Placing Vials and Bottles in the Sampler	118
If you do not use the optional 100-vial tray	119
If you use the optional 100-vial tray	120
Using Two Injectors (5890, 6890 only)	121
With a tray	121
Without a tray	121
How Many Sample Vials Can I Run?	122

This chapter describes sample vials, solvent bottles, and waste bottles, including how to place them in the tray or turret. It also discusses how to estimate the maximum number of samples that can be run before solvent bottles must be refilled or waste bottles must be emptied.



## Preparing Sample Vials

### Selecting sample vials

The 7683 Automatic Liquid Sampler injector and the tray use clear or amber glass sample vials with crimp caps, or Target® DP™ screw-cap vials. Use amber glass vials for light-sensitive samples. Refer to your Agilent catalog for consumables and supplies for acceptable vial types. Incompatible sample vials cause tray and turret errors.

Figure 44 shows the critical dimensions for sample vials and microvial inserts to be used with the 7683 Automatic Liquid Sampler. These dimensions do not make up a complete set of specifications.

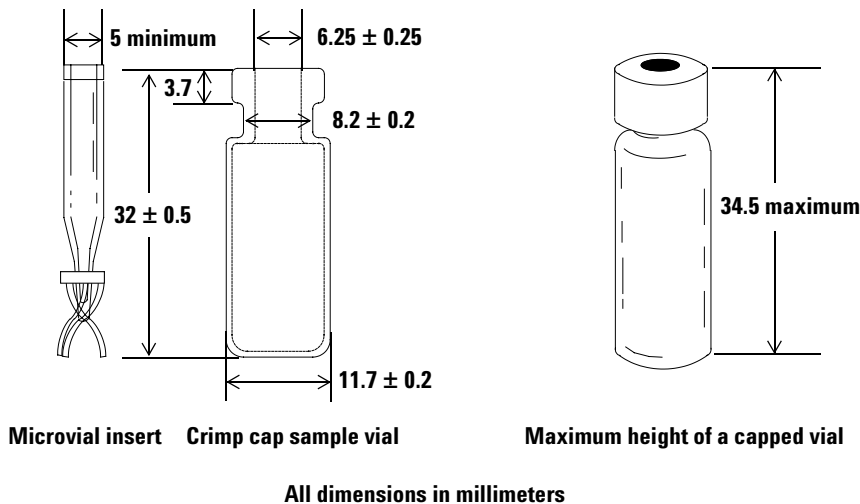

**Figure 44** Sample vial and microvial insert dimensions

## Selecting vial septa

There are two types of septa used with crimp caps and screw-on caps, each with different resealing characteristics and different resistance to solvents.

- One type is natural rubber formulation coated with Teflon on the sample side. This septum is suitable for samples with a pH range of 4.0 to 7.5. They are less resistant to solvents after puncture and are more easily cored than silicone rubber septa. Coring may deposit septum pieces in the vial and affect your chromatograms.
- Another is high-quality, low-extractable silicone rubber septa, coated with Teflon on one or both sides. They are more resistant to solvents after puncture and to coring by the needle.

Refer to your Agilent catalog for consumables and supplies for more information.

Figure 45 shows the diameter for vial cap apertures.

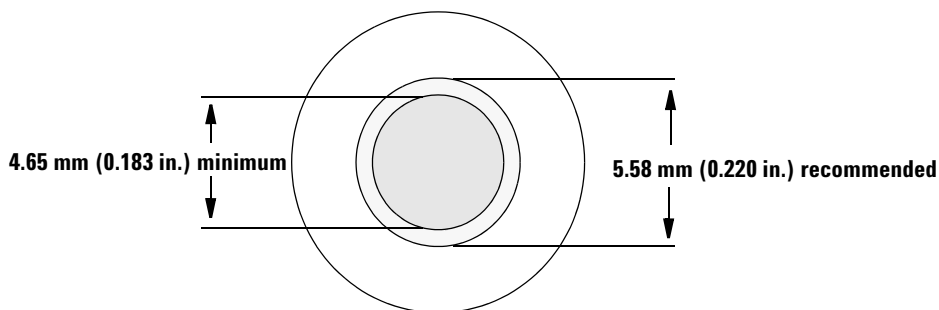

**Figure 45** Vial cap aperture specifications

## Labeling sample vials

Vials are available with a write-on spot for easy marking. If you choose to make and apply your own labels, Agilent Technologies recommends the positioning and maximum label thickness shown in [Figure 46](#).

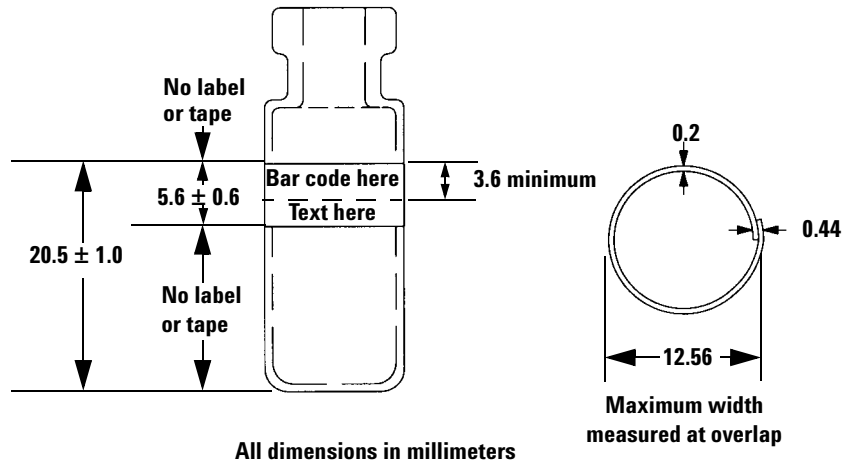

**Figure 46** Label dimensions

### CAUTION

Correct sample vial dimensions are critical for proper tray gripper operation. Vials and labels that do not meet these specifications may cause sampler errors. Service calls and repairs found to be due to vials and microvials that do not meet these specifications are not covered under warranty or the service contract.

## Filling sample vials

[Figure 47](#) shows the recommended fill volumes for sample vials of:

- 1 mL for the 2-mL vial
- 50  $\mu$ L for the 100- $\mu$ L vial

The air space in the vial is necessary to avoid forming a vacuum when sample is withdrawn. This could affect reproducibility.



**CAUTION**

Do not inject air into the vials to prevent this vacuum. This often damages the cap seal and may cause damaged syringe needles.

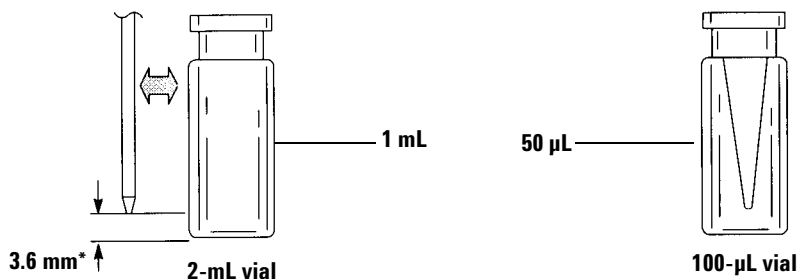

\* Needle position based on default sampling depth.

**Figure 47** Recommended fill volumes for sample vials

When developing your method, keep the following in mind:

- If you need to test a large amount of sample over repeated injections, divide the sample among several vials to obtain reliable results.
- When sample volume in the vial is low, contaminants from the previous sample injection or solvent washes may have a greater impact on the sample.

If you change suppliers, you may need to redevelop your method. Differing manufacturing practices for vial hardware sometimes cause variances in your results.

## Capping sample vials

When a tray is not installed, you may be able to use sample vials with diffusion caps, snap-on caps, or screw-on caps depending on your application. If a tray is used, sample vials should have crimp caps or screw caps installed. Snap caps are not recommended. See [Figure 48](#).

To install the airtight crimp caps:

- 1 Clean the inside surfaces of the crimper jaws.

- 2 Place the crimp cap over the top of the vial.
- 3 Lift the vial into the crimper. Squeeze the handle until it reaches the adjuster screw.

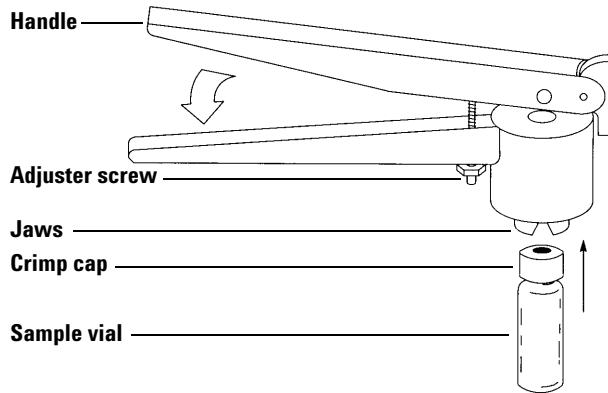

Figure 48 Crimping caps

Figure 49 shows acceptable and unacceptable vial caps.

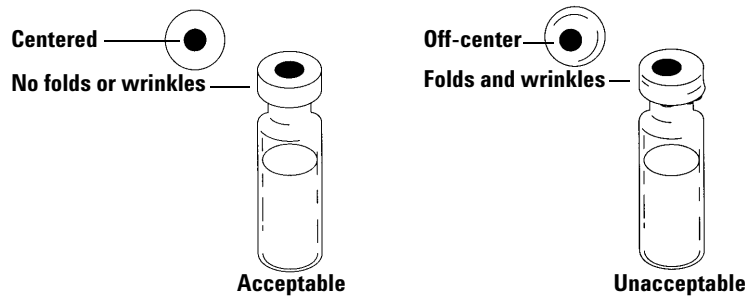

Figure 49 Acceptable and unacceptable caps

Check each vial for proper crimping:

- 1 Be sure there are no folds or wrinkles on the part of the cap that wraps under the neck of the vial. To remove folds or wrinkles, turn the vial about

- 10° and crimp it again. Adjust the crimper for a looser crimp by turning the adjusting screw clockwise.
- 2 Check that the cap cannot be turned by hand. If the cap is loose, adjust the crimper for a tighter crimp by turning the adjusting screw counterclockwise. Crimp the cap again.
  - 3 Be sure that each cap has a flat septum centered over the top of the vial.
    - If the septum is not flat, remove the cap, turn the crimper adjusting screw clockwise, and try again.
    - If the cap is not centered, remove the cap and make sure the new cap is flat on the top of the vial before you squeeze the crimper.

## Preparing Solvent and Waste Bottles

The solvent bottles hold solvent for rinsing the syringe between injections. The injector dispenses the solvent washes and sample washes into waste bottles. The number of samples that can be analyzed may be limited by the wash or waste bottle capacity shown in [Figure 51](#) and [Figure 52](#).

### Selecting the bottles

Solvent and waste bottles can be closed with either diffusion caps (a plastic cap with a hole; it retards evaporation while letting the needle enter freely) or septa. Agilent Technologies recommends diffusion caps (See [Figure 50](#)) over septa for two reasons:

- The diffusion cap allows multiple entrances into a bottle without contaminating the liquid inside the bottle with small pieces of septum material.
- For common solvents, the rate of diffusion out of the bottle is less with a diffusion cap than with a septum that has been punctured with a standard syringe needle.

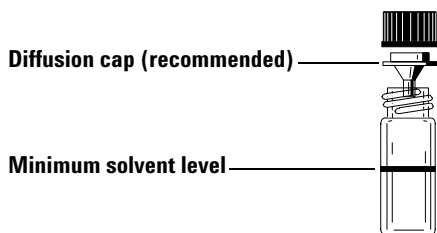

**Figure 50** Four milliliter bottle used for solvent or waste

## Filling the solvent bottles

Rinse and fill each solvent bottle with 4 mL of fresh solvent. The liquid level will be near the shoulder of the bottle. Good laboratory practice dictates using no more than 2.0 mL of the 4 mL solvent for syringe washes. The needle tip draws solvent 18.5 mm from the bottom of the vial. See [Figure 51](#).

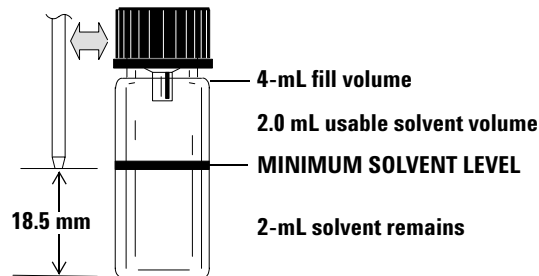

**Figure 51** Needle tip position when withdrawing solvent

## Preparing the waste bottles

Empty and rinse each waste bottle after each multiple vial run. The syringe can discard about 4 mL of waste into the waste bottle. See [Figure 52](#).

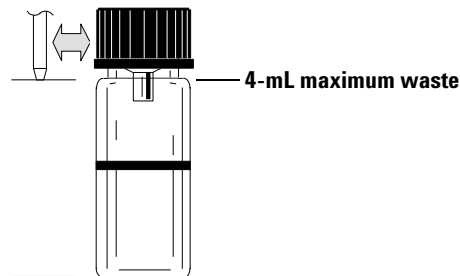

**Figure 52** Needle tip position when discharging waste

## Placing Vials and Bottles in the Sampler

Two turrets are provided with the G2913A injector ([Figure 53](#)).

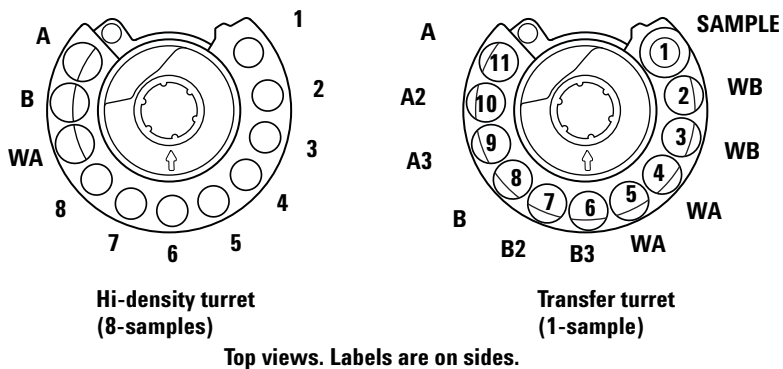

**Figure 53** G2913 Injector turrets

### CAUTION

We strongly recommend that *all* waste positions in *all* turrets contain bottles at *all* times, regardless of which ones are actually used in the current configuration. This protects against accidental discharge of solvent into the turret body, which could damage it.

The labeled positions for the Hi-density turret are defined in [Table 16](#). See [Table 17](#) for the positions in the Transfer turret.

**Table 16** Hi-density turret labels

Label	Bottle/Vial
A	Solvent bottle A
B	Solvent bottle B
WA	Waste bottle
1 through 8	Sample vials

**Table 17** Transfer turret labels

Position	Label	Bottle/Vial
1	SAMPLE	Sample vial transfer position
2	WB	Waste bottle B
3	WB	Waste bottle B
4	WA	Waste bottle A
5	WA	Waste bottle A
6	B3	Solvent bottle B3
7	B2	Solvent bottle B2
8	B	Solvent bottle B
9	A3	Solvent bottle A3
10	A2	Solvent bottle A2
11	A	Solvent bottle A

### If you do not use the optional 100-vial tray

You can place up to eight vials, a solvent A, a solvent B, and a waste bottle in the 8-sample injector turret. If you use the 1-sample transfer turret, you can only load 1 sample vial but the solvent and waste bottle capacity increases to 10. The transfer turret is generally used only with the tray. See [Figure 53](#).

### If you use the optional 100-vial tray

You must use the transfer (1-sample) turret. Place up to 100 samples in the four tray quadrants, according to the programmed sequence. Figure 54 shows tray loading for a sequence that uses tray positions 6 through 21.

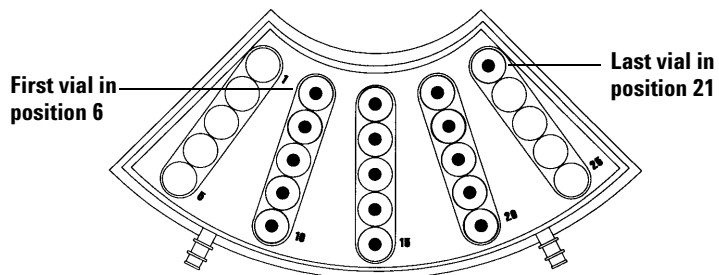

**Figure 54** Loading tray positions



## Using Two Injectors (5890, 6890 only)

With two injectors mounted on the GC, you can use the front injector or the back injector or both injectors simultaneously.

Two-injector configurations have the following characteristics:

- The system sends one injector ready signal to the GC when both injectors are ready and one start signal at the beginning of the injection stroke.
- The two injectors inject simultaneously.

### With a tray

Set run parameters for each injector in the sequence. When you set up the run parameters, you must identify which data channel is for which injector on a 6890 GC.

- When using a 6890 Series GC for sampler control, you assign the channel when you set up the sequence.
- When using the Agilent ChemStation for sampler control, you assign the channel when defining the instruments.

When both injectors have samples, they begin the injection cycle together, including any sample washes. After they have completed the specified sampling steps, they inject the samples. After the injection, both injectors go through the solvent wash cycle. When both injectors are done, the tray picks up the sample vial from the front injector and returns it to its original position on the tray, then picks up the vial from the back injector and returns it to its original position.

### Without a tray

The injectors go through the same motions as with a tray. The injectors inject samples from position 1 first, followed by samples from the remaining sample vial positions. If the two injectors do not have the same number of samples, the injector that completes its sequence first remains idle while the other finishes.

## How Many Sample Vials Can I Run?

The number of sample vials that you can run at one time is determined by the following parameters for your application:

- The number of sample injections per sample vial.
- The syringe size used: 1  $\mu\text{L}$ , 5  $\mu\text{L}$ , 10  $\mu\text{L}$ , 25  $\mu\text{L}$ , 50  $\mu\text{L}$ , or 100  $\mu\text{L}$ .
- The syringe wash volume (see [Table 18](#))
- The number of solvent washes (both pre- and post-injection) required from each solvent bottle.
- The number of sample washes and solvent washes per sample injection that the injector discards into each waste bottle.
- Number of waste bottles.

**Table 18** Syringe wash volumes

Syringe Size $\mu\text{L}$	80% syringe volume $\mu\text{L}$	40% syringe volume $\mu\text{L}$	30% syringe volume $\mu\text{L}$	20% syringe volume $\mu\text{L}$
1	0.8	0.4	0.3	0.2
5	4	2	1.5	1
10	8	4	3	2
25	20	10	7.5	5
50	40	20	15	10
100	80	40	30	20

## Solvent bottle equation (G2913 A injector)

### CAUTION

The number of sample vials given by these equations are estimates. Solvent characteristics such as evaporation rate and surface tension may affect the capacity of the bottles.

This equation estimates the maximum number of sample vials you can run from one solvent bottle.

Maximum number of sample vials per solvent bottle

$$= \frac{2000}{V_W \times N_{SI} \times N_{SW}}$$

where:

$V_W$  = Volume of Wash in  $\mu\text{L}$  taken from [Table 18](#)

$N_{SI}$  = Number of sample injections taken from each sample vial

$N_{SW}$  = Number of Solvent washes (pre and post) per sample injected

## Waste bottle equation

This equation estimates the maximum number of sample vials you can run from one waste type.

Maximum number of sample vials per waste bottles used (WA or WB)

$$= \frac{V_{Waste}}{V_{Wash} \times N_{SI} \times N_{SS}}$$

where:

$V_{Waste}$  = Volume of waste bottles used (WA or WB) in  $\mu\text{L}$ . Use 4000 for the 8-sample turret and 8000 for the 1-sample turret

$V_{Wash}$  = Volume of wash in  $\mu\text{L}$  taken from [Table 18](#)

$N_{SI}$  = Number of sample injections taken from each sample vial

$N_{SS}$  = Total number of pre- and post-solvent A or solvent B washes and sample washes per sample injected. When using both solvent A and B, the sample wash is divided evenly between all four waste bottles in the 1-sample turret

### Example

A tray is installed with a 1-sample turret in the injector. Your application parameters are:

- Two injections per vial
- Three washes from solvent bottle A
- Two washes from solvent bottle B
- Two sample washes
- 10- $\mu$ L syringe
- 80% wash volume (default)

1 Substitute the parameters of your application into the solvent bottle equation:

#### For Solvent A

$V_W = 8$  from [Table 18](#)

$N_{SI} = 2$

$N_{SW} = 3$

Maximum number of sample vials per solvent bottle

$$= \frac{2000}{8 \times 2 \times 3} = 41$$

#### For Solvent B

$V_W = 8$  from [Table 18](#)

$N_{SI} = 2$

$N_{SW} = 2$

Maximum number of sample vials per solvent bottle

$$= \frac{2000}{8 \times 2 \times 2} = 62$$

- 2 Substitute the parameters of your application into the waste bottle equation:

**For Waste A**

$V_{\text{Waste}}$  = Use 8000 for the 1-sample turret

$V_{\text{Wash}}$  = 8 from [Table 18](#)

$N_{\text{SI}}$  = 2

$N_{\text{SS}}$  = 3 (solvent A washes) + 1 (Sample wash) = 4

Maximum number of sample vials per waste bottles used (WA)

$$= \frac{8000}{8 \times 2 \times 4} = 125$$

**For Waste B**

$V_{\text{Waste}}$  = Use 8000 for the 1-sample turret

$V_{\text{Wash}}$  = 8 from [Table 12](#)

$N_{\text{SI}}$  = 2

$N_{\text{SS}}$  = 2 (solvent B washes) + 1 (sample wash) = 3

Maximum number of sample vials per waste bottles used (WB)

$$= \frac{8000}{8 \times 2 \times 3} = 166$$

- 3 Analyze the results keeping the following in mind:
- The 1-sample turret has 2 waste A bottles and 2 waste B bottles. If solvent A is used, both waste A bottles must be used. If solvent B is used, both waste B bottles must be used.
  - Sample washes are evenly distributed to all waste bottles used.
  - The injector can be configured to use 1, 2, or 3 bottles of solvent A or solvent B or both.
  - [Tables 19](#) and [20](#) summarize the results.

**Table 19** For Solvent A and Waste A bottles

Total number of waste or solvent bottles	Sample vials/Waste bottles	Sample vials/Solvent vial
1	NA	41
2	100	84
3	NA	100

**Table 20** For Solvent B and Waste B bottles

Total number of waste or solvent bottles	Sample vials/Waste bottles	Sample vials/Solvent vial
1	NA	62
2	100	100
3	NA	100

Using a single solvent bottle of each type, all four waste bottles must be used; 41 vials can be run. Using two solvent A bottles and two solvent B bottles, 84 vials can be run. If you use three solvent A bottles and three solvent B bottles, you can run 100 vials which is the tray capacity limit.

**CAUTION**

We strongly recommend that *all* waste positions in *all* turrets contain bottles at *all* times, regardless of which ones are actually used in the current configuration. This protects against accidental discharge of solvent into the turret body, which could damage it.

## Reduced solvent and sample usage

Solvent and sample washes by default use 80% of the syringe capacity. Solvent and sample can be conserved by reducing this volume. This is done by configuring each injector's solvent saving setting. This feature is not available when using the 5890 GC.

### CAUTION

Teflon-tipped syringes must be used to lubricate the barrel wall. Standard syringes, will fail quickly with limited lubrication.

---

The solvent wash can be set to use less than the usual 80%. This modifies the solvent wash process as follows:

- 1 The syringe draws in solvent to the percent specified, which can be as little as 20% of the syringe size.
- 2 The syringe and needle rise out of the solvent bottle.
- 3 The plunger rises to the 80% mark, rinsing the syringe barrel with solvent, followed by air.
- 4 The solvent and air are discharged into a waste bottle.

Confirm that sample carryover (see "[Sample Carryover](#)" on page 79) is not a problem with the reduced solvent washes.

## **6 Vials and Bottles**



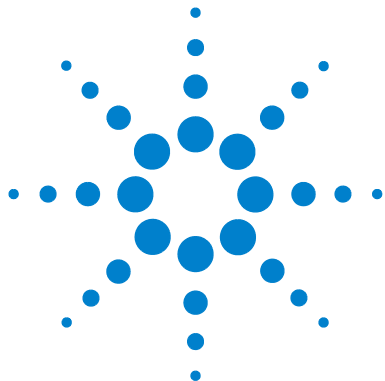

## 7 Running Samples

Running a Sample	130
Injection volume	130
Using the ALS Controller	131
Sampler response to interruptions	132
Restarting an interrupted sequence	132
Running a Priority Sample	134

This chapter describes the process for running one or more samples.



## Running a Sample

### WARNING

When running a sample, keep your hands away from the syringe needle. The needle is sharp and may contain hazardous chemicals.

To operate your automatic liquid sampler:

- 1 Install a clean syringe. See [“Installing a Syringe”](#) on page 103.
- 2 Fill the solvent bottles. See [“Preparing Solvent and Waste Bottles”](#) on page 116.
- 3 Place the solvent and waste bottles in the turret. See [“Placing Vials and Bottles in the Sampler”](#) on page 118.
- 4 Load the sample vials into the turret or the tray. See [“Preparing Sample Vials”](#) on page 110.
- 5 Prepare the GC sequence. See your GC or ChemStation documents.
- 6 Run the sequence by pressing the start button on the GC. On a 5890 GC you may optionally press the start button on the ALS controller. When the GC is ready, the ALS begins the injections.

## Injection volume

The injection volume depends on the sample size and the syringe size.

- Syringe size may be 1  $\mu\text{L}$ , 5  $\mu\text{L}$ , 10  $\mu\text{L}$ , 25  $\mu\text{L}$ , 50  $\mu\text{L}$ , or 100  $\mu\text{L}$ .
- Sample size may be 2%, 10%, 20%, 30%, 40%, or 50% of the syringe size.

After syringe size is selected, sample sizes are shown in microliters ([Table 21](#)).

**Table 21** Syringe and sample sizes

Syringe size, $\mu\text{L}$	Available sample sizes, $\mu\text{L}$					
	2%*	10%	20%	30%	40%	50%
1	0.02	0.1	0.2	0.3	0.4	0.5
5	0.1	0.5	1.0	1.5	2.0	2.5
10	0.2	1.0	2.0	3.0	4.0	5.0
25	0.5	2.5	5.0	7.5	10.0	12.5
50	1.0	5.0	10	15	20	25
100	2.0	10	20	30	40	50

\* Nanoliter adapt must be set to on for 6890 GC.

## Using the ALS Controller

When the ALS is on a 5890 GC:

- Pressing [**Start**] on the GC or controller begins the GC method. When the GC is ready, the ALS controller begins the sequence programmed in the ALS controller using the Agilent Automated Liquid Sampler Controller for 5890 GC software starting with the first sample vial in the range.
- Pressing [**Stop**] on the 5890 GC aborts the GC run, but does not stop the ALS controller sequence. When the GC enters the ready state the ALS controller continues with the next sample in its sequence. To stop the ALS controller sequence you must press the [**Stop**] button on the front of the controller.
- Pressing [**Stop**] on the ALS controller stops the sequence programmed into the controller. This action does not stop the GC run. Pressing [**Start**] on either the GC or ALS controller restarts the ALS controller vial sequence from the first sample.

When the ALS controller is on a 6890A GC:

- [**Start**] on the G2912A ALS controller is disabled.
- Pressing [**Start**] on the 6890A GC starts the sequence.
- Pressing [**Stop**] on the G2912A ALS controller stops the ALS controller sequence, and if the GC is waiting for a signal from the controller to start a run, an error message is displayed on the GC. To resume the sequence, see the following section on "[Restarting an interrupted sequence](#)" on page 132.

### Interrupting A Run Or Sequence

The following events interrupt a run:

- Power failures—The power to the GC or controlling device fails.
- Stop commands—[**Stop**] on the GC or 5890 ALS controller [**Stop**] is pressed, or the Stop Run/Abort option is selected from the Agilent ChemStation.
- Safety or operator faults—The sampler recognizes these fault(s):
  - The injector door was opened
  - Turret error
  - Plunger error
  - Tray arm axis error
  - The injector was moved on the GC during injection
  - The tray failed to deliver a vial

#### Sampler response to interruptions

If the interruption was caused by a problem that the sampler recognizes, a message appears on the 6890N, or 6850 GC or Agilent ChemStation. The 5890, 6890A, and 6890 Plus GCs do not display sampler messages. For more information, see "[Error Messages](#)" on page 162.

- Power failure—Aborts the run. Restart the sequence (see below).
- Stop commands—Interrupts the run. Restart the sequence (see below).
- Safety or operator faults—Aborts the run. Restart the sequence (see below).

Pressing the stop button on the 5890 ALS controller aborts the sampler sequence but does not stop the 5890 GC run. To abort the run you must use the GC stop button.

#### Restarting an interrupted sequence

To restart an aborted sequence from the point of interruption:

- 1 Resolve the problem that caused the interruption.
- 2 Identify the last sample vial that was run successfully. (Check the vial number of the last successful chromatogram.)
- 3 Assign the first sample vial run to be the vial number after the last successful one.

- 4 Start the revised sequence from your controlling device. (The Agilent ChemStation allows you to run a partial sequence to keep the original sample numbers.)

Following an interrupted sequence, the tray will attempt to return all vials to their proper tray position before beginning or resuming the sequence. Occasionally, you may need to manually return the vial to the tray before the sequence will start.

### Running a Priority Sample

Priority samples are for 6890 GCs only.

If the Use priority parameter is on in your GC sequence, the 7683 ALS tray checks for a vial in position 100 before loading a new vial into the injector turret. If it finds a vial there, it loads that sample vial into the turret and runs it according to the method you assigned for priority samples.

When the priority sample run is completed, it returns the priority sample vial to tray position 99, therefore keep this location empty when using this feature. The tray gripper again checks vial position 100 and, if there is no vial there, continues your original sequence from where it was interrupted. For more information on how to program priority sequences, see your 6890 GC documentation.

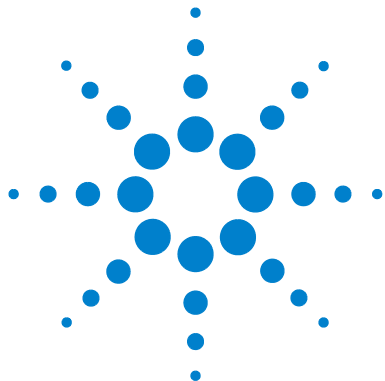

## Part 3:

# Maintenance and Troubleshooting

Maintenance	137
Periodic Maintenance	138
Adapting For Cool On-Column Injection	139
Installing a Syringe	141
Removing a Syringe	144
Replacing Syringe Needles	145
Changing the Turret	147
Align Mode	150
Replacing the Needle Support Assembly on the G2913A Injector	153
Replacing the Needle Guide in the Needle Support Foot	157
Replacing Power Fuses in the G2912A ALS Controller	158
Faults and Errors	159
Faults	160
Error Messages	162
Troubleshooting	167
Symptom: Variability	168
Symptom: Contamination or Ghost Peaks	170
Symptom: Smaller or Larger Peaks Than Expected	171
Symptom: Sample Carryover	173
Symptom: No Signal/No Peaks	174
Correcting Syringe Problems	175
Correcting Sample Vial Delivery Problems	176
Special Topics	177
Controlling Sample Vial Temperatures	178
Cool On-Column Injection	183
Suggestions for Packed Inlets with 530- $\mu$ m Columns	184



Replacement Parts [185](#)

G2912A — 7683B ALS Controller for 5890 Series II and  
6890A GCs [186](#)

G2913A — 7683B Injector Module [188](#)

G2614A — 7683 ALS Tray [190](#)

G2916A — 7683 ALS Tray for 5890 Series II GCs [191](#)

Miscellaneous Parts [192](#)



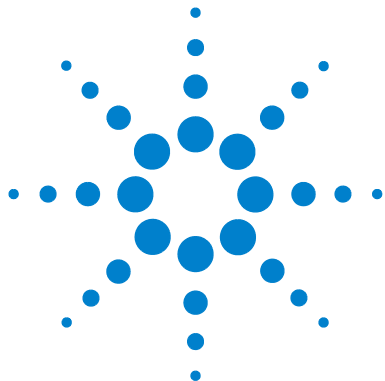

## 8 Maintenance

Periodic Maintenance	138
Adapting For Cool On-Column Injection	139
Installing a Syringe	141
Removing a Syringe	144
Replacing Syringe Needles	145
Changing the Turret	147
Align Mode	150
Replacing the Needle Support Assembly on the G2913A Injector	153
Replacing the Needle Guide in the Needle Support Foot	157
Replacing Power Fuses in the G2912A ALS Controller	158

The information in this chapter will assist you in keeping the sampler running smoothly.



## Periodic Maintenance

This section contains some suggestions for ensuring good performance of your 7683. The maintenance interval varies with the use of the instrument.

### CAUTION

Do not use any lubricants on the 7683 Automatic Liquid Sampler. They may affect the chemical performance of the GC and damage the instrument.

---

### CAUTION

When cleaning the instrument, as described below, use a damp (not wet!) towel. Do not use chemical cleaners.

---

On an occasional basis:

- ✓ Clean the surface of the tray arm, gripper, gripper jaws, and tray quadrants.
- ✓ Clean the needle guide and nearby surfaces of the injector. Dust and dirt accumulate in these areas and can be picked up by the syringe needle and carried into the inlet.
- ✓ Clean the surface of the injector. Vacuum off any dust that builds up around the vents.
- ✓ Make sure the injector mounting post is tight.
- ✓ Make sure the tray mounting screws are tight.
- ✓ Make sure the knurled nut on the top of the turret is tight.
- ✓ Be sure all the cables are securely attached.

## Adapting For Cool On-Column Injection

The 7683B injectors can inject samples directly onto 250- $\mu\text{m}$ , 320- $\mu\text{m}$ , and 530- $\mu\text{m}$  columns in GCs with a cool-on-column inlet.

To adapt the injector and GC for cool on-column use, follow these steps:

- 1 Select the on-column syringe needed for the column size. See your Agilent catalog for consumables and supplies, your GC operating documentation, and the Agilent web site ([www.agilent.com/chem](http://www.agilent.com/chem)) for a list of parts.
- 2 Prepare the GC inlet. (See your GC operating documentation for instructions).
  - Check your needle to column size.
  - Verify that the insert matches the needle size.
  - If necessary, replace the septum.
- 3 Verify that the correct needle support assembly ([Figure 55](#)) is installed in the injector. Replace if necessary. See [“Replacing the Needle Support Assembly on the G2913A Injector”](#) on page 153.

For a list of other consumables needed to perform these injections, see your GC operating documentation.

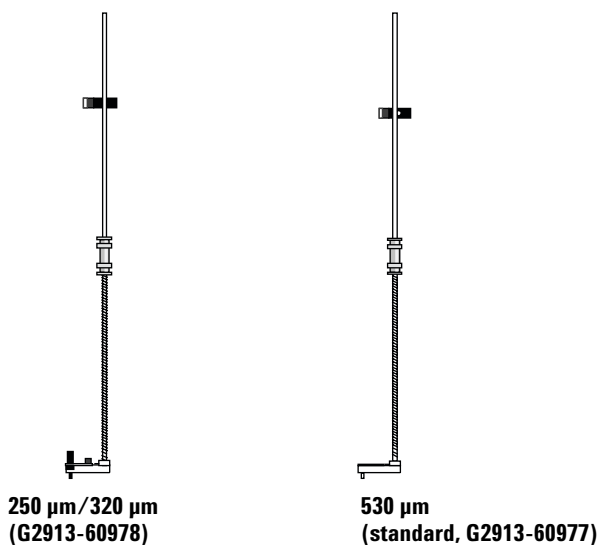

**Figure 55** Needle support assemblies

## 8 Maintenance

- 4 If necessary, reinstall the injector onto the GC.
- 5 Install the syringe. See [“Installing a Syringe”](#) on page 103.
- 6 Rotate the turret clockwise until it stops, then verify the installation by manually sliding the syringe carriage down until the needle enters the inlet.

## Installing a Syringe

To install a syringe (Figure 56):

- 1 Open the injector door.
- 2 Slide the syringe carriage up (or down) until the syringe is accessible. See Figure 56.
- 3 Pass the syringe needle through the hole in the needle support foot.
- 4 Align the syringe barrel with the flange guide and syringe clip and press the syringe into place, keeping the needle in the hole of the needle support foot.
- 5 Close the syringe latch by swinging it clockwise.

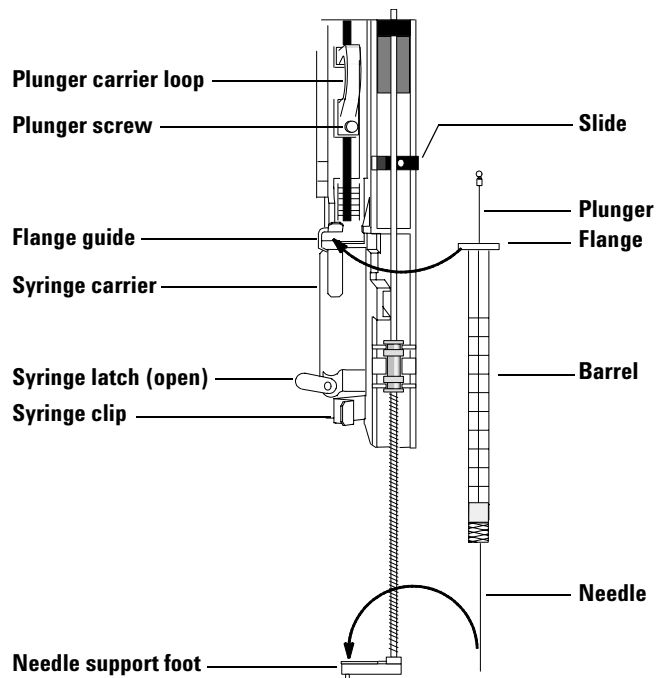

**Figure 56** Installing a syringe

- 6 Move the plunger carrier loop down and tighten the plunger screw.

- 7 Move the plunger carrier loop up and down. If the syringe plunger does not move along with the carrier, repeat the previous steps. Be sure the plunger screw is tight.
- 8 Check that the needle is aligned with the needle guide in the foot by moving the slide up and down. The needle should slide smoothly in the needle guide. See [Figure 57](#).

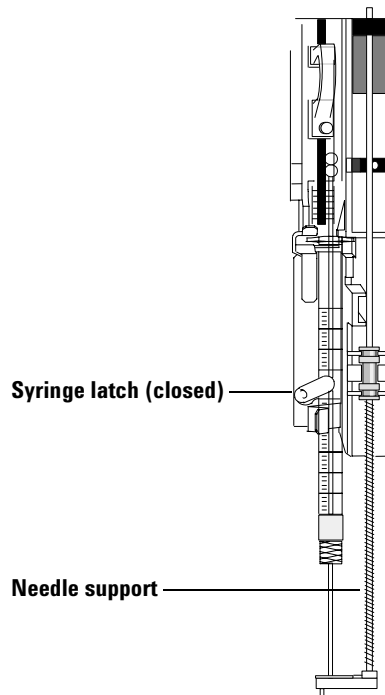

**Figure 57** Syringe carriage and needle support with syringe installed

### CAUTION

Do not operate the injector without a syringe in place because the syringe latch may interfere with the motor if it is allowed to swing freely.

- 9 Pull down the syringe carriage until the needle support guide tip is near the top of the inlet septum nut.

The needle support guide should be centered over the hole in the septum retainer nut. Make sure the needle will hit the septum without rubbing on the nut.

- 10** If the needle is not centered over the septum retainer nut, check that the syringe is installed correctly in the syringe carrier, the syringe needle is straight, and the needle support assembly is properly installed.

## Removing a Syringe

- 1 Loosen the plunger screw and raise the plunger carrier loop off the syringe plunger.
- 2 Open the syringe latch.

### CAUTION

Be careful not to bend the syringe needle. Only pull the syringe out of the carriage until clear. The needle bends easily when still seated in the needle support guide.

---

- 3 Carefully lift the syringe flange out of the flange guide until clear, then lift the syringe needle out of the needle support guide.



## Replacing Syringe Needles

The stainless steel needles used for 250- $\mu$ m and 320- $\mu$ m injections must be inserted into a glass syringe barrel (the 5- $\mu$ L syringe barrel is part no. 5182-0836). Select the correct size needle for the column you will use.

Needles for 250- $\mu$ m injections (part no. 5182-0833, 3/pk) have silver-colored stops. Needles for 320- $\mu$ m injections (part no. 5182-0831, 3/pk) have gold-colored stops. See your Agilent catalog for consumables and supplies for a complete list of syringes and needles.

To insert a needle into a syringe barrel ([Figure 58](#)):

- 1 Unscrew the syringe barrel cap and remove the spring.
- 2 Make sure the needle has the Teflon disk as shown in [Figure 58](#). If the syringe barrel does not have the Teflon disk, use the instructions in the syringe box to wrap the needle yourself.
- 3 Slide the spring and the cap down over the needle.
- 4 Insert the needle into the syringe barrel.

5 Screw the cap back on the syringe barrel.

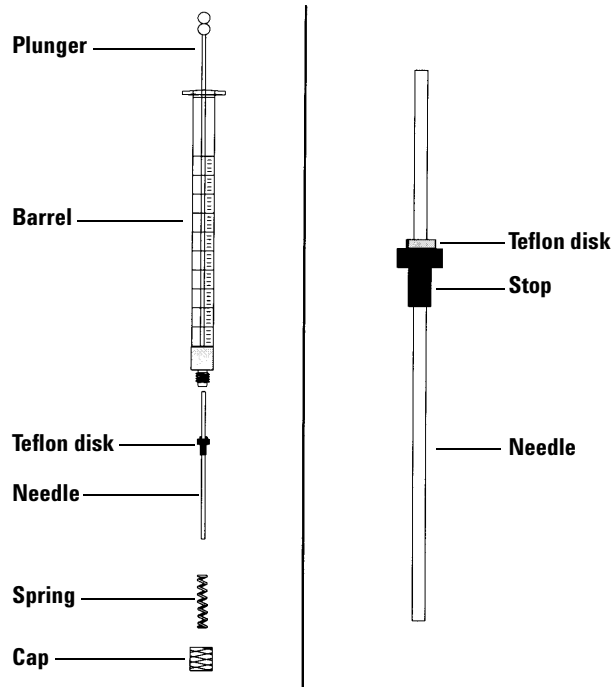
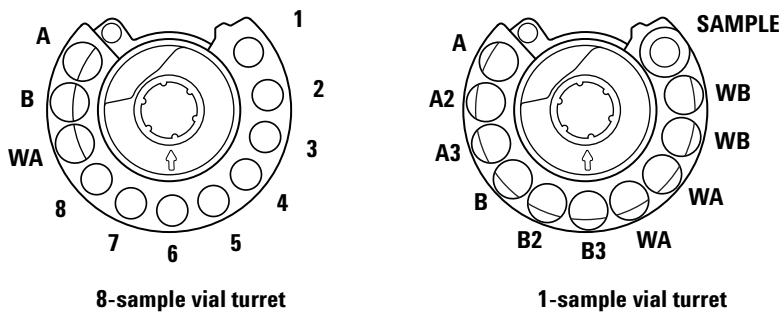

Figure 58 Syringe parts

## Changing the Turret

Two turrets are provided with the G2913A injector ([Figure 59](#)).



Top views. Labels are on turret sides.

**Figure 59** Injector turrets

The labeled positions are defined in [Table 22](#) and [Table 23](#).

**Table 22** The 8-sample vial turret

Name	Position	Meaning
A	11	Solvent bottle A
B	10	Solvent bottle B
WA	9	Waste bottle
1 through 8	1 through 8	Sample vials

**Table 23** The 1-sample vial turret

Name	Position	Meaning
SAMPLE	1	Sample vial transfer position
WB	2	Waste bottle B
WB	3	Waste bottle B
WA	4	Waste bottle A
WA	5	Waste bottle A
B3	6	Solvent bottle B3
B2	7	Solvent bottle B2
B	8	Solvent bottle B
A3	9	Solvent bottle A3
A2	10	Solvent bottle A2
A	11	Solvent bottle A

If you need to change your turret, use the following instructions for proper replacement.

**1** For a 5890/6890 GC with a tray:

- If you are changing from the 1-sample transfer turret to the 8-sample turret, disable the tray.
- If you are changing from the 8-sample turret to the 1-sample transfer turret, enable the tray.

The 5890 Series II GC uses a software program run on a PC connected to the controller to configure the tray. Run the program, select **Configuration**, and either *check* (to enable) or *uncheck* (to disable) the tray. Select **Send Settings to ALS** to download the new setting to the controller.

All 6890 GCs disable the tray using the GC keypad.

**2** Open the injector door. Unscrew and remove the knurled nut from the top of the turret.

- 3 Rotate the turret so that the open section faces the back of the tower and the arrow on top of the turret points directly back. Push the stripper arm toward the back, then lift the front of the turret so that it clears the center shaft. Remove the turret. See [Figure 60](#).

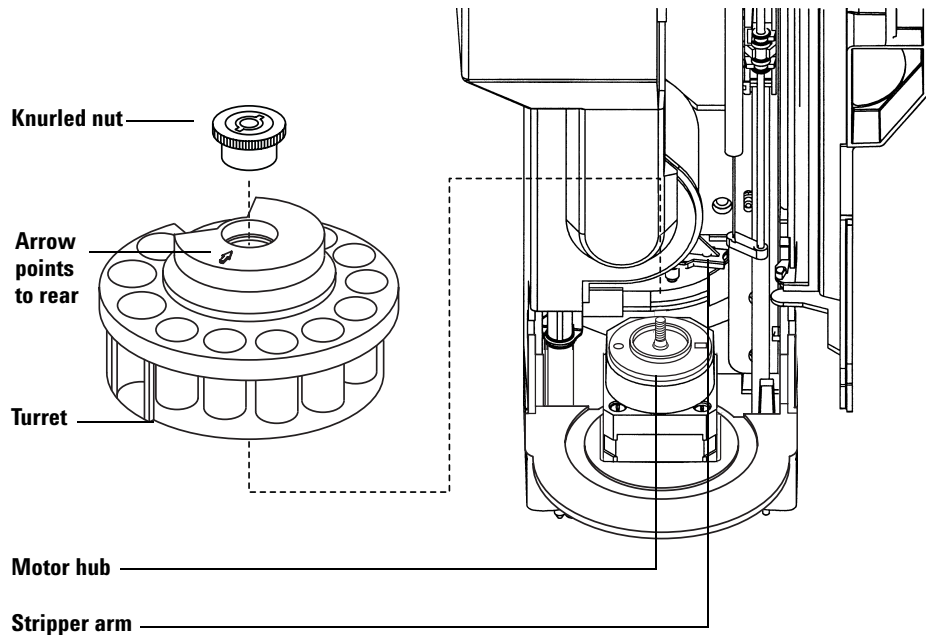

**Figure 60** Removing the turret

- 4 Push the stripper arm to the back of the tower, insert the turret with the open section facing the back of the tower and the arrow pointing back, and install the turret. Seat the turret on the hub, rotating it gently until it drops partially into position then push it down. The top of the threaded shaft will be almost level with the top of the turret.
- 5 Replace the knurled nut and tighten it firmly using fingers only.
- 6 Close the injector door. The injector will verify the turret type if it is powered. If the fault light comes on the turret is not installed correctly.
- 7 If using the 5890 ALS controller software, select **Read Settings from ALS** to upload the new turret type.

## Align Mode

**NOTE**

Agilent does not recommend performing this procedure unless the Align Mode light turns on. It is not necessary to align the turret after changing turrets.

When the orange Align Mode light is on, the injector will not operate until this procedure has been successfully performed.

- 1 When the injector is not operating, remove all the vials from the turret.
- 2 Open the injector tower door.
- 3 Slide the syringe carriage up until it stops.
- 4 Remove the syringe. See “[Removing a Syringe](#)” on page 106 for details.
- 5 Remove the injector from the mounting post, then remove the calibration probe from the bottom of the injector. See [Figure 61](#). Save the screw and washer for later probe storage.

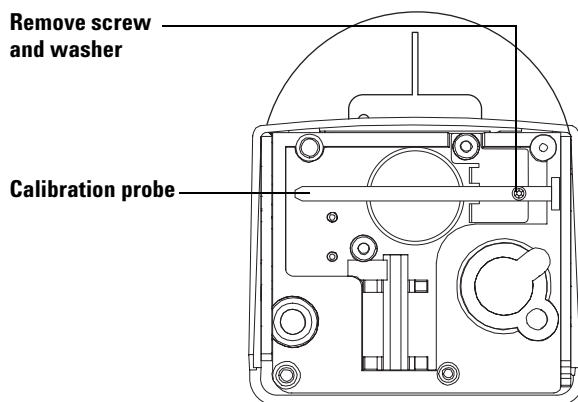

**Figure 61** Removing the calibration probe

- 6 If using a 6890N GC, display sampler messages. Press the **Options** key, scroll to and select **Diagnostics**, then scroll to and select **Front** (or **Back**) **injector**.

- 7 Carefully remove the needle support assembly from the injector. See “Replacing the Needle Support Assembly on the G2913A Injector” on page 153 for details.
- 8 Use the round end of the needle support assembly to press the recessed Alignment button above the indicator lights. See Figure 62.

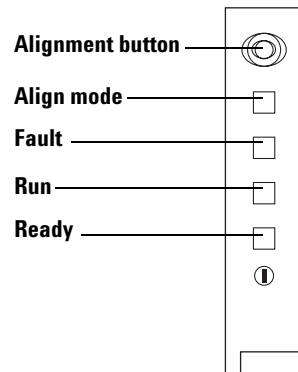

**Figure 62** Aligning the turret

The injector goes through the following steps:

- a The injector clears the syringe carriage for turret rotation.
- b The turret rotates to verify that the needle support assembly was removed, then rotates to determine what type of turret is installed.
- c The syringe carriage moves all the way down, homes, then moves back up again.
- d The syringe carriage steps down until it touches the turret. This sets its position relative to the turret.
- e The plunger moves to calibrate stops.

During these checks, the 6890N and 6850 GC will display diagnostic messages.

#### NOTE

If any of these steps fails, the process will halt. If it halts at step **b**, confirm that the turret is installed correctly and press the Alignment button again. If it fails again, unplug the injector, reconnect it, and try one more time before obtaining Agilent service.

- 9 When the injector stops and all four indicator lights flash, install the calibration probe into the syringe carrier. The probe installs just like a syringe (Figure 63).

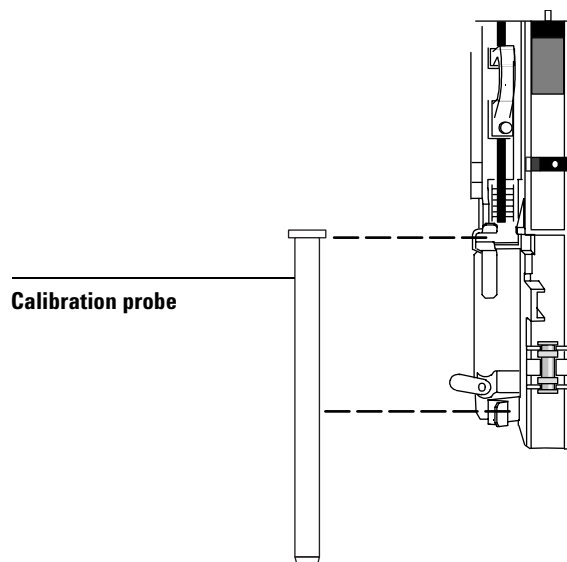

**Figure 63** Installing the calibration probe

- 10 Press the Alignment button again.
  - a The syringe carriage moves down and the turret rotates to verify that the probe is installed.
  - b The turret rotates the calibration hole under the probe.
  - c The probe moves down to calibrate the turret to the syringe carriage.
- 11 When alignment is complete, the orange Align Mode light will go out. Remove the calibration probe and secure it in its clamp below the turret using the screw removed in step 5. See Figure 61.

If the Align Mode light stays on after recycling power, see “Faults” on page 160.

If this alignment was user-initiated (orange Align Mode light was off before pressing the Alignment button) and alignment fails, unplug the injector, reconnect it, and it will reset to the old alignment values.

- 12 Install the needle support assembly and syringe.



## Replacing the Needle Support Assembly on the G2913A Injector

Use the standard needle support assembly for all injections except cool on-column injections with a 250- $\mu\text{m}$  or 320- $\mu\text{m}$  column. For these injections, you must change the needle support assembly to Agilent accessory G2918A.

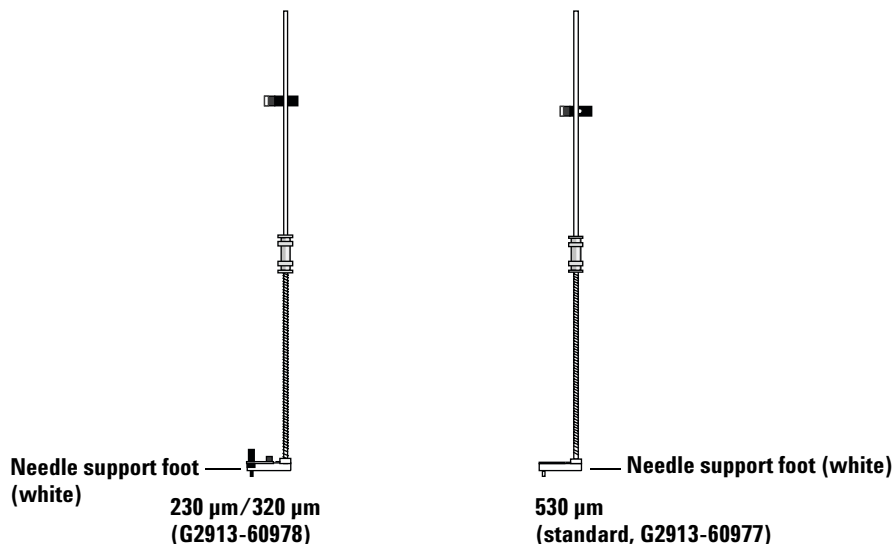

**Figure 64** Needle support assemblies

### NOTE

The G2913A is not compatible with G2613A needle support assemblies. A G2913A needle support has a white foot. The G2613A needle support assembly has a gray foot.

To replace the needle support assembly:

- 1 Remove all vials and bottles from the turret, and disconnect the injector cable from the GC.
- 2 Open the injector door.

3 Remove the syringe.

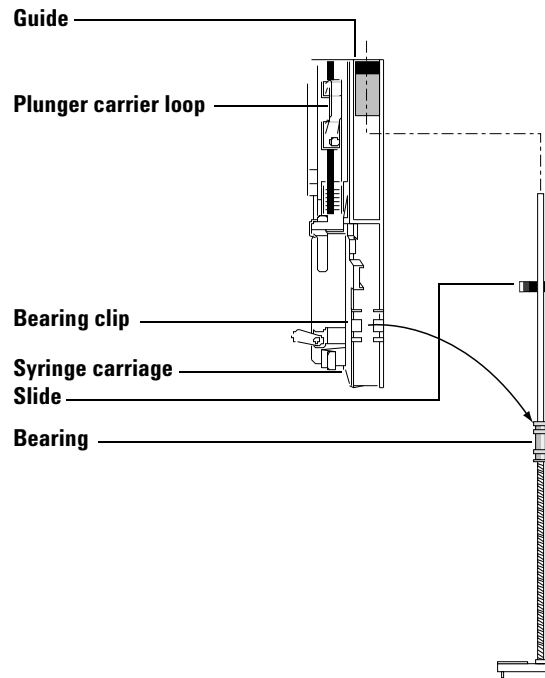

**Figure 65** Removing the needle support assembly

- 4 With your finger under the shaft near the bearing on the needle support assembly, pull gently to release the bearing from the bearing clip in the syringe carriage.
- 5 Carefully use the **bearing** to pull the rod down until you can lift the assembly out of the syringe carriage.

**CAUTION**

Be careful not to pull the assembly *by its metal shaft*. The shaft is easily bent.

- 6 To reinstall the needle support assembly, hold it in your right hand and insert the upper end of the rod into the plastic guide to the right of the plunger carrier loop.

- 7 Turn the needle support assembly so that the flat surface of the slide glides up and down the syringe carriage tracks (Figure 66).

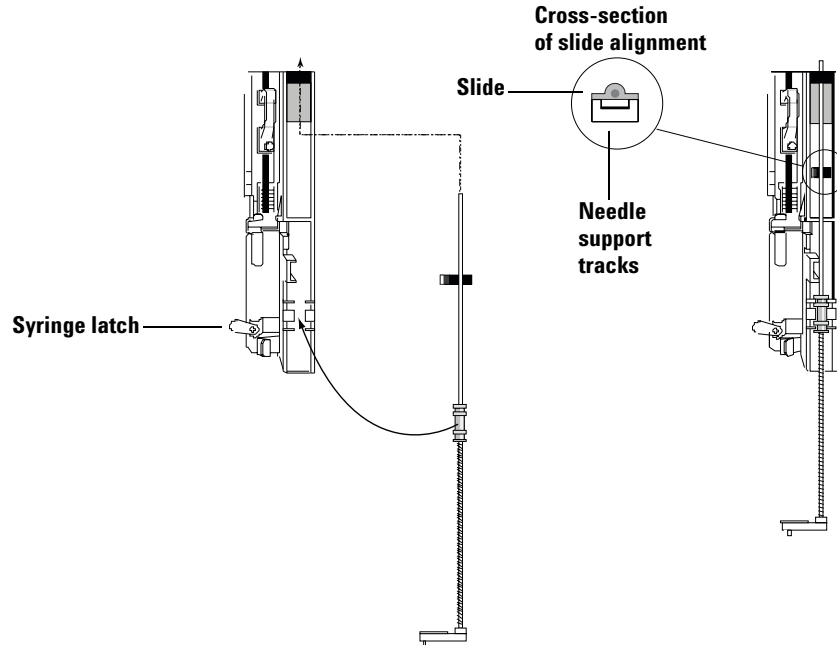

**Figure 66** Installing the needle support assembly

- 8 Align the bearing on the needle support assembly with the plastic bearing clip to the right of the syringe latch and push gently on the bearing until the assembly snaps into place.
- 9 Place the injector back on the GC.

**CAUTION**

Be careful not to bend the needle during installation.

**CAUTION**

Do not operate the injector without a syringe or align probe in place because the free swinging syringe latch may interfere with the motor and jam the syringe carriage.

## 8 Maintenance

- 10 Install the syringe. See “[Installing a Syringe](#)” on page 103 for details.
- 11 Move the slide up and down to make sure the needle is aligned with the needle guide in the support foot. The needle should slide smoothly in the needle guide.

## Replacing the Needle Guide in the Needle Support Foot

When using the needle support assembly (G2913-60978) for 250-/320- $\mu\text{m}$  cool on-column injections, the needle guide is replaceable. Check the needle guide in the needle support foot for wear whenever you change the inlet septum. When the needle guide shows signs of wear, replace it ([Figure 67](#)):

- 1 With an Allen wrench, remove the screw from the needle support foot.
- 2 Remove the small metal plate from the foot.
- 3 Replace the needle guide.
- 4 Replace the metal plate.
- 5 Replace the screw and tighten.

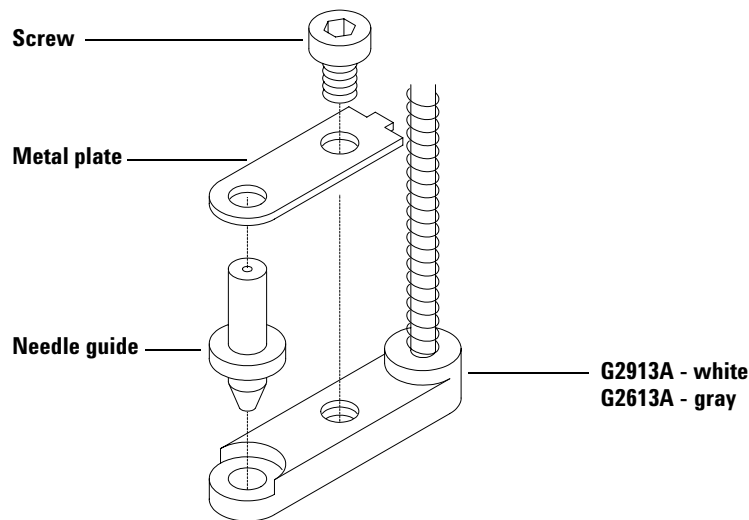

250- $\mu\text{m}$  assembly shown. 320- $\mu\text{m}$  assembly is similar.

See [Figure 77](#) for replacement part numbers.

**Figure 67** Replacing the needle guide

## Replacing Power Fuses in the G2912A ALS Controller

The controller uses two replaceable fuses to protect its electronics from line voltage problems. If blown, replace them as described below.

### CAUTION

Fuses blow for a reason. The most likely cause at first installation is an incorrect power configuration (see “[Procedure 8. Install the G2912A ALS Controller](#)” on page 55). Otherwise, normal operation should not blow the fuses. If the fuses blow frequently, identify and correct the problem

- 1 Turn off the controller.
- 2 Remove the power cord.
- 3 Remove the fuse holder module using a small, flat-bladed screwdriver. (See “[Procedure 8. Install the G2912A ALS Controller](#)” on page 55 for details.)
- 4 Install new fuses as shown in [Figure 68](#).

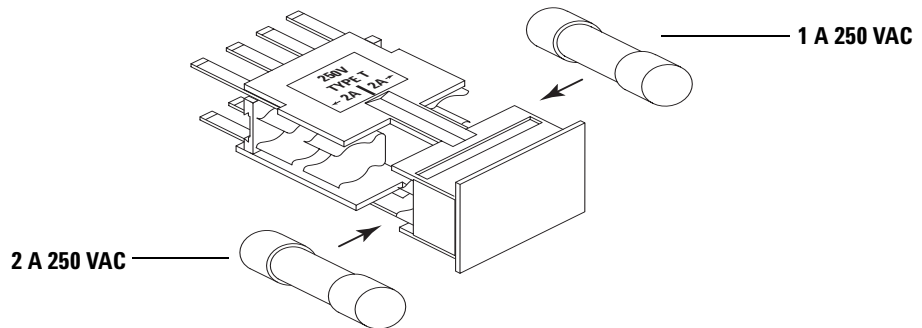

**Figure 68** Proper fuse orientation

- 5 Reinstall the fuse holder module, making sure the orientation is correct for the line voltage input. See “[Procedure 8. Install the G2912A ALS Controller](#)” on page 55 for details.

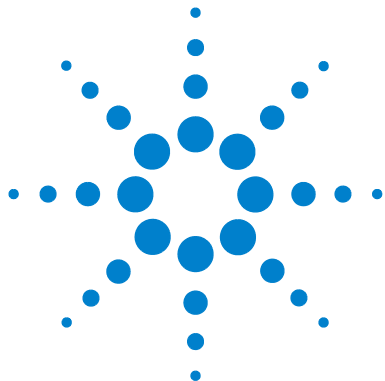

## 9 Faults and Errors

Faults	160
Error Messages	162

Sometimes things do not work as expected. In most cases, the nature of the problem is signalled either by lights on the injector (Faults) or by Error Messages on the GC display. If this happens, use this chapter to discover the probable cause and the corrective action to take.



## Faults

Four lights on the injector indicate its status (Figure 69).

During normal operation, the Ready light is on. If the injector is busy, the Run light is on.

If another combination of lights is on, an error has occurred.

Use the information in this chapter to try to solve the problem before obtaining Agilent service.

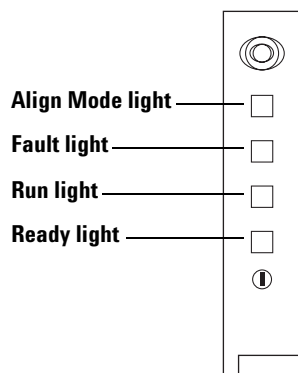

**Figure 69** Injector status lights

**Table 24** Status lights

Lights	Possible cause	Action
All lights are off.	<ul style="list-style-type: none"> <li>The line voltage to the GC is off.</li> <li>The injector cable or connection to the GC is bad.</li> <li>Your GC requires service.</li> </ul>	<ol style="list-style-type: none"> <li>1 Verify the injector is properly connected to the GC.</li> <li>2 Check the power source for your GC.</li> <li>3 Obtain Agilent service.</li> </ol>



**Table 24** Status lights (continued)

Lights	Possible cause	Action
Fault light is on.	<ul style="list-style-type: none"> <li>The injector door is open.</li> <li>Turret is not recognized if door is closed.</li> </ul>	<ol style="list-style-type: none"> <li>1 Ensure that the injector door is closed.</li> <li>2 Re-install turret.</li> <li>3 If the fault light stays on, obtain Agilent service.</li> </ol>
Fault and Run lights are on.	<ul style="list-style-type: none"> <li>The injector is mounted incorrectly on the mounting post.</li> <li>Incorrect mounting post.</li> </ul>	<ol style="list-style-type: none"> <li>1 Ensure that the injector is mounted properly. For more information, see <a href="#">“Procedure 3. Installing the Injectors”</a> on page 42.</li> <li>2 Ensure the correct mounting post is installed. See <a href="#">“Procedure 3. Installing the Injectors”</a> on page 42.</li> <li>3 If the Fault and Run lights stay on, obtain Agilent service.</li> </ol>
Align Mode light is on.	<ul style="list-style-type: none"> <li>The system was not initialized.</li> <li>There is an injector memory error.</li> <li>Customer pushed the align mode button.</li> </ul>	<ol style="list-style-type: none"> <li>1 Verify the turret is properly installed. See <a href="#">“Changing the Turret”</a> on page 147.</li> <li>2 Perform the alignment procedure to initialize the system. See <a href="#">“Align Mode”</a> on page 150.</li> <li>3 If alignment fails, obtain Agilent service.</li> </ol>
All lights are on	<ul style="list-style-type: none"> <li>There is a board failure.</li> <li>There is a firmware revision conflict.</li> </ul>	<ol style="list-style-type: none"> <li>1 Check all cable connections.</li> <li>2 Turn the instrument off, then on again.</li> <li>3 If the lights remain on, obtain Agilent service.</li> </ol>

## Error Messages

Table 25 lists the sampler error messages as reported on the 6850 and 6890 series GCs and through the 5890 Series II ALS Controller software. If you receive an error message that is not shown below, record it. Make sure that your GC is properly configured and that your sample vials and equipment match your method and/or sequence. If the problem continues, report your error message to Agilent service.

**Table 25** Error messages

Message	Probable cause	Suggested action
<b>Bottle in gripper</b>	<ul style="list-style-type: none"> <li>The sample vial was not delivered properly and stayed in the tray gripper.</li> </ul>	<ol style="list-style-type: none"> <li>Remove the vial and return it to its position in the tray.</li> <li>Ensure that the tray quadrants are snapped into place.</li> <li>Ensure that the injector is plugged into the correct connector on the back of the GC. For 6890, ensure it is configured properly. See <a href="#">“Procedure 4. Connecting Cables”</a> on page 46.</li> <li>Check the <b>deliver to</b> location for the vial and verify that the location is empty and free from obstructions.</li> <li>Make sure that the injector is upright/vertical on the GC.</li> <li>Restart the sequence.</li> <li>If the error occurs again, obtain Agilent service.</li> </ol>
<b>Front (or Back) door open or Injector not mounted</b>		<ul style="list-style-type: none"> <li>See <a href="#">“Faults”</a> on page 160.</li> </ul>
<b>Front (or Back) injector com error</b>	<ul style="list-style-type: none"> <li>There is a communications error between the injector and the GC.</li> </ul>	<ul style="list-style-type: none"> <li>Obtain Agilent service.</li> </ul>

**Table 25** Error messages (continued)

Message	Probable cause	Suggested action
<b>Front (or Back) injector incomplete injection</b>	<ul style="list-style-type: none"> <li>The syringe needle is bent.</li> <li>The plunger or syringe carriage is operating incorrectly during injection.</li> </ul>	<ol style="list-style-type: none"> <li>See <a href="#">“Correcting Syringe Problems”</a> on page 175.</li> <li>Remove the syringe from the injector and check the plunger for stickiness or binding. Replace the syringe if necessary.</li> <li>Restart the sequence.</li> <li>If the error occurs again, obtain Agilent service.</li> </ol>
<b>Front (or Back) injector reset</b>	<ul style="list-style-type: none"> <li>There is an interruption in the power supply from the GC.</li> </ul>	<ul style="list-style-type: none"> <li>Obtain Agilent service.</li> </ul>
<b>Front (or Back) plunger error</b>	<ul style="list-style-type: none"> <li>The syringe plunger is sticking or not securely connected to the plunger carrier.</li> <li>The plunger solenoid is binding.</li> <li>The plunger carrier encoder is inoperable.</li> </ul>	<ol style="list-style-type: none"> <li>Remove the syringe and check it for plunger stickiness or binding. Replace the syringe if necessary. For more information, see <a href="#">“Inspecting a syringe”</a> on page 102.</li> <li>Check the viscosity of the sample against the viscosity parameter. Reset the viscosity parameter if necessary.</li> <li>Restart the sequence.</li> <li>If the error occurs again, obtain Agilent service.</li> </ol>
<b>Front (or Back) syringe error</b>	<ul style="list-style-type: none"> <li>The syringe carriage motor is defective.</li> <li>The syringe is not currently installed or is an incorrect type.</li> <li>The syringe carriage sensor is inoperable.</li> </ul>	<ol style="list-style-type: none"> <li>Ensure the syringe is installed correctly. For more information, see <a href="#">“Installing a Syringe”</a> on page 103.</li> <li>Ensure the syringe meets specifications.</li> <li>If the syringe needle is bent, see <a href="#">“Correcting Syringe Problems”</a> on page 175.</li> <li>Restart the sequence.</li> <li>If the error occurs again, obtain Agilent service.</li> </ol>

Table 25 Error messages (continued)

Message	Probable cause	Suggested action
<b>Front (or Back) turret error</b>	<ul style="list-style-type: none"> <li>Something has interfered with the turret rotation.</li> <li>The turret motor/encoder assembly is inoperable.</li> <li>The turret type was changed while the power was on and the turret alignment procedure was not performed.</li> <li>Turret is loose.</li> </ul>	<ol style="list-style-type: none"> <li>1 Clear any obstructions.</li> <li>2 Check the Align Mode light. If it is on, perform the alignment procedure. See “Align Mode” on page 150.</li> <li>3 Tighten the knurled nut on the top of the turret.</li> <li>4 If the error occurs again, obtain Agilent service.</li> </ol>
<b>Injector not present</b>	<ul style="list-style-type: none"> <li>There is a board failure in the injector or GC.</li> <li>The injector cable is bad or not securely connected to the GC.</li> <li>There is a cable failure in the GC.</li> <li>Your method specifies an incorrect injector location (method mismatch).</li> </ul>	<ol style="list-style-type: none"> <li>1 Make sure that the injector-to-GC cable connection is secure.</li> <li>2 Check your method to make sure it uses the appropriate injector location.</li> <li>3 If the error remains, obtain Agilent service.</li> </ol>
<b>Injector offline</b>	<ul style="list-style-type: none"> <li>There is a board failure in the injector or GC.</li> <li>The injector cable is bad or not connected.</li> <li>There is a cable failure in the GC.</li> </ul>	<ol style="list-style-type: none"> <li>1 Make sure that the injector to GC cable connection is secure.</li> <li>2 If the error remains, obtain Agilent service.</li> </ol>
<b>No Bar Code Reader</b>	<ul style="list-style-type: none"> <li>Bar Code Reader cable not securely connected.</li> <li>Bar Code Reader is defective.</li> <li>Tray is defective.</li> </ul>	<ol style="list-style-type: none"> <li>1 Ensure the Bar Code Reader cable connection is secure.</li> <li>2 If the problem continues, obtain Agilent service.</li> </ol>
<b>No bottle in gripper</b>	<ul style="list-style-type: none"> <li>The sample vial was not found by the gripper.</li> <li>The gripper could not grasp the vial.</li> <li>The vial was dropped during transfer to or from the turret.</li> <li>The sensor in the gripper is defective.</li> <li>The vial does not meet specifications.</li> </ul>	<ol style="list-style-type: none"> <li>1 Make sure that the sample vials are in the locations specified by the sequence.</li> <li>2 Make sure that the sample vials meet recommended specification.</li> <li>3 If you are using adhesive labels, verify that the labels are properly installed. See “Labeling sample vials” on page 112.</li> <li>4 If the error recurs frequently, obtain Agilent service.</li> </ol>

**Table 25** Error messages (continued)

Message	Probable cause	Suggested action
<b>Tray not present</b>	<ul style="list-style-type: none"> <li>• There is a board failure in the tray or GC.</li> <li>• The tray cable is bad or not connected between the GC and tray.</li> <li>• There is a cable failure in the GC.</li> </ul>	<ol style="list-style-type: none"> <li>1 Make sure that the tray cable connection is secure.</li> <li>2 Replace the tray cable.</li> <li>3 If the error remains, obtain Agilent service.</li> </ol>
<b>Tray offline</b>	<ul style="list-style-type: none"> <li>• There is a board failure in the tray or GC.</li> <li>• The tray cable is bad or not connected.</li> <li>• There is a cable failure in the GC.</li> </ul>	<ol style="list-style-type: none"> <li>1 Make sure that the tray to GC cable connection is secure.</li> <li>2 Replace the tray cable.</li> <li>3 If the error remains, obtain Agilent service.</li> </ol>
<b>Autoinject aborted</b>	<ul style="list-style-type: none"> <li>• The autoinject sequence on a 6850 GC was aborted.</li> </ul>	<ul style="list-style-type: none"> <li>• Other error messages shown on the GC display provide more information on what caused the sequence to abort.</li> </ul>
<b>Invalid sequence</b>	<ul style="list-style-type: none"> <li>• The sequence is set up for the wrong injection device.</li> <li>• Hardware required by the sequence is not installed and configured.</li> <li>• The GC configuration was changed during sequence execution.</li> <li>• The injector cable is bad or not connected properly.</li> </ul>	<ol style="list-style-type: none"> <li>1 Make sure that the connection to the GC is secure.</li> <li>2 Verify the sequence parameters against the GC configuration.</li> <li>3 If the error remains, obtain Agilent service.</li> </ol>
<b>No injector</b>	<ul style="list-style-type: none"> <li>• The cabling connection to the GC became loose during a run.</li> <li>• An injector board or GC board failed during a run.</li> </ul>	<ol style="list-style-type: none"> <li>1 Make sure that the connection to the GC is secure.</li> <li>2 If the error remains, obtain Agilent service.</li> </ol>
<b>Prerun &gt;10 min</b>	<ul style="list-style-type: none"> <li>• The GC is Not Ready.</li> </ul>	<ul style="list-style-type: none"> <li>• Check for Not Ready and other GC messages to determine the cause.</li> </ul>
<b>Sampler error (6850 only)</b>	<ul style="list-style-type: none"> <li>• The sampler could not function for an undocumented reason.</li> </ul>	<ul style="list-style-type: none"> <li>• Record the code number shown in the G2629A Control Module error message. If the problem persists, obtain Agilent service and report the error number.</li> </ul>



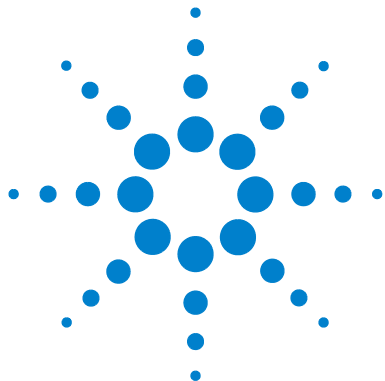

## 10 Troubleshooting

Symptom: Variability	168
Symptom: Contamination or Ghost Peaks	170
Symptom: Smaller or Larger Peaks Than Expected	171
Symptom: Sample Carryover	173
Symptom: No Signal/No Peaks	174
Correcting Syringe Problems	175
Correcting Sample Vial Delivery Problems	176

The information in this chapter will assist you in keeping the sampler running smoothly.

The chromatogram is not satisfactory; clearly something is wrong. Use this chapter to determine the probable cause and, in many cases, the cure for the problem.

This chapter deals only with sampler-related problems. However, many of the symptoms described here could also come from other sources, particularly the stability of the gas chromatograph temperature and its gas supplies.

If you cannot correct the problem, obtain Agilent service.



## Symptom: Variability

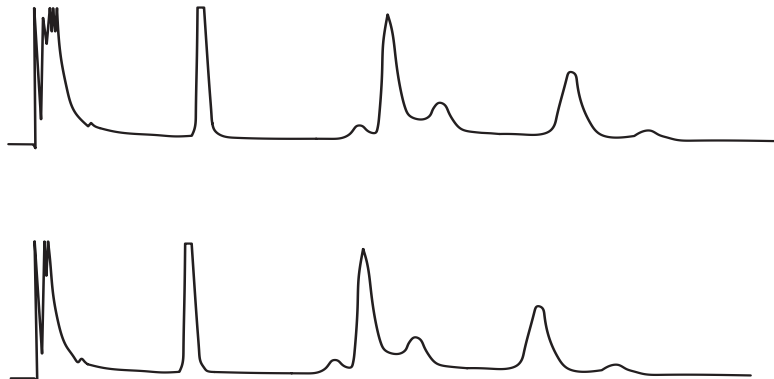

**Figure 70** Retention times or areas are not reproducible

**Table 26** Variability problems

Possible cause	Action
Inlet septum is leaking.	If the septum is leaking, replace it. If the septum you replaced experienced less than 200 injections, check for the following possible problems to prevent premature septum failure: <ul style="list-style-type: none"> <li>• The septum retainer nut is too tight.</li> <li>• The syringe needle is not straight.</li> <li>• The syringe is not installed correctly.</li> </ul>
Syringe is worn or dirty.	If the syringe looks dirty or the plunger is sticking, clean the syringe with an appropriate solvent or follow the syringe manufacturer's cleaning instructions.
Sample volume is too low or too high.	Check sample level. If the sample vials are not filled correctly, evaporation or contamination may affect the analysis. The sample level should be approximately half the volume of the vial. See <a href="#">"Filling sample vials"</a> on page 112.



**Table 26** Variability problems (continued)

Possible cause	Action
Vial caps are loose.	Check vial caps. If you can turn the vial crimp cap by hand, they are too loose. Loose caps may cause volatile samples to change concentration over time. See <a href="#">“Capping sample vials”</a> on page 113.
Sample is not stable.	Check the sample stability. Some samples change with heat or ultraviolet light. There are several ways to reduce changes to unstable samples: <ul style="list-style-type: none"> <li>• Use the tray quadrants to cool the sample.</li> <li>• Use amber sample vials.</li> <li>• Store the samples in a protected environment.</li> </ul>
Sample size varies.	Install a new syringe. If the sample size varies, the syringe is probably not precise or the plunger is worn. Variation may be due to syringes with removable needles because of dead volume or needle-to-needle variation.
Air bubbles are in the needle.	If air bubbles are in the needle, increase the run parameter that controls the number of sample pumps. See <a href="#">“Setting Injector Parameters on a 6890 GC”</a> on page 87. If this does not help and the sample is viscous, try the following: <ul style="list-style-type: none"> <li>• Increase the viscosity delay time.</li> <li>• Use the tray quadrants to warm the sample.</li> <li>• Dilute the sample in an appropriate low-viscosity solvent.</li> </ul>

## Symptom: Contamination or Ghost Peaks

**Table 27** Contamination or ghost peak problems

Possible cause	Action
Vial cap septum is dissolving in solvent. Ghost peaks sometimes appear when small pieces of septum material dissolve in the sample. Make several blank runs to determine the presence or absence of the ghost peaks.	Check for the following: <ul style="list-style-type: none"> <li>• Be sure the vial septum is flat. If the vial septum is not flat, the needle tends to core the septum and drop pieces into the sample. See “Capping sample vials” on page 113.</li> <li>• Check the needle. If the syringe needle has burrs, it could cut pieces of the septum and push them into the sample.</li> <li>• Check the vial septum. If the vial septum is not resistant enough to the solvent you are using, try a more resistant type.</li> </ul>
Sample vials are contaminated.	Ghost peaks are sometimes caused by contaminated sample vials. Try new or clean vials to see if ghost peaks disappear. Store new vials in a contaminant-free location.
Injection port septum is giving off volatiles.	Make several blank runs with a small piece of aluminum foil backing the inlet septum. If the contamination peaks disappear, they were probably due to the septum. Try replacing the septum you usually use with another type.
Column is contaminated. High molecular weight samples that contain residues may cause the syringe, the inlet liner, or the first few inches of column to become contaminated.	Do the following: <ul style="list-style-type: none"> <li>• Replace or clean and deactivate the inlet liner.</li> <li>• Examine the first few inches of a capillary column for foreign material by holding a light behind it. If possible, remove the contaminated section.</li> </ul>
Sample is not stable.	Some samples change with heat or ultraviolet light. Check the sample stability. There are several ways to reduce the change: <ul style="list-style-type: none"> <li>• Use the tray quadrant to cool the sample.</li> <li>• Use amber sample vials.</li> <li>• Store the samples in a protected environment.</li> </ul>

## Symptom: Smaller or Larger Peaks Than Expected

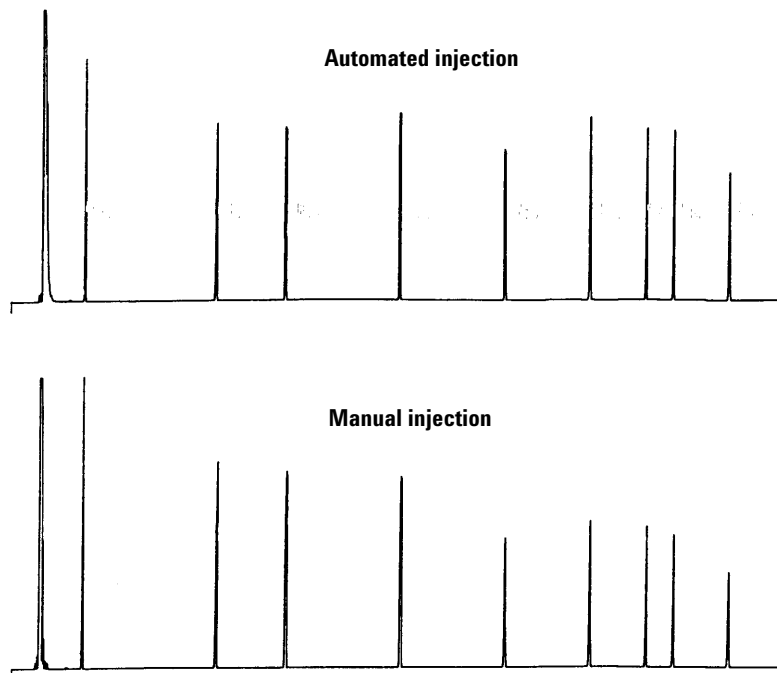

**Figure 71** Smaller or larger peaks than expected

**Table 28** Peak size problems

Possible cause	Action
You are comparing a chromatogram without needle fractionation against one with needle fractionation.	Check your injection mode. In the normal injection mode, the sampler uses fast injection to deliver a representative amount of the sample. Fast injection minimize needle fractionation. Chromatograms from manual injection or slower auto injection devices show higher levels of low molecular weight materials versus higher molecular weight materials because the volatiles boil out of the needle faster than the higher weight materials.

**Table 28** Peak size problems (continued)

Possible cause	Action
You are using a packed inlet and a 530- $\mu$ m column.	Check your inlet. Capillary columns used with packed inlets have some inherent sample discrimination characteristics. See <a href="#">“Suggestions for Packed Inlets with 530-<math>\mu</math>m Columns”</a> on page 184.
There is a leak in the GC system.	Replace the septum and check the fitting for leaks. If the leaking septum has experienced less than 200 injections. To prevent future premature failures, be sure that: <ul style="list-style-type: none"> <li>• The septum retainer nut is not too tight.</li> <li>• The syringe needle is straight.</li> <li>• The syringe is installed correctly.</li> <li>• The injector is aligned to the injection port (7673 only). See <a href="#">“Installing a Syringe”</a> on page 103.</li> </ul>
Sample is not stable.	Some samples change with heat or ultraviolet light. Check the sample stability. There are several ways to reduce the change: <ul style="list-style-type: none"> <li>• Use the tray quadrants to cool the sample.</li> <li>• Use amber sample vials.</li> <li>• Store the samples in a protected environment.</li> </ul>
Vial caps are loose.	Check the vial caps. Loose vial caps can cause selective loss of lighter materials from a sample. The cap should not rotate easily if installed properly. See <a href="#">“Capping sample vials”</a> on page 113.

## Symptom: Sample Carryover

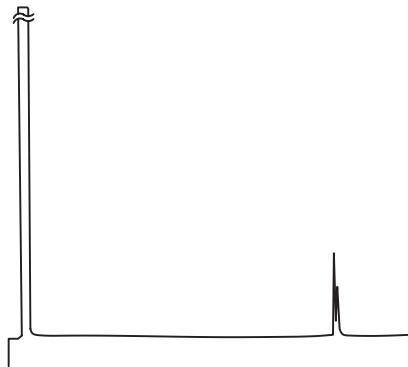

**Figure 72** Blank run showing carryover peaks

**Table 29** Carryover problems

Possible cause	Action
Number or type of washes is insufficient.	Check the run parameters for the number of sample and solvent washes. The number of washes needed depends on your application. See <a href="#">“Sample Carryover”</a> on page 79.
You ran out of solvent.	Check the solvent bottles. If the solvent level is below 2.5 mL, the syringe cannot reach the solvent. Replace the remaining solvent with 4 to 4.5 mL of fresh solvent. See <a href="#">“Preparing Solvent and Waste Bottles”</a> on page 116. Check the waste bottles. If the waste level is near the neck of the bottle, replace it with an empty bottle.
Syringe is worn or dirty.	If the syringe look dirty or the plunger is sticking, clean the syringe with an appropriate solvent or follow the syringe manufacturer’s cleaning instructions. If the syringe seems worn, replace it.
Samples (vial-to-vial) are of immiscible types.	In this situation, the sample and solvent washes may not rinse the syringe properly. Increase the number of wash cycles or use a solvent that rinses a variety of sample types.

## Symptom: No Signal/No Peaks

**Table 30** Signal/Peak problems

Possible cause	Action
Syringe plunger is malfunctioning.	Verify that the syringe plunger is secured by the plunger screw. If the plunger screw is loose, tighten it. See <a href="#">“Installing a Syringe”</a> on page 103. Check the syringe needle for plugging. If the syringe is plugged, replace or clean the syringe.
Sample level is too low in vial.	If there is no or very little sample in the vial, the needle may not be able to reach it. See <a href="#">“Filling sample vials”</a> on page 112. Alternately, you may edit your method to adjust the needle sampling depth. See Sampling offset in <a href="#">“Setting Injector Parameters on a 6890 GC”</a> on page 87.
Sample is viscous.	If the sample is viscous, try the following: <ul style="list-style-type: none"><li>• Increase the viscosity delay time.</li><li>• Use the tray quadrants to warm the sample.</li><li>• Dilute the sample in an appropriate low-viscosity solvent.</li><li>• Turn the tower fan off.</li></ul>

## Correcting Syringe Problems

**WARNING**

When troubleshooting the injector, keep your hands away from the syringe needle. The needle is sharp and may contain hazardous chemicals.

---

Several things can cause syringe needles to bend. When you find one, check for the following conditions before installing a replacement.

- ✓ Was the syringe installed properly in the syringe carriage?
- ✓ Are you using the correct syringe? Is the combined length of the syringe barrel and needle about 126.5 mm? For more information, see “[Syringes](#)” on page 100.
- ✓ Are the needle support and needle guide cone clean? Remove any residue or septum deposits. For more information, see “[Periodic Maintenance](#)” on page 138.
- ✓ Is the correct insert for your syringe installed in the cool on-column inlet? For more information, see “[Cool On-Column Injection](#)” on page 183.
- ✓ Is the GC septum nut too tight? For more information, see your GC operating documentation.
- ✓ Is the septum of the crimp cap centered over the sample vial? For more information, see “[Capping sample vials](#)” on page 113.
- ✓ Are the inside diameters of the sample vial, microvial insert, and vial cap septum at least 5 mm? For more information, see “[Preparing Sample Vials](#)” on page 110.

### Correcting Sample Vial Delivery Problems

When you find a mishandled sample vial, check:

- ✓ Are there folds or wrinkles in the crimp cap, especially near the neck of the sample vial? For more information, see [“Preparing Sample Vials”](#) on page 110.
- ✓ Are you using the correct sample vials? Is the distance from the vial bottom to the top of the neck about 28.4 mm? Is the bottle neck diameter  $8.2 \pm 0.3$  mm? For more information, see [“Selecting sample vials”](#) on page 110.
- ✓ If you use labels on the sample vials, are they the correct size? For more information, see [“Labeling sample vials”](#) on page 112.
- ✓ If you use labels on the sample vials, are they interfering with the gripper? For more information, see [“Labeling sample vials”](#) on page 112.
- ✓ Are there any obstacles to the tray arm or injector turret motions? Remove any obstacles.
- ✓ Are the tray quadrants and turret in good condition? Clean any residue from the sample positions. Temperature-controlled liquid pumped through the quadrants may cause quadrant distortion over time. See [“Tray quadrant temperatures and pressures”](#) on page 181.
- ✓ Does the bottom of a sample vial touch the top of the turret? To adjust gripper height, see [“Setting sample tray setpoints on a 6890 GC”](#) on page 91.
- ✓ Does the side of a sample vial touch the side of the turret hole as the vial is raised or lowered? To adjust the tray arm location, see [“Configuring the injector on a 6890 GC”](#) on page 89.



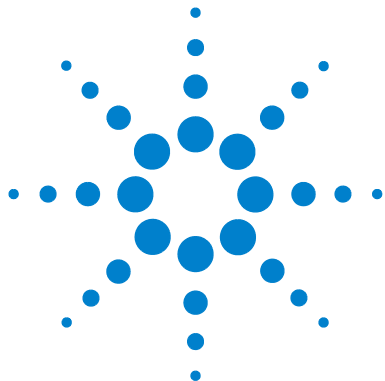

## 11 Special Topics

Controlling Sample Vial Temperatures	178
Connect the tray quadrants	178
Determine the water bath temperature	179
Tray quadrant temperatures and pressures	181
Water bath and pump specifications	181
Coolant	179
Cool On-Column Injection	183
Suggestions for Packed Inlets with 530- $\mu$ m Columns	184

This chapter discusses several topics that, while important, are needed by only a few users.



## Controlling Sample Vial Temperatures

This section explains how to connect tubing to the tray quadrants, how to determine the water bath temperature needed to obtain an approximate sample vial temperature, and the pressure limitations of the quadrants.

This section does not explain how to set up a water bath and pump.

You can control the temperature of the sample vials in the tray by:

- Pumping temperature-controlled liquid through the tray quadrants.
- Freezing an ethylene glycol and water solution inside the tray quadrants.

The quadrants are designed for low flow rates, low pressures, and long temperature equalization times. If you freeze an ethylene glycol or alcohol solution in the quadrants, fill the quadrants to less than 90% of their total capacity.

### CAUTION

Ensure that the drainage tube is attached to the base of the tray and remove any equipment from underneath the tray. When controlling for low sample temperature with high ambient temperature or high humidity, water condensation from the quadrants and tray could damage equipment under the tray.

### Connect the tray quadrants

- 1 Connect a piece of tubing from the drain fitting on the tray to waste.

Tray model	Tubing size
G2916A	1/4-inch id (6.35 mm)
G2614A	3/8-inch id (9.53 mm)

- 2 Connect the tray quadrants together using 1/4-inch id (6.35 mm) tubing (Figure 73).

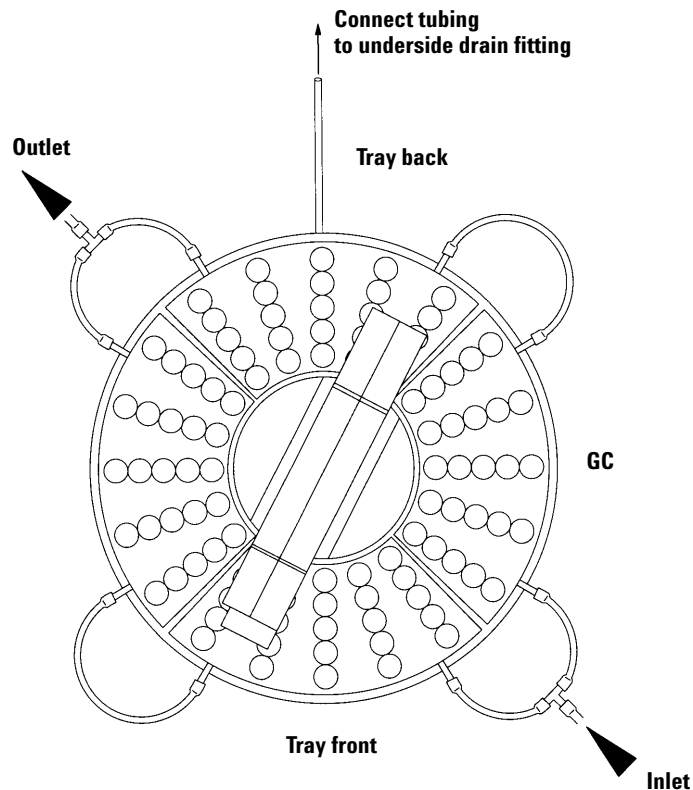

**Figure 73** Tray quadrant plumbing

## Coolant

Use distilled water as your cooling fluid. If desired, you may add a maximum of 3% ethylene glycol to the distilled water to prevent freezing.

## Determine the water bath temperature

The temperature of the sample vials depends on several factors, including the ambient temperature and the temperature of the water bath.

**CAUTION**

If the sample temperature is critical for accuracy, experiments should be performed to validate water bath settings. Actual heat transfer varies with vial material, humidity, condensation on the vial, and flow rates.

Use [Figure 74](#) to determine the water bath temperature.

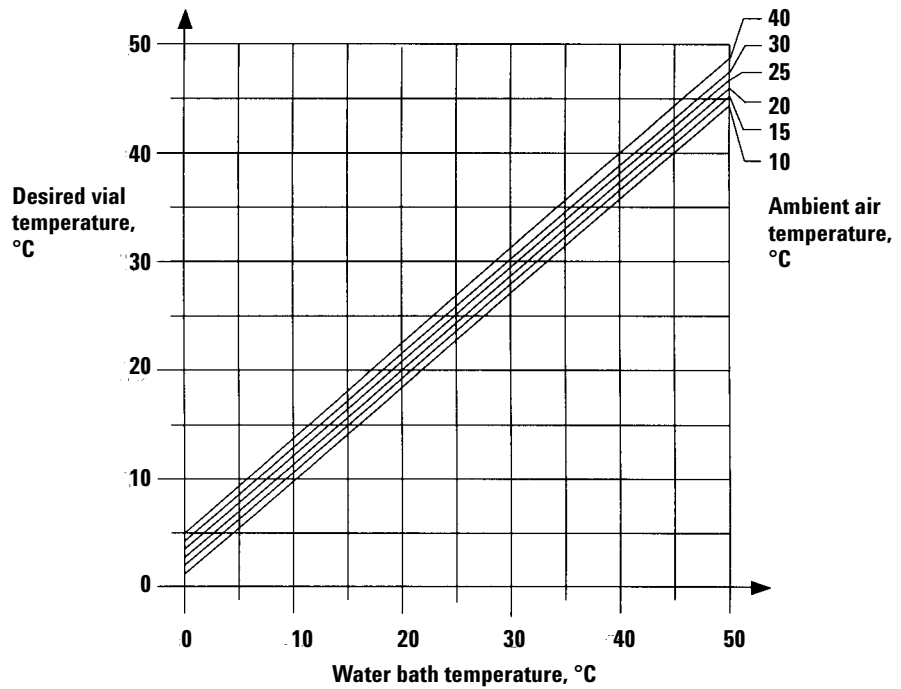

**Figure 74** Vial temperature versus water bath and ambient air temperatures

## Tray quadrant temperatures and pressures

Do not allow the tray inlet pressure and temperature to exceed the limits in [Figure 75](#). If you operate outside this range, the quadrants could be damaged.

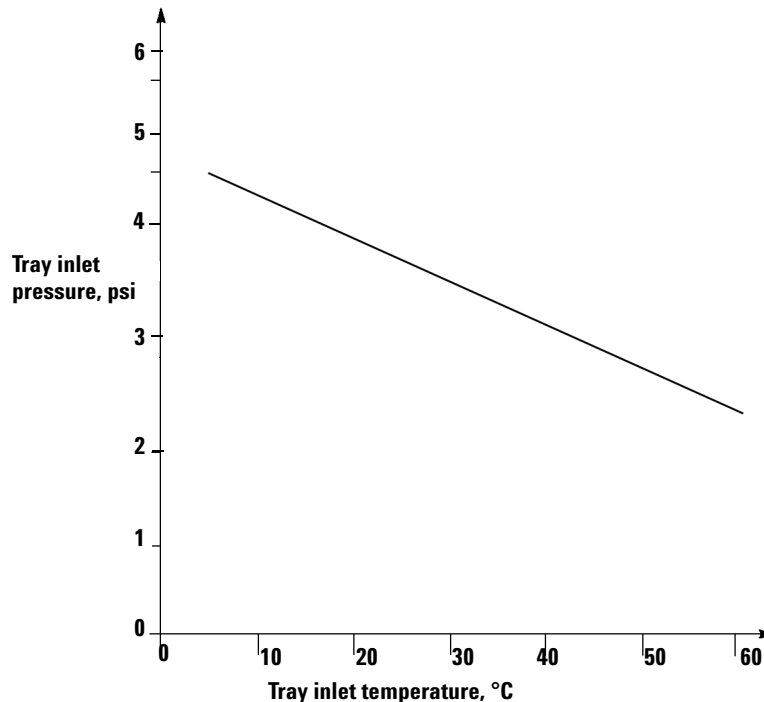

**Figure 75** Maximum tray inlet pressures and temperatures

## Water bath and pump specifications

The water bath and pump system used to control the sample vial temperatures must meet these specifications.

- The components must meet national standards for safety requirements, be suitable for unattended operation, be suitable for continuous operation, and be controllable for high-temperature protection.
- The minimum cooling power required for the water bath is 100 W at bath temperatures of 5 °C.

## 11 Special Topics

- If you use a built-in pump, it must be suitable for external circulation of liquid and for connection of 1/4-in. id (6.35 mm) tubing or larger.
- If you use a pressure pump, it must maintain a pressure from 1.5 to 2.5 psi.
- If you use a suction pump, the pump vacuum cannot exceed -4 psi.

## Cool On-Column Injection

For GCs with a cool on-column inlet, the 7683A/B injector can perform injections directly onto 250- $\mu\text{m}$ , 320- $\mu\text{m}$ , and 530- $\mu\text{m}$  columns. For a list of consumables needed to perform these injections, see [“Replacing Syringe Needles”](#) on page 107.

When performing cool on-column injections, the injector:

- Slows the carriage speed so the overall injection time increases to 500 milliseconds.
- Lowers the tip of the syringe needle an additional 19 mm into the column.

If you need to adapt your injector for cool on-column injection, change the inlet column diameter, or change the septum nut or cool on-column insert, refer to [“Adapting For Cool On-Column Injection”](#) on page 139.

### Suggestions for Packed Inlets with 530- $\mu\text{m}$ Columns

When using a heated, packed inlet with a 530- $\mu\text{m}$  column, do the following:

- Install the column so that no more than 1 to 2 mm of the column extends past the ferrule. This avoids large unswept volumes at the base of the inlet.
- Use polyimide ferrules (Vespel) instead of graphite. A small portion of the column ferrule is exposed to sample vapor.
- Insulate the part of the inlet that projects into the oven. If the oven is programmed to increase temperature, the lower part of the inlet could become a cold spot.



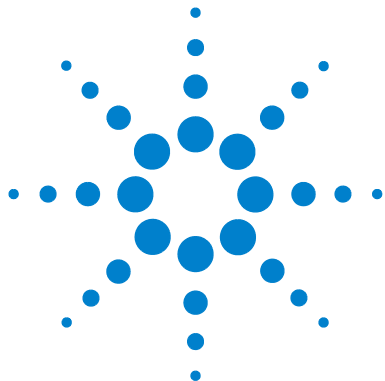

## 12 Replacement Parts

G2912A — 7683B ALS Controller for 5890 Series II and 6890A GCs 186

G2913A — 7683B Injector Module 188

G2614A — 7683 ALS Tray 190

G2916A — 7683 ALS Tray for 5890 Series II GCs 191

Miscellaneous Parts 192

The following pages list the replacement parts for the 7683B Automatic Liquid Sampler. Also refer to the Agilent web site at [www.agilent.com/chem](http://www.agilent.com/chem) for the most up-to-date replacement part and firmware listings.



## G2912A — 7683B ALS Controller for 5890 Series II and 6890A GCs

Table 31 and Figure 76 list and show the replacement parts for the 7683B ALS controller.

### WARNING

Replacement of internal fuses and the battery can expose the servicing person to hazardous voltages and also exposes the controller to damage. Replacement is not covered in this manual. Refer servicing to qualified, Agilent-trained personnel.

**Table 31** G2912A ALS Controller replacement parts

Item	Description	Part No.	Qty/Assy
1	G2912A Controller (new) G2912A Controller (exchange)	G2912-60703 G2912-69703	
2	Fuse, 2 A 250 VAC	2110-0792	2
NS	Fuse, power supply PCA	2110-0782 <sup>*</sup>	1
NS	Fuse, ALS controller PCA	2110-0961 <sup>*</sup>	1
NS	Battery, 3 V .5 A, Lithium ion	1420-0523 <sup>*</sup>	1

\* Replacement of this part can expose the servicing person to hazardous voltages and also exposes the controller to damage. Replacement is not covered in this manual. Refer servicing to qualified, Agilent-trained personnel.

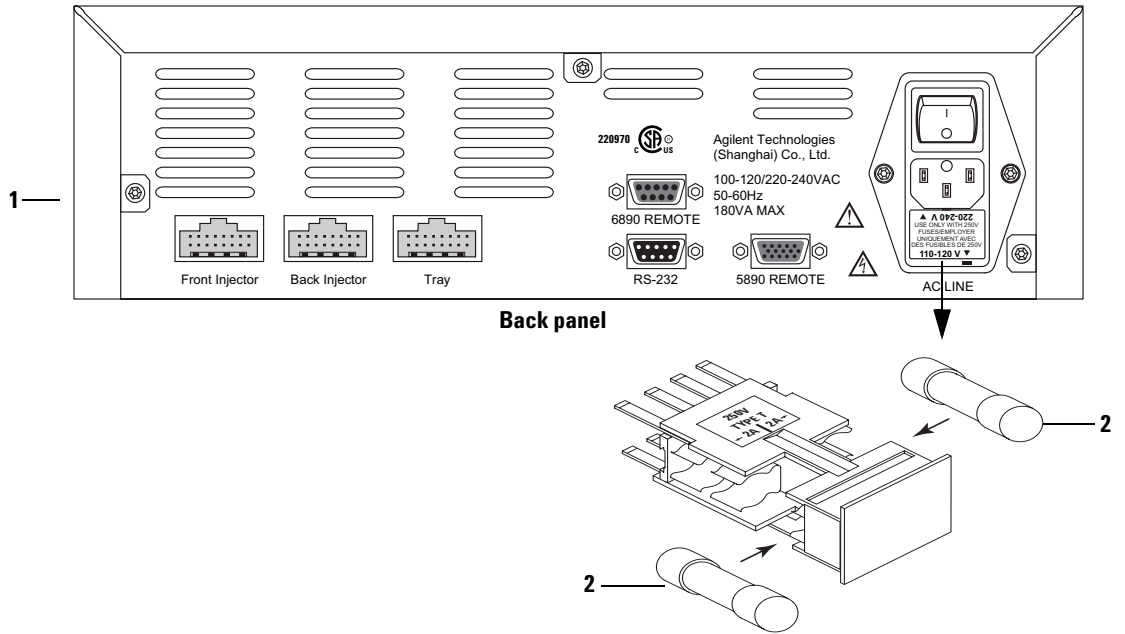

**Figure 76** Replacement parts for the 7683B ALS controller

## G2913A — 7683B Injector Module

Table 32 and Figure 77 list and show the replacement parts for the 7683B injector module.

**Table 32** G2913A injector replacement parts

Item	Description	Part no.	Qty/Assy
1	Injector module (new) Injector module (exchange)	G2913-60910 G2913-69910	
2	Injector mounting post for 6890 and 6850	G2613-20500	1 (6850) 2 (6890)
3	Injector mounting post for 5890 Series II	G2916-25010	2
4	Hi-density injector turret kit	G2913-60630	1
5	Injector turret, standard	G2913-40000	1
6	530 $\mu\text{m}$ Needle support assembly	G2913-60977	
7	250/320 $\mu\text{m}$ Needle support assembly (for on-column injections only)	G2913-60978	
8	Alignment probe	G2913-60500	1
9	Thumbnut assembly	G2913-60680	1
10	Needle support kit, 250/320, includes metal plate, and cool on-column septum nut	07673-61330	
11	Needle support kit, 250/320, includes metal plate, plastic guide and screw	07673-61340	
NS	6890 inlet chassis cover	G1530-40070	

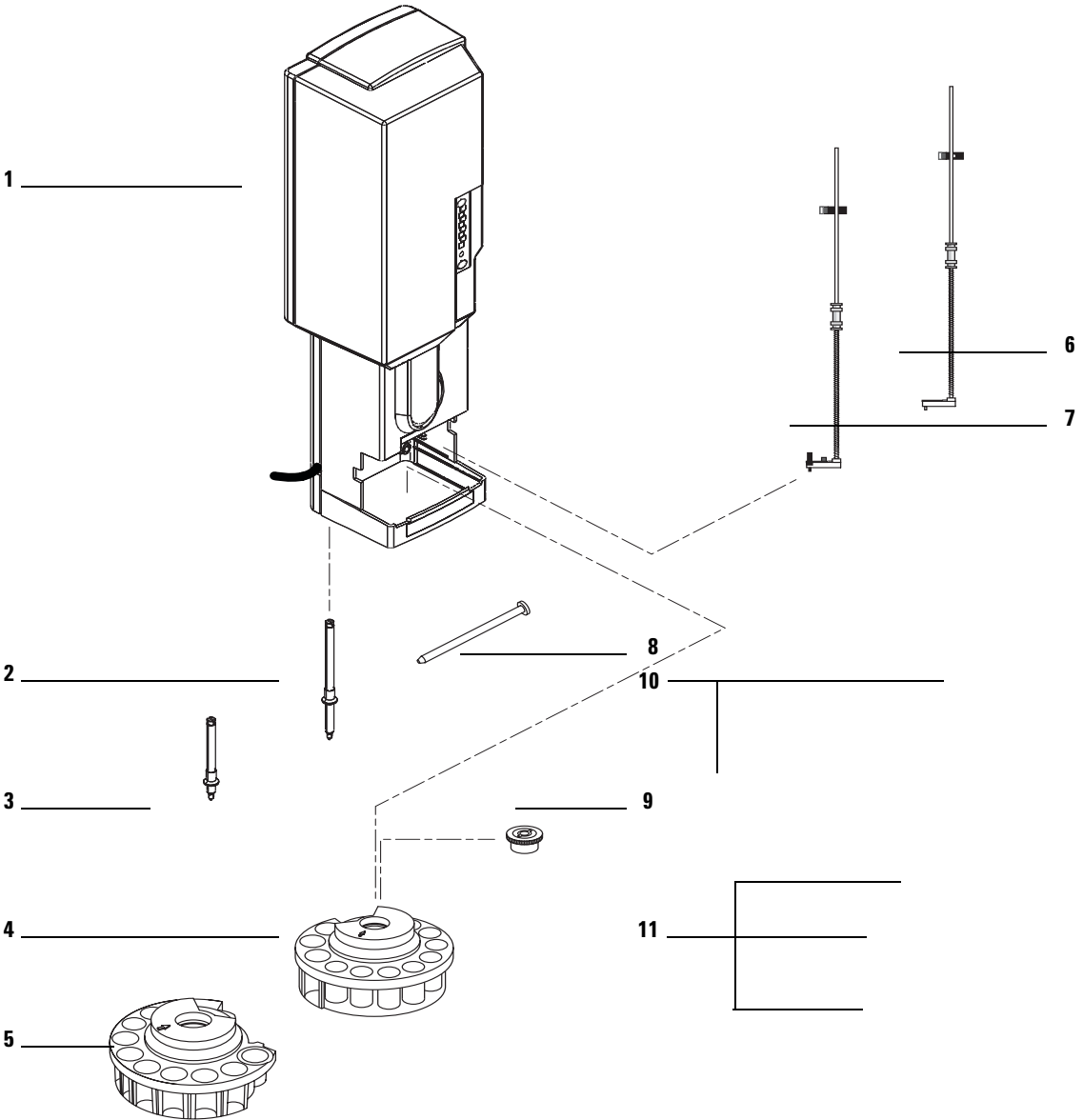

Figure 77 G2913A injector replacement parts

## G2614A — 7683 ALS Tray

Table 33 and Figure 78 list and show the replacement parts for the 7683B injector module.

**Table 33** G2614A tray replacement parts

Item	Description	Part no.	Qty/ Assy
1	Tray module assembly (new) Tray module assembly (exchange)	G2614-60965 G2614-69965	
2	Torx screw, T-20, M4 × 45 mm	0515-2484	2
3	Quadrant, 4/pkg	18596-40015	1
4	Torx screw, T-20, M4 × 20 mm	1390-1024	1
NS	Main tray cable	G2614-60610	1

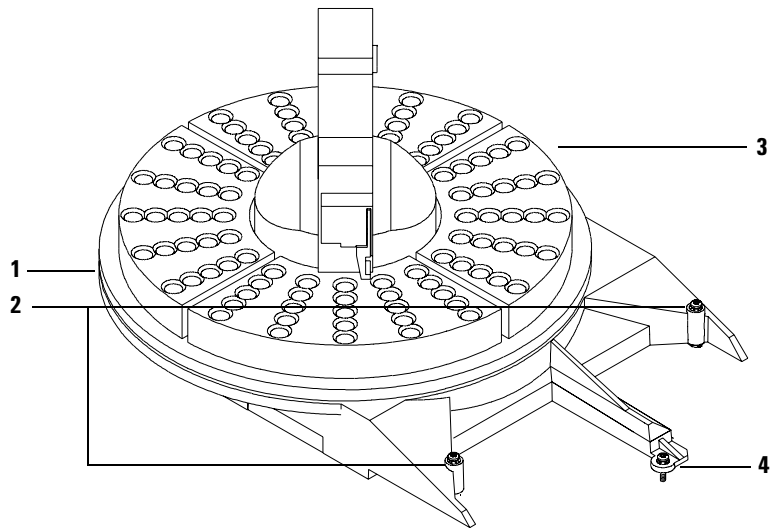

**Figure 78** G2614A tray replacement parts

# G2916A — 7683 ALS Tray for 5890 Series II GCs

Table 34 and Figure 79 list and show the replacement parts for the 7683B ALS tray for 5890 Series II GCs.

**Table 34** G2916A tray replacement parts

Item	Description	Part no.	Qty/ Assy
1	Tray module assembly (new) Tray module assembly (exchange)	G2916-60965 G2916-69965	
2	Quadrant, 4/pkg	18596-40015	1
3	Tray screw kit	G2916-80510	1
4	Tray standoff	G29116-25040	1
NS	Main tray cable	G2614-60610	1

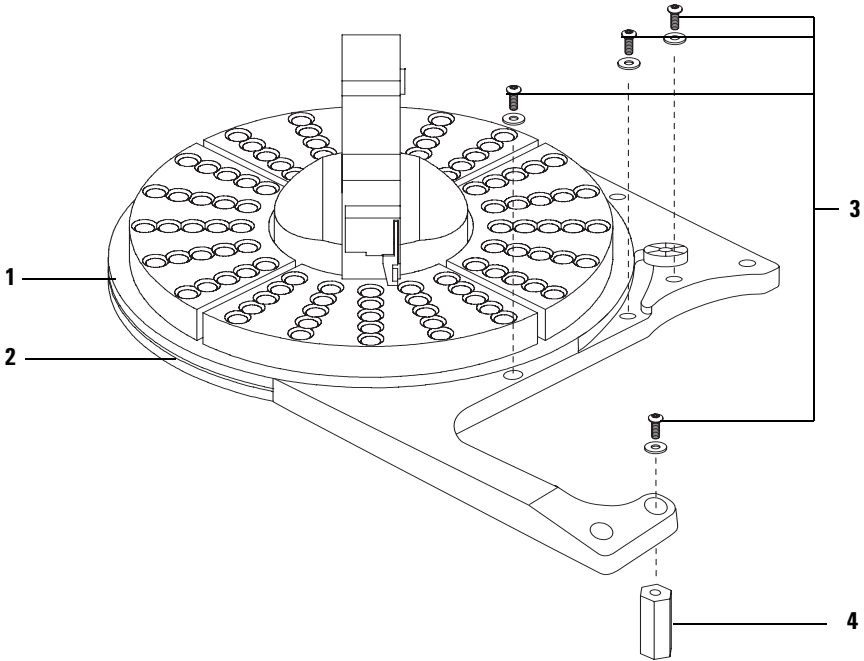

**Figure 79** G2916A tray replacement parts

### Miscellaneous Parts

**Table 35** Miscellaneous parts

<b>Item</b>	<b>Description</b>	<b>Part no.</b>	<b>Qty/Assy</b>
NS	5890 injector bracket screw kit	G2916-80520	1
NS	5890 to 6890 upgrade bracket screw kit	G2917-80530	1
NS	7683 injector bracket kit for 5890 GCs	G2916-61000	1
NS	PCA, ALS controller	G2912-65003	1



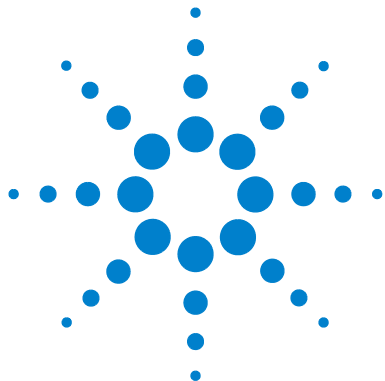

## A Cables and Connectors

G2916A/G2614A Trays [194](#)

G2612A — ALS Controller [197](#)

G2912-60507 — Remote Start/Stop Cable for 5890 Series II GCs [199](#)

G1530-60930 — Remote Start/Stop Cable for 6890A GC [200](#)

G1530-60600 — RS-232 Cable for 6890A or 5890 Series II GCs [201](#)

This appendix lists the external cables used for the 7683B sampler system, along with relevant pinouts for the connectors.



## G2916A/G2614A Trays

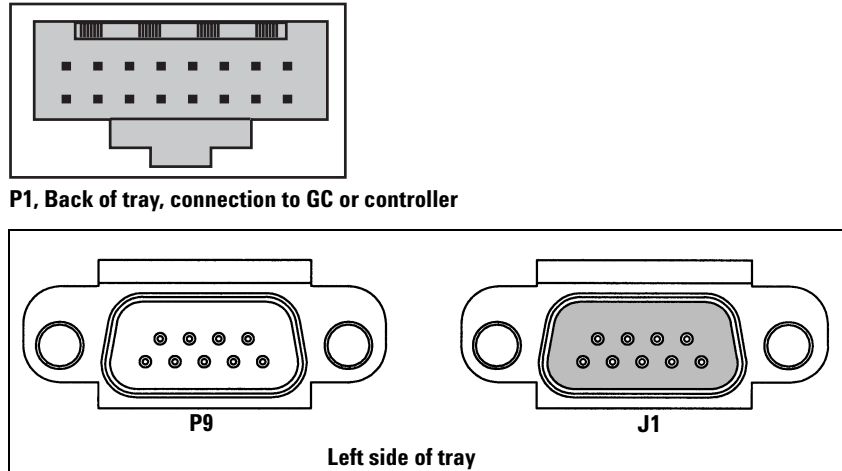

**Figure 80** Tray connectors

**Table 36** Tray connector P1, to GC or ALS controller

Pin	Signal
A1	TXD
A2	RTS
A3	DTR
A4	MRESET
A5	GND
A6	VAC1
A7	GND
A8	VAC2
B1	RXD

**Table 36** Tray connector P1, to GC or ALS controller (continued)

<b>Pin</b>	<b>Signal</b>
B2	CTS
B3	DSR
B4	GND
B5	GND
B6	VAC1
B7	GND
B8	VAC2

**Table 37** Tray connector P9, to Bar Code Reader (not used for G2916A on 5890 GC)

<b>Pin</b>	<b>Signal</b>
1	+5 VDC
2	NC
3	NC
4	RRD0 (motor)
5	RRD1 (motor)
6	RWAND
7	GND
8	+5V
PMH1	Chassis ground
PMH2	Chassis ground

**Table 38** Tray connector J1, auxiliary–reserved

<b>Pin</b>	<b>Signal</b>
1	CD
2	RXD
3	TXD
4	DTR
5	GND
6	DSR
7	RTS
8	CTS
9	RI
PMH1	GND
PMH2	GND

# G2612A — ALS Controller

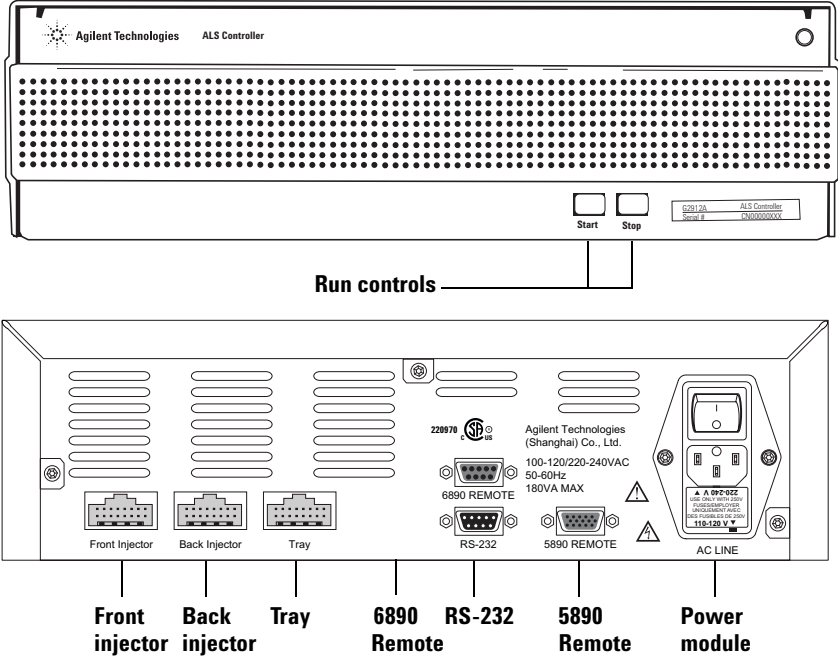

Figure 81 G2912A ALS controller

Table 39 6890 Remote connector

Pin #	Description
1	External ground
2	Not used
3	Start out, Low true
4-9	Not used

**Table 40** RS-232 connector  
9600 baud  
No hardware handshake

<b>Pin #</b>	<b>Description</b>
1	DCD-1, Data carrier detect
2	RX-1, Receive data
3	TX-1, Transmit data
4	DRT-1, Data terminal ready
5	Signal ground
6	DSR-1, Data set ready
7	RTS-1, Request to send
8	CTS-1, Clear to send
9	RI-1, Ring indicator

**Table 41** 5890 connector

<b>Pin #</b>	<b>Description</b>
1	Start out
2	Ready in
3	Start request in
4	Ready in
5	Not used
6	Start out
7	Jumpered to 11
8	Not used
9	Start request in
10	Not used
11	Jumpered to 7
12-15	Not used

## G2912-60507 — Remote Start/Stop Cable for 5890 Series II GCs

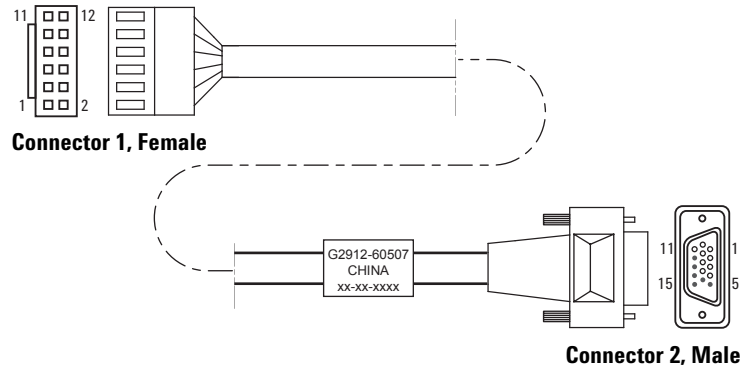
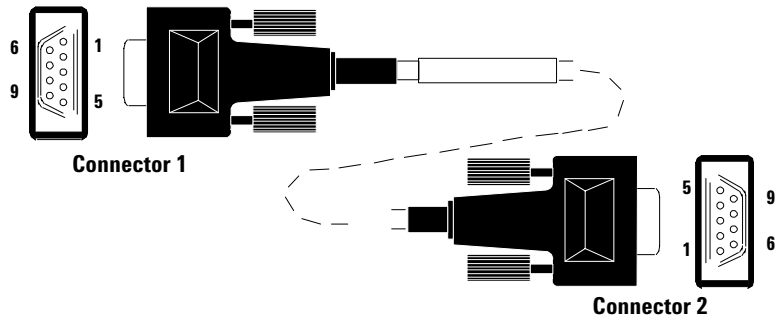

**Figure 82** G2912-60507 cable

**Table 42** G2912-60507 cable

Pin #	Connector 1	Connector 2	Description
1		10	
2		12	
3		4	Not defined
4		3	Start out
5		9	Not defined
6		8	Start out
7		2	Ready
8		5	
9		7	Configuration
10		11	Configuration
11		1	Start in
12		6	GND
		13	
		14	
		15	

## G1530-60930 — Remote Start/Stop Cable for 6890A GC



**Figure 83** G1530-60930 cable

**Table 43** G1530-60930 cable

Pin #	Description
1	Ground
2	Prepare
3	Start
4	Shut down (6890A/Plus), start relay (6890N)
5	Reserved
6	Power on (6890A/Plus), no connection (6890N)
7	Ready
8	Stop
9	Start request (6890A/Plus), no connection (6890N)



**G1530-60600 — RS-232 Cable for 6890A or 5890 Series II GCs**

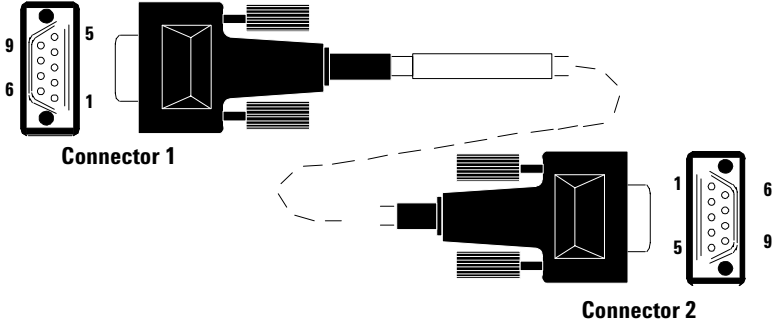

**Figure 84** G1530-60600 cable

**Table 44** G1530-60600 cable

Connector 1	Connector 2
1 - DCD	4 - DTR
6 - DSR	
2 - Rx	3 - Tx
3 - Tx	2 - Rx
4 - DTR	6 - DSR
	1 - DCD
5 - Ground	5 - Ground
7 - RTS	8 - CTS
8 - CTS	7 - RTS
9 - RI	

