ECE354 – Computer Systems Lab II

January 28th, 2004

UMassAmherst

Welcome!

- Course: “ECE 354 – Computer Systems Lab II”
- Classes:
 - Monday & Wednesday 2:30 – 5:30, Marston 132 & 228
 - Additional Lab times TBA
- Course homepage:
 - <http://www.ecs.umass.edu/ece/wolf/courses/ECE354/>
 - <https://webct.oit.umass.edu>
 - Most material online
- Instructor:
 - Tilman Wolf

Who is Tilman Wolf?

- Assistant Professor
 - Department of Electrical and Computer Engineering
- Education
 - D.Sc. in Computer Science (2002), M.S. in Computer Engineering (2000), M.S. in Computer Science (1998), Washington University in St. Louis
 - Diplom in Informatics (1998), Universität Stuttgart, Germany
- Previous courses
 - ECE 354 Spring 2003
 - Several computer networks courses (grad and undergrad)
- Research interests
 - Computer networks, network systems
 - Computer architecture
- Contact
 - Email: wolf@ecs.umass.edu
 - Come by: Knowles 211C

What is this Course About?

- ECE 354 is a course about:
 - Microcontrollers (simple, but versatile computers)
 - How to program them in assembly
 - How to build circuits around them (serial connection to terminal, memory interfaces, etc.)
 - Lab skills: designing, implementing, and debugging systems
 - Technical writing (lab reports)
- Hardware and software co-design
 - Similar to ECE 353
 - More software, less PLDs
- Preparation for Senior Design Project

What are Microcontrollers?

- **Microcontrollers:**
 - Self-contained computer-on-a-chip
 - CPU
 - non-volatile program memory
 - data memory
 - I/O capabilities
- **Application: Embedded Control**
 - Appliances
 - Automotive systems
 - Remote controls
 - Cordless phones
 - Etc.
- **Why are microcontrollers ideal for such devices?**

Microcontrollers

- Low cost
- Small packaging
- Low power consumption
- Programmable (Turing-complete)
- Re-programmable
- Lots of I/O capabilities
- Easy integration with custom circuits
- Software development and debugging tools

Microcontroller shipments
(billions of units)

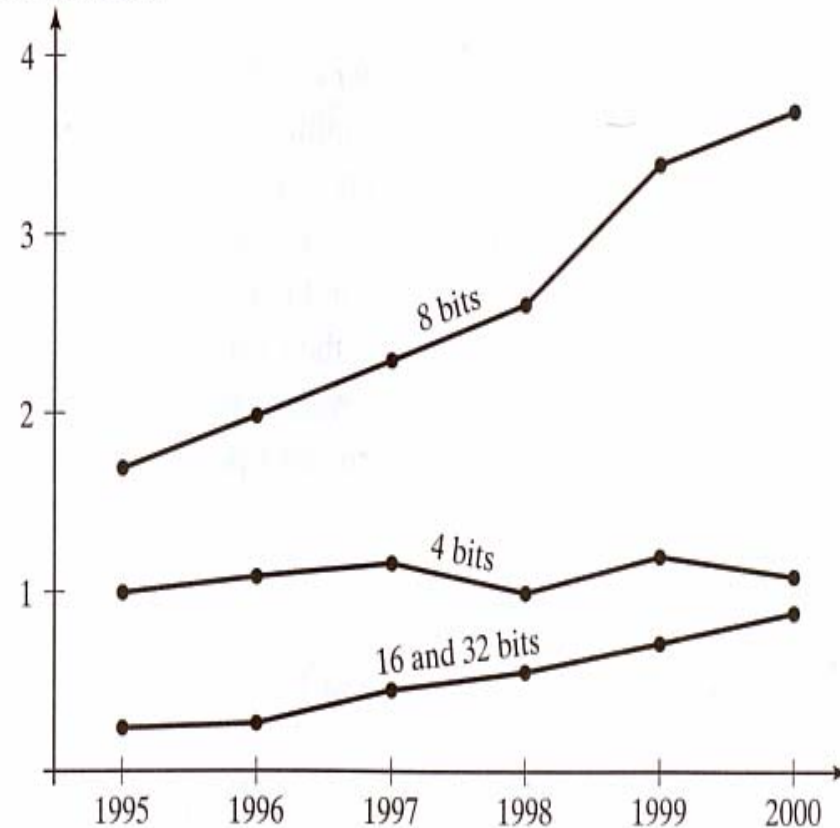

Characteristics

- Are they just like any other computer?
- Special features
 - A/D converter, timers, several I/O ports, serial port
- Harvard Architecture:
 - Separate program and data memory

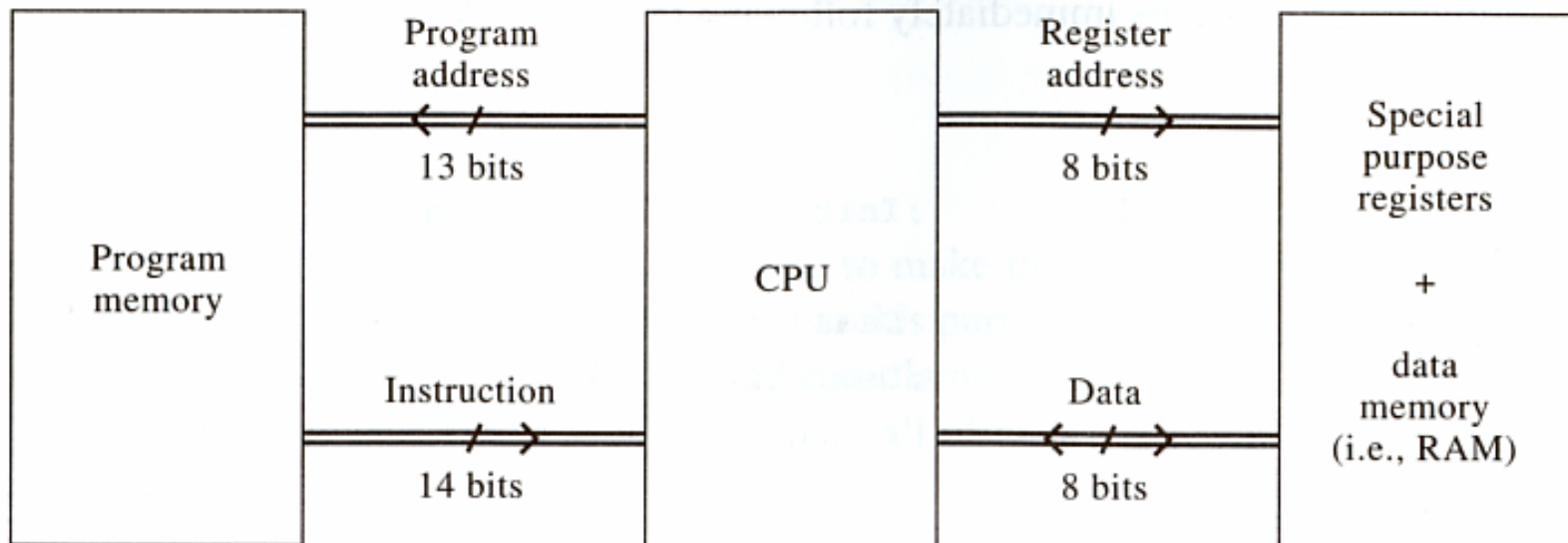

Why is this interesting?

- Many systems in computer engineering field use microcontrollers
- You learn to design system “from scratch”
- There are many different solutions and you can be creative
- Hardware and software combined in one system
- It’s very satisfying to get your system to run
- It’s a fun class – except the day before the lab is due 😊

Lab Equipment

- You will use:
 - PIC Microcontroller (MPLAB Kit)
 - Breadboard
 - Oscillators, Altera PLD, ...
- Computer connected to PIC
 - Download programs
 - Control execution
- Standalone mode possible
 - Put header on breadboard

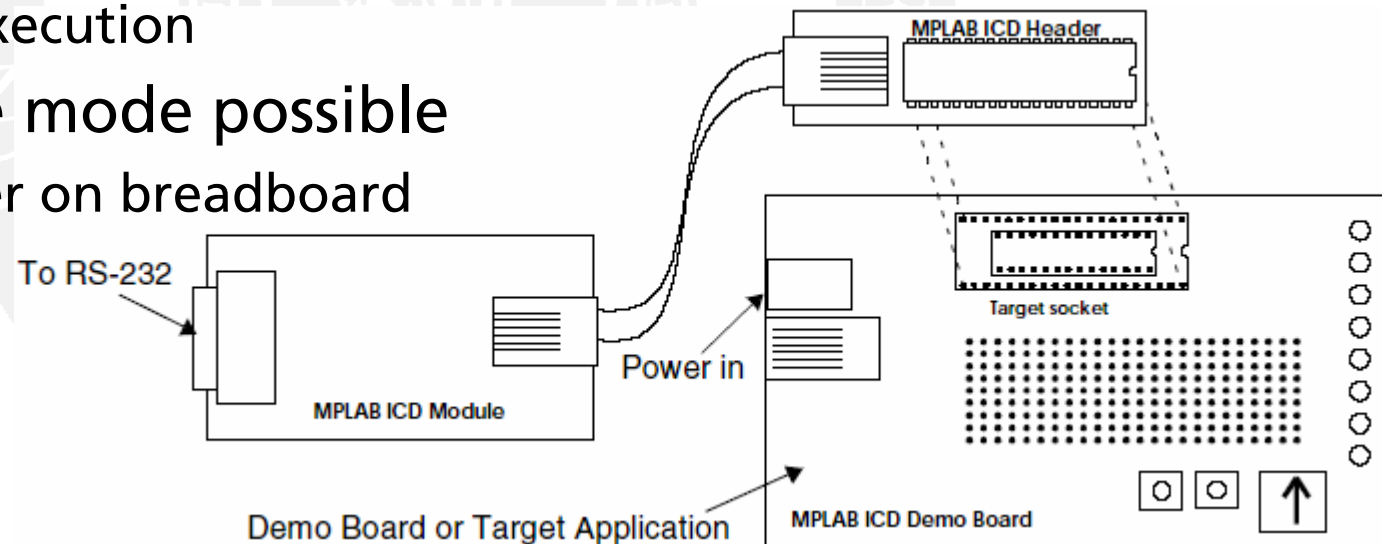

MPLAB IDE

- “Integrated Development Environment”
 - Editor to write code
 - Translates assembly to binary data that goes on PIC
 - Control panel to check status of PIC
 - Debugging features: breakpoints, stepping, memory inspection, etc.
- PIC needs to be programmed in assembly
 - Tutorial next Wednesday after introduction lecture to Lab 1

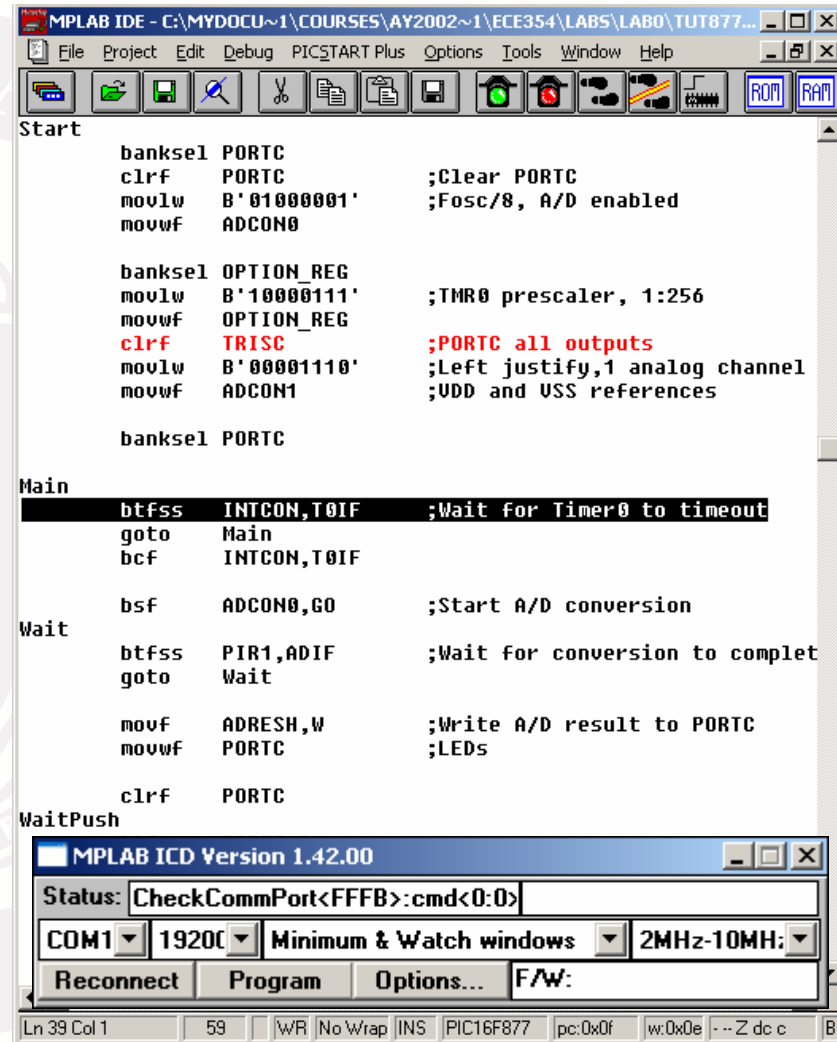

The screenshot displays the MPLAB IDE interface. The main window shows assembly code for a PIC16F877. The code is organized into sections: Start, Main, Wait, and WaitPush. The Start section initializes PORTC, sets the oscillator frequency to Fosc/8, and configures the TMR0 prescaler and TRISC register. The Main section contains a loop that waits for the TMR0 timeout, then starts an A/D conversion. The Wait section waits for the A/D conversion to complete and then writes the result to PORTC. The WaitPush section is currently empty.

```
Start
banksel PORTC
clrf PORTC           ;Clear PORTC
movlw B'01000001'   ;Fosc/8, A/D enabled
movwf ADCON0

banksel OPTION_REG
movlw B'10000111'   ;TMR0 prescaler, 1:256
movwf OPTION_REG
clrf TRISC          ;PORTC all outputs
movlw B'00001110'   ;Left justify, 1 analog channel
movwf ADCON1

banksel PORTC

Main
btfss INTCON,T0IF   ;Wait for Timer0 to timeout
goto Main
bcf INTCON,T0IF

Wait
bsf ADCON0,GO      ;Start A/D conversion

Wait
btfss PIR1,ADIF    ;Wait for conversion to complet
goto Wait

movf ADRESH,W      ;Write A/D result to PORTC
movwf PORTC        ;LEDs

clrf PORTC

WaitPush
```

Below the code editor, the MPLAB ICD Version 1.42.00 window is visible. It shows the status of the connection to the PIC16F877. The status is "CheckCommPort<FFFB>:cmd<0:0>". The COM1 port is set to 19200, and the baud rate is 2MHz-10MHz. The window also has buttons for "Reconnect", "Program", and "Options...".

Lab Topics

- Introduction Lab: Tools Tutorial
 - On class, not graded
- Lab 1: Serial Interface to Terminal
 - Connect PIC to RS-232 serial interface
 - Send and receive characters
- Lab 2: Bus Interface with PLD
 - Connect PIC to PLD and use as “co-processor”
- Lab 3: SRAM Memory Test System
 - Use PIC and PLD to read and write to memory chip
- Lab 4: Analog Communication
 - Use of A/D converter and PWM
- Lab 5: Compilation and DSPs
 - Software only
- Labs 1-3 are somewhat incremental, Labs 4 & 5 are independent

Lab Workflow

- Steps to complete a lab assignment:
 - Attend introduction lecture
 - Read assigned book chapters and data sheet pages
 - Start designing your solution
 - Complete quiz online*
 - Implement/debug your solution
 - Demo: brief individual quiz*, demonstration of implementation*
 - Write lab report*
- Important hint: start early!

* = graded

What will you learn?

- Technical content
 - PIC microcontrollers
 - Assembly programming
 - Designing circuit
- Practical skills
 - Implementing and debugging
- General skills
 - Plan projects and implement them on time
 - Communicate with team mate
 - Writing technical reports
 - Use web tools (online discussion, quizzes, etc.)
 - Oral check offs
- Balance of all skills is important

Grading

- 60% Lab grades (all labs count equal)
 - 30% individual pre-demo quiz (oral)
 - 30% Demo
 - 40% Lab report
- 30% Midterm
- 10% WebCT quizzes

WebCT

- Online components of ECE 354 are on WebCT:
 - <https://webct.oit.umass.edu>
 - Access with OIT login/password
- Important features
 - Quizzes
 - Discussion
 - Check your grades
- Quizzes
 - You can take it anytime within a few days
 - Yes, you could cheat, but you shouldn't – honesty policy applies
- Discussion
 - TAs and I will monitor discussions
 - Easiest way of sharing information with whole class
- Lectures and lab instructions remain on official course page:
 - <http://www.ecs.umass.edu/~wolf/ece/courses/ECE354>

WebCT

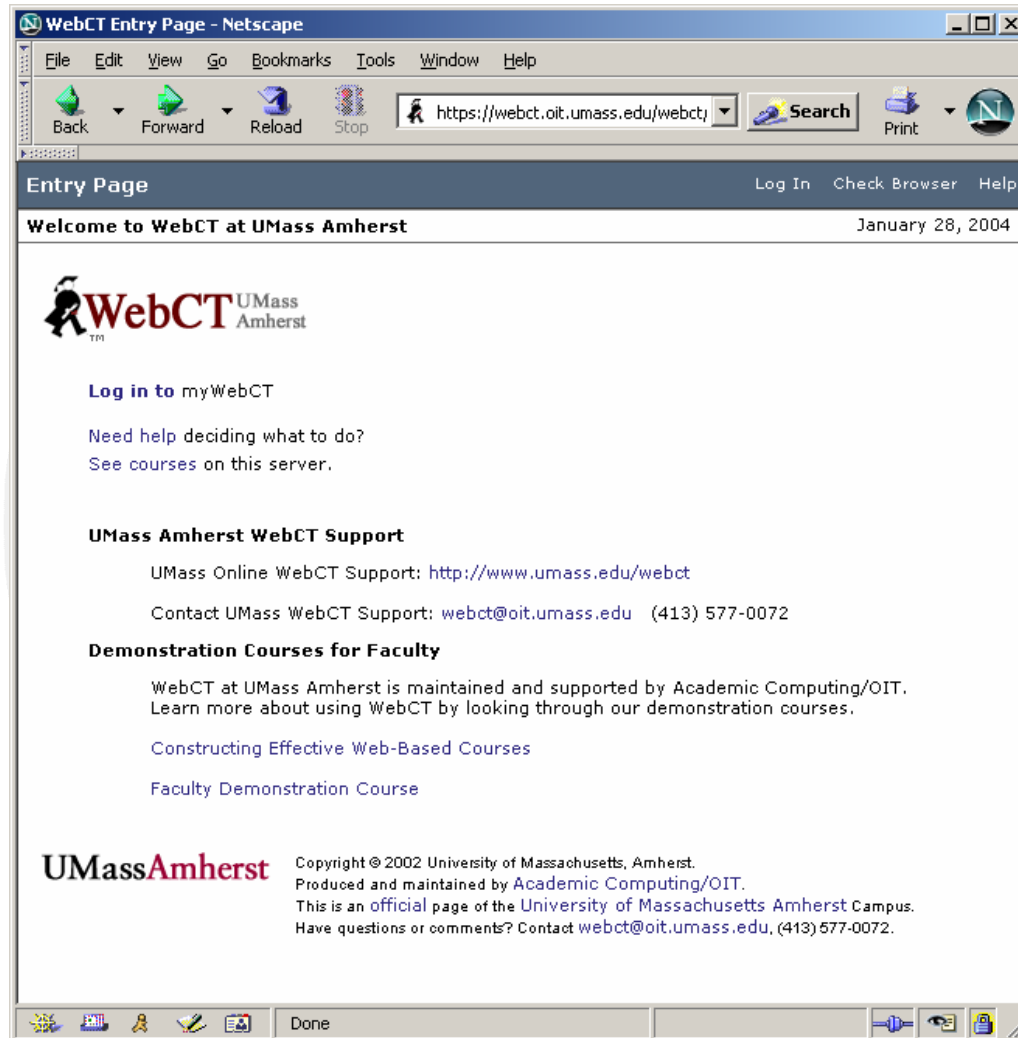

WebCT

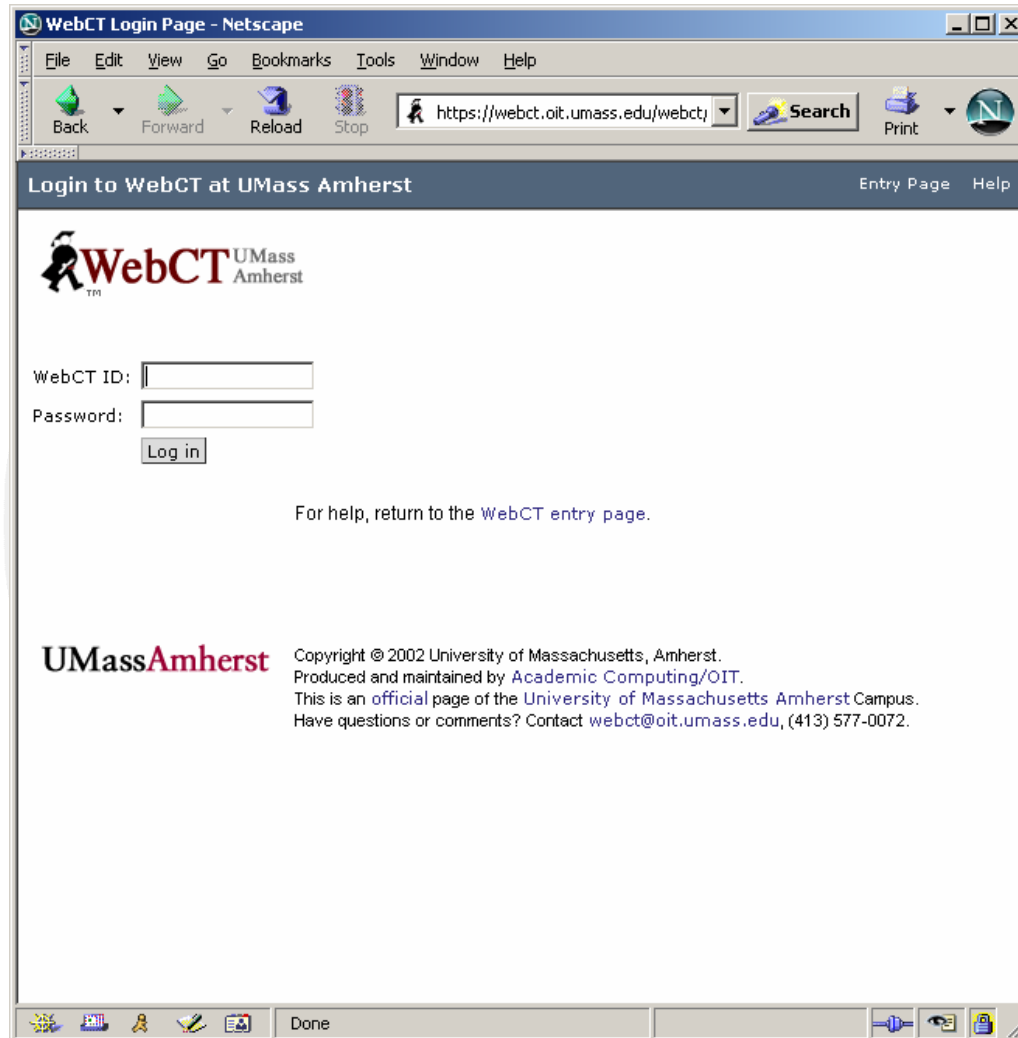

WebCT

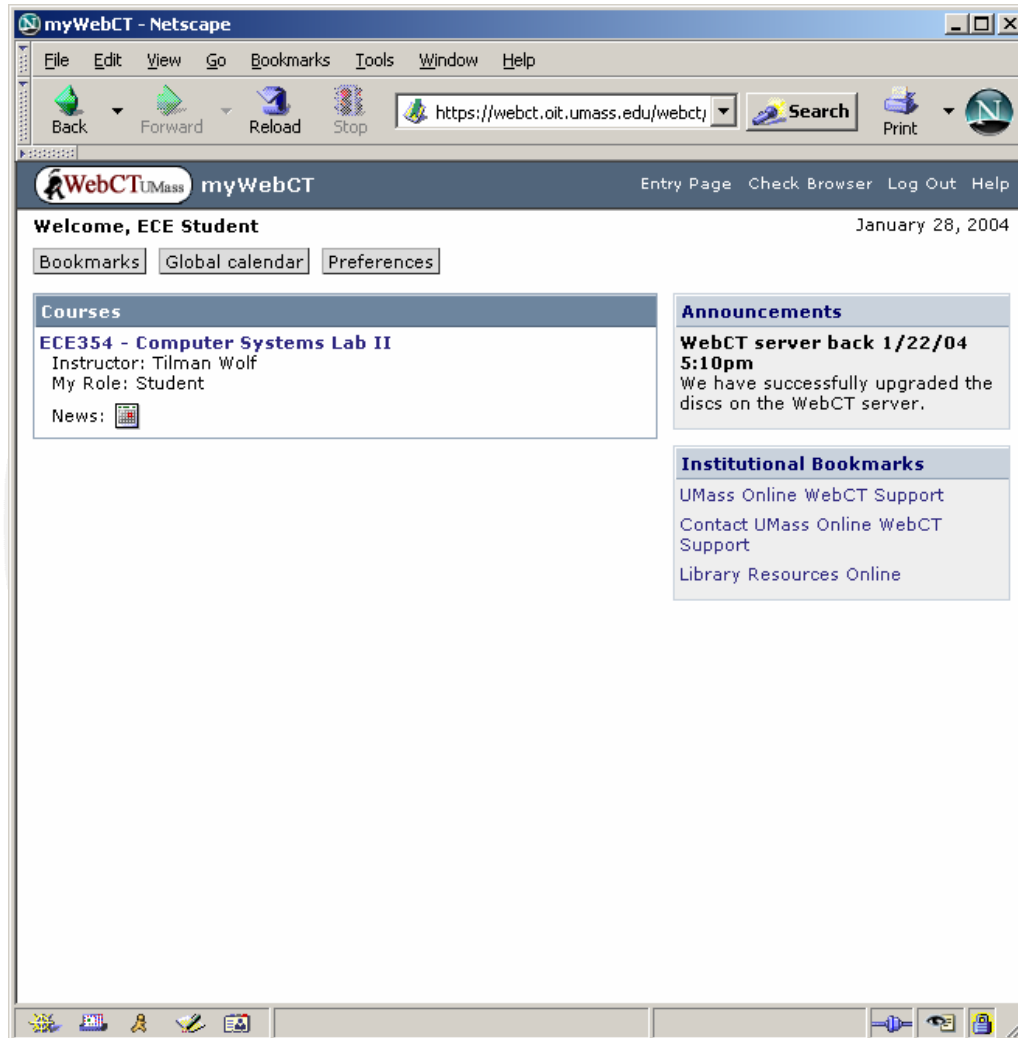

WebCT

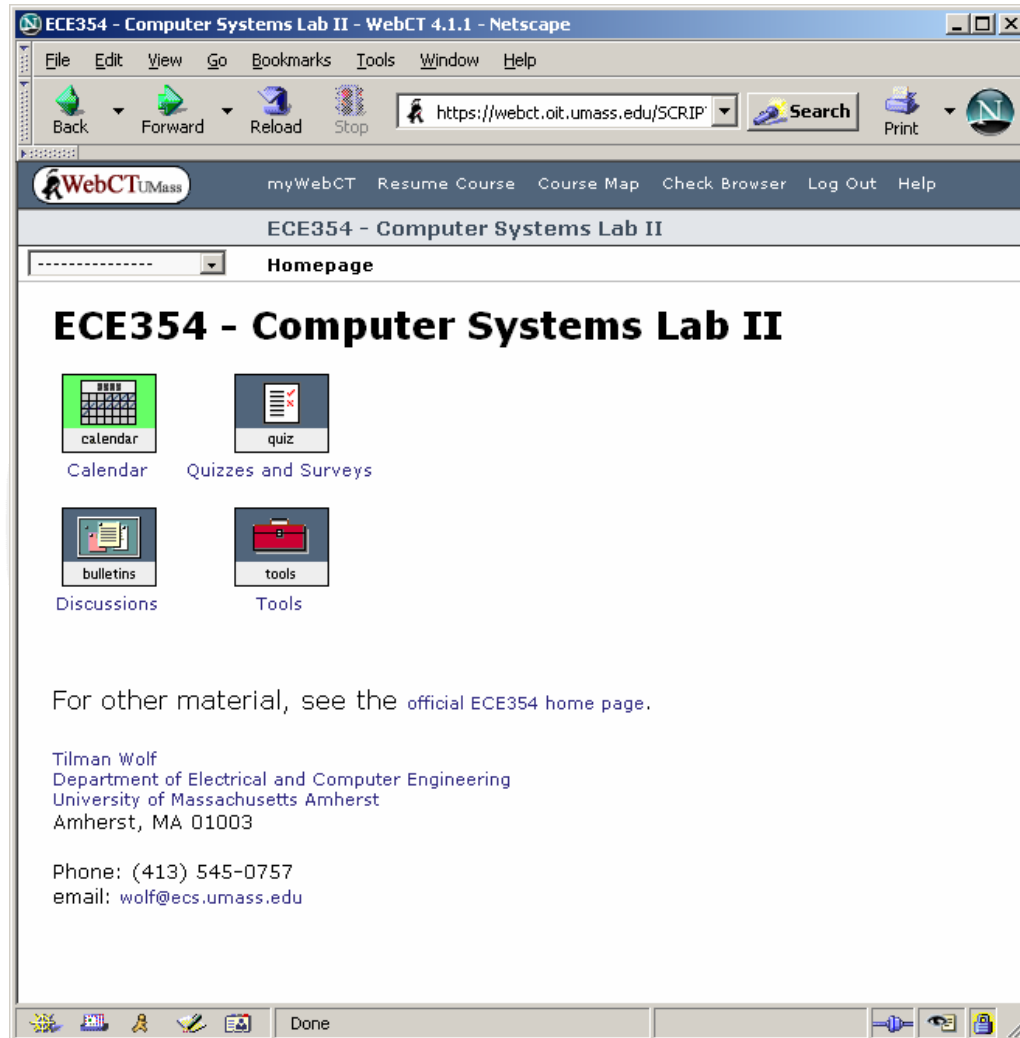

WebCT

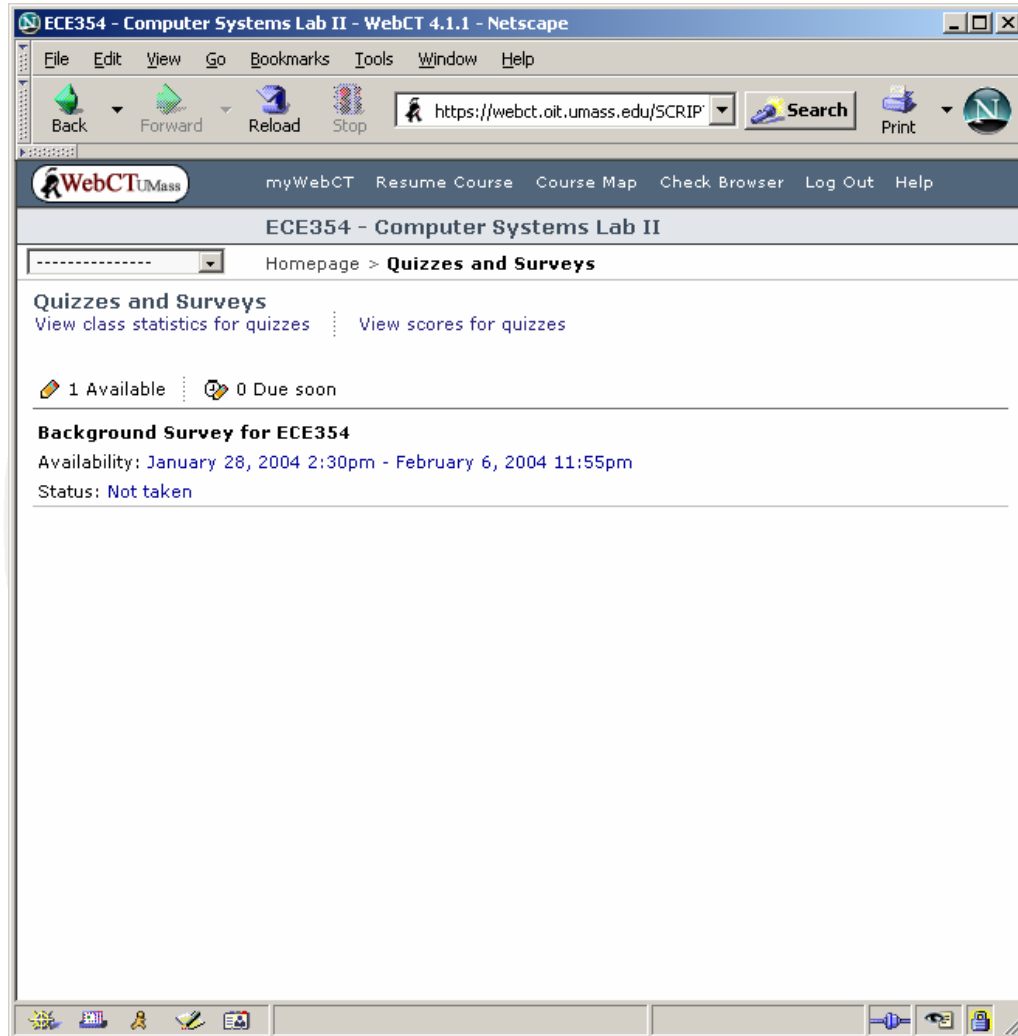

WebCT

The screenshot shows a Netscape browser window with the following elements:

- Browser Title Bar:** ECE354 - Computer Systems Lab II - WebCT 4.1.1 - Netscape
- Menu Bar:** File, Edit, View, Go, Bookmarks, Tools, Window, Help
- Navigation Buttons:** Back, Forward, Reload, Stop
- Address Bar:** https://webct.oit.umass.edu/SCRIP
- Search and Print Buttons:** Search, Print
- WebCT Header:** myWebCT, Resume Course, Course Map, Check Browser, Log Out, Help
- Page Title:** ECE354 - Computer Systems Lab II
- Navigation:** Homepage
- Discussions Section:**
 - Buttons: Compose message, Search, Topic settings
 - Text: Click on a topic name to see its messages.
 - Table of Topics:
- Status Bar:** Done

Topic	Unread	Total	Status
General Questions and Comments	0	0	public, unlocked
PIC Microcontroller Questions and Comments	0	0	public, unlocked
Assembly Programming Questions and Comments	0	0	public, unlocked
Introduction Lab	0	0	public, unlocked
Lab 1	0	0	public, unlocked
Lab 2	0	0	public, unlocked
Lab 3	0	0	public, unlocked
Lab 4	0	0	public, unlocked
Lab 5	0	0	public, unlocked
TEST TOPIC TO PRACTICE POSTING	0	0	public, unlocked
All	0	0	---

Team Signup

- Work is done in teams of two
 - Grading is individual
- We have 32 students
 - 16 teams
 - 13 workbenches
- There are two sections: A and B
 - Guaranteed work times for each section
 - Remaining time “free for all”
- Each team must sign up for one section
 - Signup sheet at my office door (Knowles 211C)
- Remember your team number (e.g., A5)
 - You’ll need it to sign up for demos

Lab Hours

- Lab is open
 - Mondays and Wednesday 2:30 – 5:30
 - Section A: 2:30 – 4:00
 - Section B: 4:00 – 5:30
- Additional lab times
 - Survey on WebCT lets you indicate when you have time
 - We'll try to accommodate everybody
 - Depends on availability of TAs
 - Possibly shared times with ECE 222
- Times will be announced next Monday & on web site

Lab Problems in ECE 353

- Notes from fixing logic analyzer lead sets:
 - Leads were braided (3x)
 - Lead 47 decapitated
 - Missing grey "8-15" patch
 - Lead 3 (red) obstructed by broken wire
 - Missing red Velcro "0-7" patch
 - Some lead tips (particularly grey 0-15) have teeth marks, presumably resulting from misuse of pliers
 - Missing grey Velcro "8-15" patch
 - Grey lead 9 (white) decapitated
 - Some leads extremely dirty, grease
 - Leads 19 & 39 obstructed by the same
 - Leads A3, B1, B2, & B13 decapitated
 - A GND lead is decapitated
- Lead sets cost up to \$500.
- Please be considerate with lab equipment!

Honesty Policy

- Consultation with fellow students is encouraged, especially on design issues. However, directly copying another student's work (past or present) defeats the purpose of the assignments and is an honor code violation. Lab reports, programs, or test answers that are directly copied from another student will result in serious penalties including course failure and possible action by the college disciplinary committee. If in doubt, please consult a TA, the instructor, or the official UMass guidelines regarding academic honesty.
- Special WebCT note: It is expected that students complete the online WebCT quizzes without help or discussion with other students. Do not post answers to quizzes in the online discussions.

Background Survey

- Need to know what you know
 - Trying to make sure you are not missing any background
- Need to determine when to open lab
 - Limited hours available for TA
 - Trying to maximize TA utilization
- Completely anonymous
- Good practice for using WebCT
 - Basically same interface as for quizzes

Homework

- Sign up with team partner
- Login to WebCT
- Fill out online survey
- Post one comment in the WebCT discussion
 - Use topic “TEST TOPIC TO PRACTICE POSTING ”
 - Post something interesting on microcontrollers
 - Or respond to a previous posting
- Read Peatman Chapter 1

Next Class

- In Lab: Marston 228
 - Section A: 2:30
 - Section B: 4:00
- Distribution of equipment
- Simple tutorial on how to use MPLAB Kit
 - MPLAB IDE User's Guide pp. 9–58