

# Viano



Chitula Chipimo  
CSE



Christopher Cunniff  
CSE

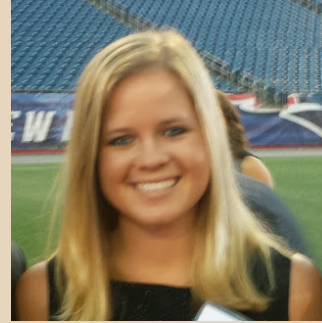

Kelly Kennedy  
EE



Anna Wildman  
EE

Advisor: Professor Anderson

# Agenda

- Review of Project
- CDR Deliverables
- Demo
- FDR Deliverables

# Pico-Projected Midi Controller

## Specifications:

- Portable (fit in small bag, lightweight)
- Dimensionally-correct keyboard
  - Immediate goal: 2-Octaves
- Seamless integration with GarageBand
- Not pressure sensitive\*\*

# Block Diagram

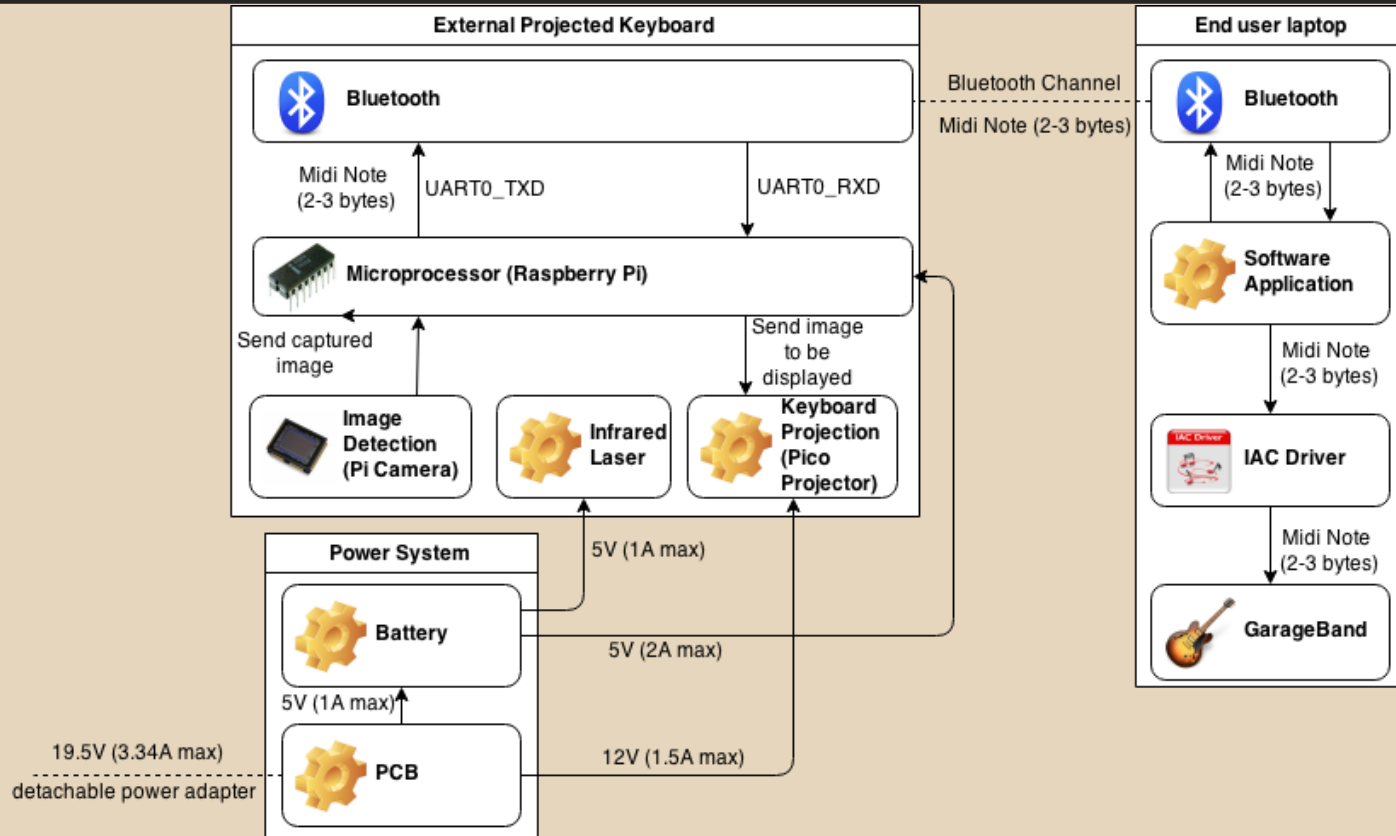

# Promised CDR Deliverables

Kelly

Design housing unit  
and wide-angle solution  
for projecting image

Anna

Design and Test a Power  
Circuit

Chi

Implement Virtual  
Coordinate Keyboard and  
Touch Calibration

Chris

Gui application on laptop  
and sending information  
from Raspberry Pi

# Viano Power Circuit: Description

## Design Challenges:

- Have 3 devices that need power
  - 2 - 5V (Raspberry Pi (5W), Linear Laser (25mW))
  - 1 - 12V (Pico Projector (18W))
- For portability, need batteries with a charging circuit
- Only want one charging cord for simplicity on user end

# Viano Power Circuit: Design Ideas

### Charging Circuit for Rechargeable Batteries

Item	Qty	Cost per Item	Cost per Order
Laptop Charger	1	0	0
UBEC 5V,3A	2	10	20
UBEC 12V, 3A	1	10	10
Rechargeable AA Batteries	18	2.75	49.5
PCB Charging Circuit	1	50	50
<b>Total</b>	<b>23</b>		<b>129.5</b>

### Manually Recharging/Replacing Batteries

Item	Qty	Cost per Item	Cost per Order
UBEC 5V, 3A	2	10	20
UBEC 12V, 3A	1	10	10
Rechargeable AA Batteries	18	2.75	49.5
Battery Recharger	5	16.99	84.95
<b>Total</b>	<b>26</b>		<b>164.45</b>

### Battery Pack

Item	Qty	Cost per Item	Cost per Order
Laptop Charger	1	0	0
USB Battery Pack	1	49.95	49.95
PCB Charging Circuit	1	50	50
<b>Total</b>	<b>3</b>		<b>99.95</b>

# Viano Charging & Power Circuit: Schematic

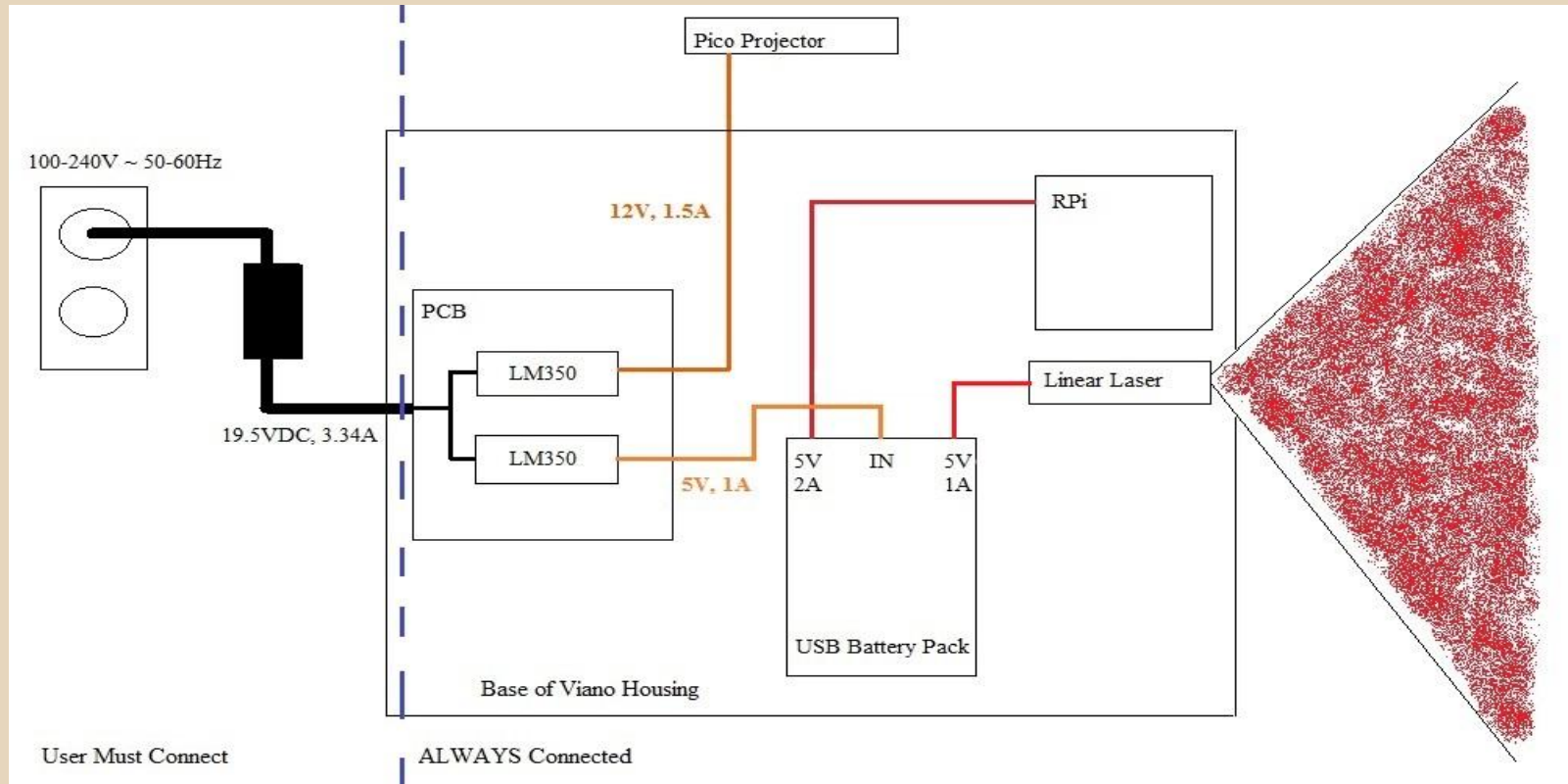



# Viano Charging Circuit: Testing

## FEATURES

- Specified 1% Output Voltage Tolerance (LM317A)
- Specified max. 0.01%/V Line Regulation (LM317A)
- Specified max. 0.3% Load Regulation (LM117)
- Specified 1.5A Output Current
- Adjustable Output Down to 1.2V
- Current Limit Constant with Temperature
- P\* Product Enhancement tested
- 80 dB Ripple Rejection
- Output is Short-Circuit Protected

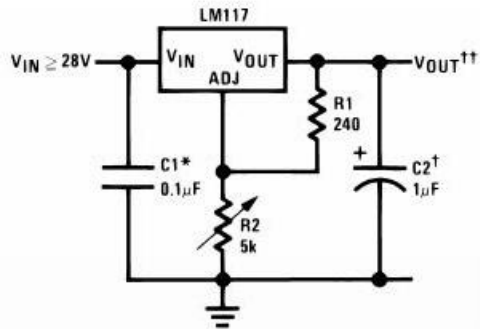

$R2_{\text{calculated}} = 2.06 \text{ (kohm)}$   
 $R2_{\text{measured}} = 2.02 \text{ (kohm)}$

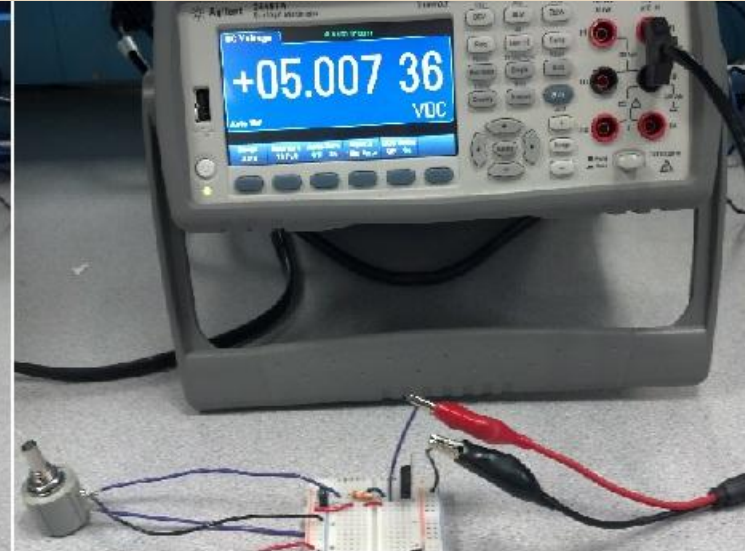

$R2_{\text{calculated}} = 720 \text{ (ohm)}$   
 $R2_{\text{measured}} = 707 \text{ (ohm)}$

# Projecting the Piano Image

## Design Challenges:

- Projecting bright enough image
- Keeping Viano overall size as compact as possible
- Finding a wide-angle solution that gave us the right magnification without distorting image
- Perspective Transformation Distortion

## Solution:

- New Pico Projector (DLP technology+100 lumens vs 6 lumens)
- High Definition .43x Wide Angle Lens
- Graphic Program for re-imaging

# Projecting Piano Image

New Projector + Wide-Angle Lens + Perspective Transformation



Before perspective transformation

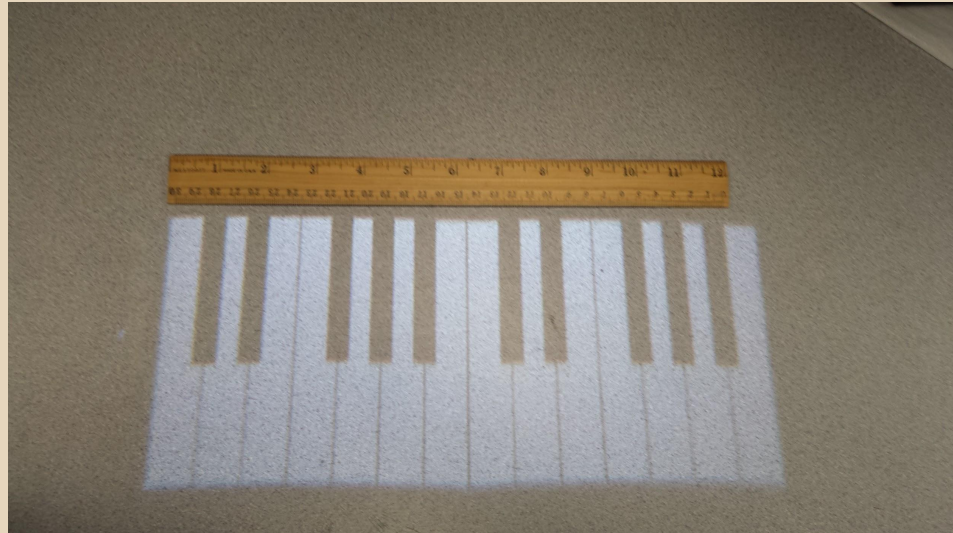

After perspective transformation

# Housing for the Viano

- Built via SolidWorks (CAD program)
- 6in x 6in x 12in
- Hollow, 4 individually piece design that will snap in with one another
  - allows for flexibility in design

(View in SolidWorks)

# Finger Tracking

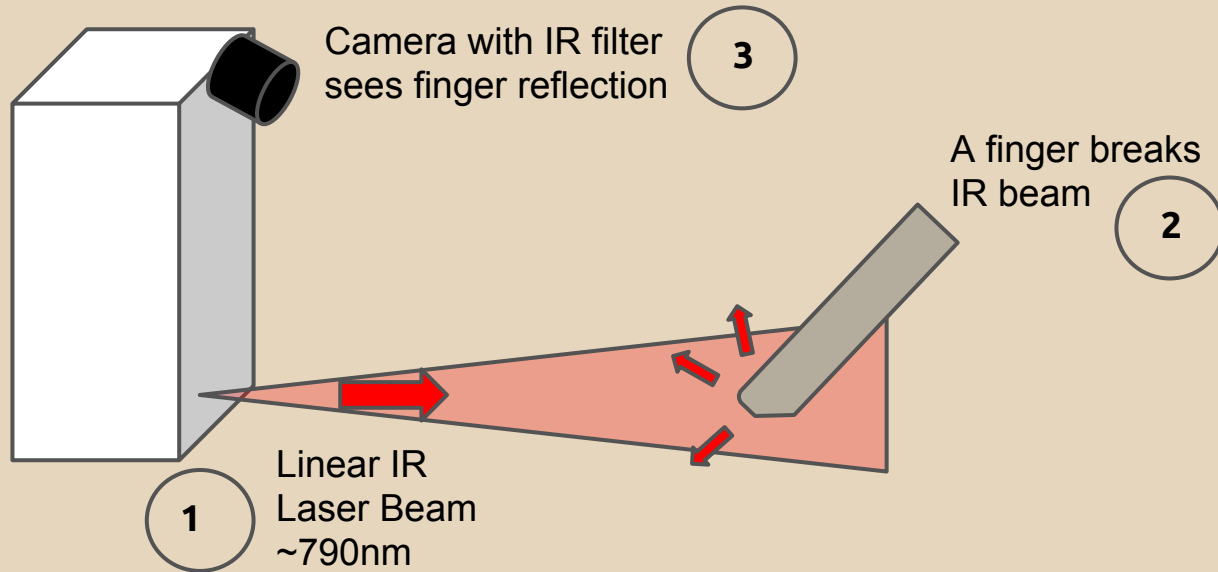

- Add keyboard and touch calibration

# Keyboard

- Defines a keyboard in 2D Euclidean space
- Input is finger coordinates
- Identifies key presses and releases
  - Uses a `KeyStateManager`, `KeyEventHandler`, and `MidiHandler` to receive, interpret, and pass on data
- Output is MIDI messages
- Contains a simulator for visual testing

# Touch Calibration

## Camera & projector placement:

- Either rigid
  - Once-off coordinate mappings
  - Errors introduced by camera or projector moving
  - ~~Hard-code (this may be tedious to update)~~
- Or flexible
  - Parts may move/tilt/vary
  - Arbitrary placement of camera and projector
  - User calibration at startup

# Bluetooth Communication

- Transmission (Raspberry Pi)
  - Slave bluetooth adapter via UART on Pi's GPIO
  - Code to transmit MIDI notes over channel
  - Current transfer rate approx. 300 notes/s
- Receiving (Desktop)
  - Java App to receive/process transmitted data
  - Play notes on garageband
  - Allows for user definition of note velocity



# Demonstration

CDR Deliverable	Who is Responsible?	Has it Been Achieved?	What is Left?
Design Housing Unit	Kelly	Yes - Overall Design	Final Dimensions and 3D Printing
Find Wide-Angle Solution for Projecting Image	Kelly	Yes - Accurate Width/Length of 2 Octaves	Sync Key Width with Software
Design and Test a Power Circuit	Anna	Yes - USB Battery Pack	Charging PCB
Implement Keyboard and KeyEventProcessor classes	Chi	Yes	Adjust Individual Key Dimensions
Implement Touch Calibration at Startup	Chi	Yes	Improve Separation of Fingers
Gui Application on Laptop	Chris	Yes	Improve UI
Sending Information from Raspberry Pi	Chris	Yes	Nothing

# Final Design Review Deliverables

## **Kelly**

Have Housing printed and implemented for Viano.  
Correct dimensions of piano keyboard that will sync with the software

## **Anna**

Design and Order a Charging PCB using Cadsoft Eagle Software

## **Chi**

Add control keys to keyboard for changing instrument.  
Discuss efficient image-processing improvements with Prof. Erik Learned-Miller.

## **Chris**

Integrate pthreads into code base to utilize quad core on Raspberry Pi 2.  
To maintain frame rate when increase image resolution.