

1D UltraSonic Anemometer

Preliminary Design Review

by

Vanessa Dubé

Michael Jao

Chethan Srinivasa

Robert Vice

Background

- What is a Sonic Anemometer?
 - Device that measures wind speed
- What will be our tasks?
 - Measure small wind speed
 - Generate our own frequency
 - Make it inexpensive and as light as possible

Block Diagram

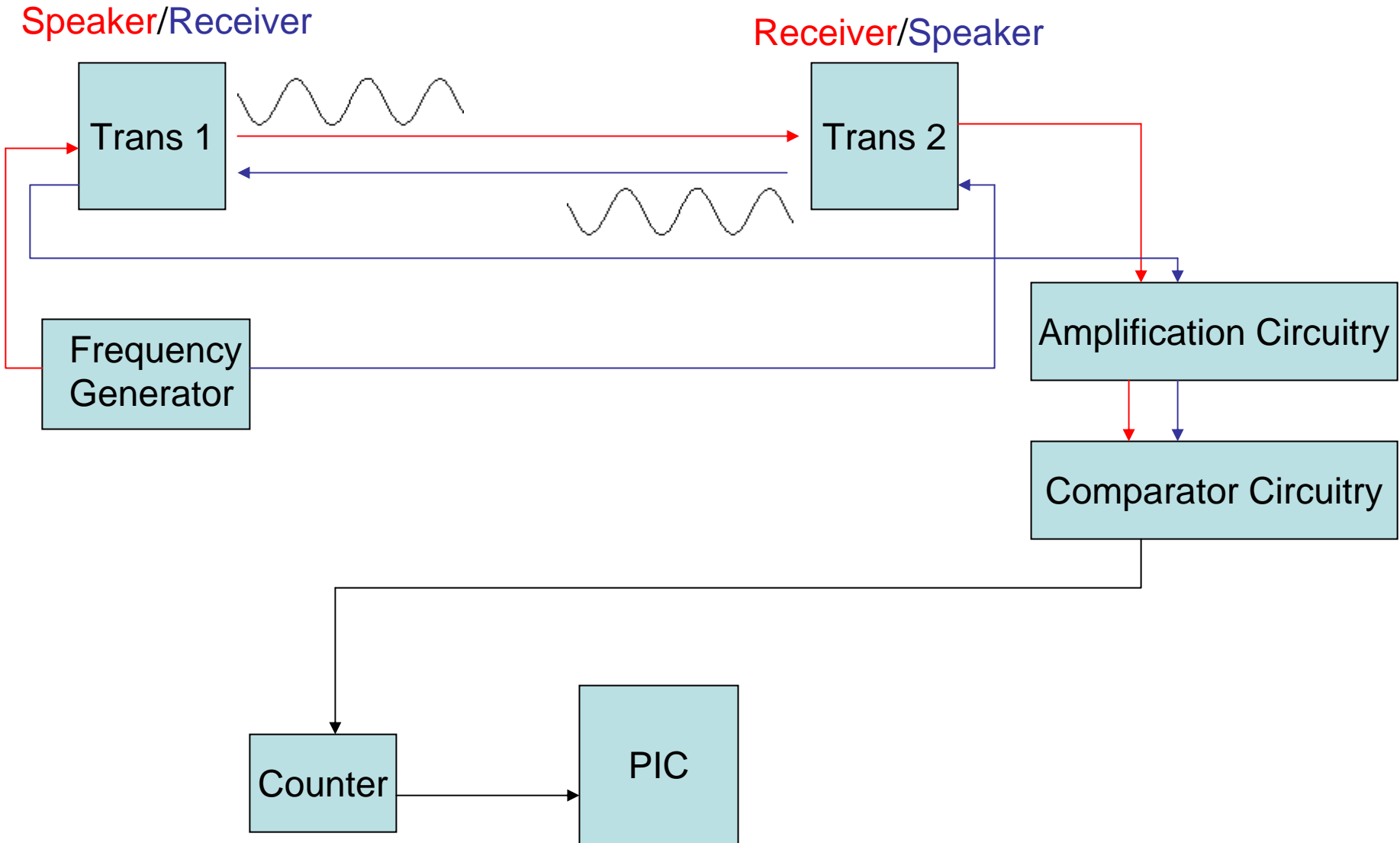

Possible Errors

- Transducer angular offset
 - Negligible because change in angular offset has relative effect
- Chip Delay
 - Average of several hundred measurements taken every second

Preliminary Design

- Familiarize then Test and Implement
Send/Receive transducers, minimizing noise
- Experiment with air flow generators to simulate wind
- Implement counters along with other circuitry to calculate time delay of sine waves
- Use simple methods to calculate wind speed, thus verifying our experimental anemometer

Initial Calculations

- Assume: $v_{\text{wind}} = 1 \text{ mm/s}$, $d = 1 \text{ m}$

Calculate Δt and then take the inverse to find the desired counter frequency

$$V_1 - V_2 = (.001) * 2 \text{ [m/s]}$$

Now, calculate t_1 and t_2 :

$$t_1 = 3.030303 \text{ [ms]}$$

$$t_2 = 3.030284665 \text{ [ms]}$$

Initial Calculations (cont'd)

$$\Delta t = t_1 - t_2 = 1.8365e-8 \text{ [s]}$$

So, frequency is $1/\Delta t$: 54.45 MHz

Frequency = 54.45 MHz \longrightarrow 26 bit register

Proposed MDR Prototype Specifications

- Create an experimental anemometer that can measure small wind speeds
- Send and Receive ultrasonic signals across transducers, that are not affected by noise
- Multiply our two sent signals to generate a pulse whose width determines the phase offset, thus allowing us to calculate windspeed
- Minimize power, weight, and cost