

Espresso illustrated

Single output functions

- Expand input part: $(0\ 0\ 0\ | 1) \Rightarrow (0\ -\ 0\ | 1)$
- Reduce output part: $(0\ 1\ -\ | 1) \Rightarrow (0\ 1\ -\ | 0)$
(remove the cube)

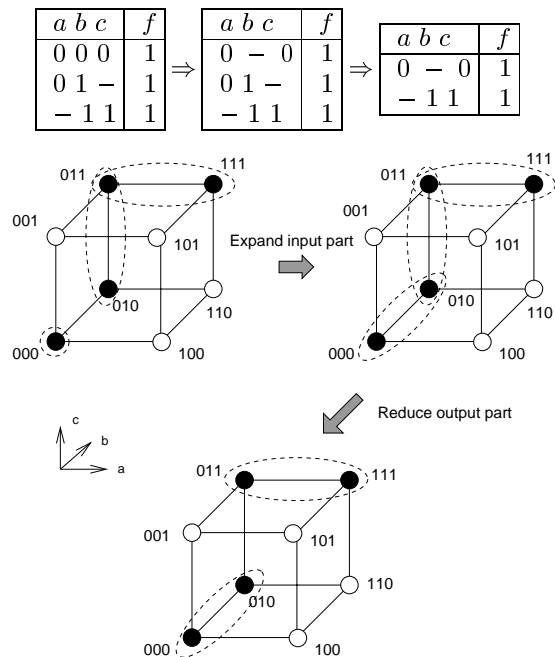

How to Expand & Reduce

Two problems:

- Choice of the cube to be expanded or reduced, and the direction.
- Validity of expansion (reduction).

Containment check: check if the cube being expanded (reduced) is contained in F .

- * Let c be the cube being expanded (reduced), and \tilde{c} be the cube that contains the added/removed minterms. Need to check if: $\tilde{c} \subseteq (F - c)$.

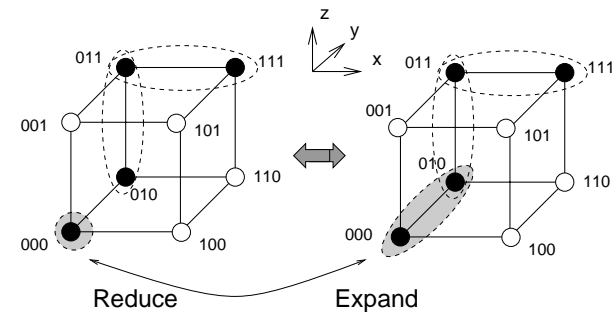

This can be solved by the tautology check:

$$(F - c)_{\tilde{c}} \equiv 1$$

Expand

Multiple-output functions

- Expand output part:
 $(0 - 1 \mid 1 0) \Rightarrow (0 - 1 \mid 1 1)$

$a b c$	$f_1 f_2$	$a b c$	$f_1 f_2$
0 - 1	1 0	0 - 1	1 1
1 - 0	1 0	1 - 0	1 0
0 0 -	0 1	0 0 -	0 1
- 0 0	0 1	- 0 0	0 1
- 1 1	0 1	- 1 1	0 1

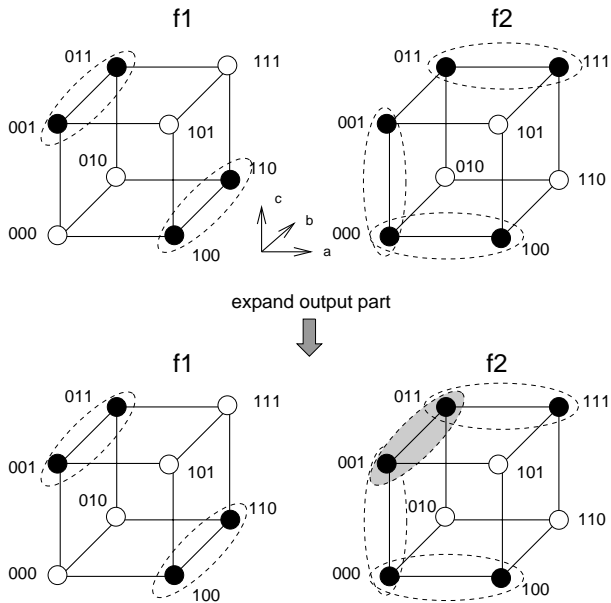

Remove redundancy

- Remove redundant cube $(0 0 - \mid 0 1)$

$a b c$	$f_1 f_2$	$a b c$	$f_1 f_2$
0 - 1	1 1	0 - 1	1 1
1 - 0	1 0	1 - 0	1 0
0 0 -	0 1	1 - 0	1 0
- 0 0	0 1	- 0 0	0 1
- 1 1	0 1	- 1 1	0 1

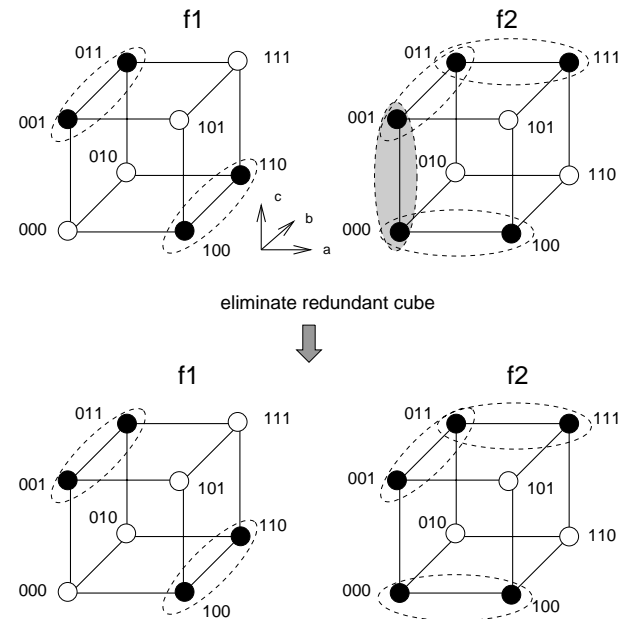

Expand-reduce summary

Multiple-output functions

<i>a b c</i>	<i>f₁f₂</i>
0 - 1	1 0
1 - 0	1 0
0 0 -	0 1
- 0 0	0 1
- 1 1	0 1

 \Rightarrow

<i>a b c</i>	<i>f₁f₂</i>
0 - 1	1 1
1 - 0	1 0
0 0 -	0 1
- 0 0	0 1
- 1 1	0 1

 \Rightarrow

<i>a b c</i>	<i>f₁f₂</i>
0 - 1	1 1
1 - 0	1 0
- 0 0	0 1
- 1 1	0 1

