

UMass Amherst
Adaptive Use Bridge Project
Golden Hill Road Bridge Tension Test Methods

The tension coupons used in testing were cut from pieces of wrought iron bridge members. One beam hanger from the Golden Hill Road Bridge was used to make four tension coupons. Tension testing was performed in accordance to ASTM E8-04. The wrought iron material was machined into round coupons with a gauge diameter of 0.5 inches. The dimensions of the tension coupons can be seen in Figure 1. The coupons were held in the tension machine by custom made shoulder grips. Figure 2 features a photograph of the tension grips.

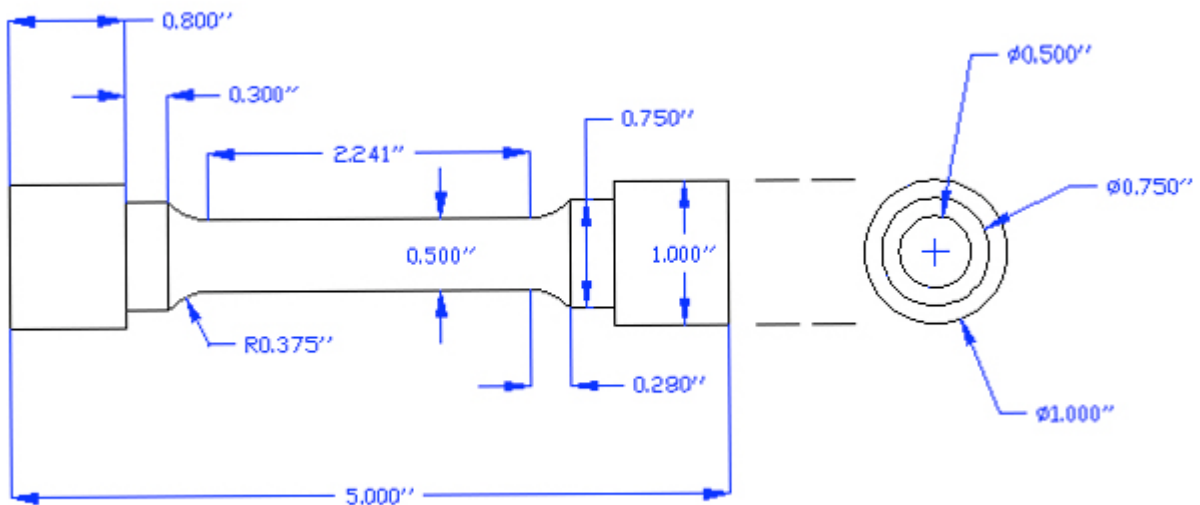

Figure 1. Tension coupon dimensions.



Figure 2. Custom made shoulder grips used to hold the tension coupons during testing.

While testing, the specimens were subject to 0.005 inches of strain per minute until 20 ksi of stress was reached. During this time, an extensometer was used to accurately measure strain. After 20 ksi of stress was reached, the extensometer was removed and the strain rate was increased to 0.05 inches per minute. The testing machine's cross head displacements were used to record strain measurements after the extensometer was removed. Testing continued until the specimen failed.

The extensometer is an accurate yet fragile measurement tool. To avoid damaging this piece of equipment it was removed while each test was still in progress. It was found that the cross head displacement measurements made by the testing machine were precise however inaccurate. A method to correct the results and remove this inaccuracy was developed and applied to all of the raw data. The stress-strain elastic range's linear behavior was used to correct misleading data. Figure 3 includes uncorrected and corrected stress strain plots for a tension sample.

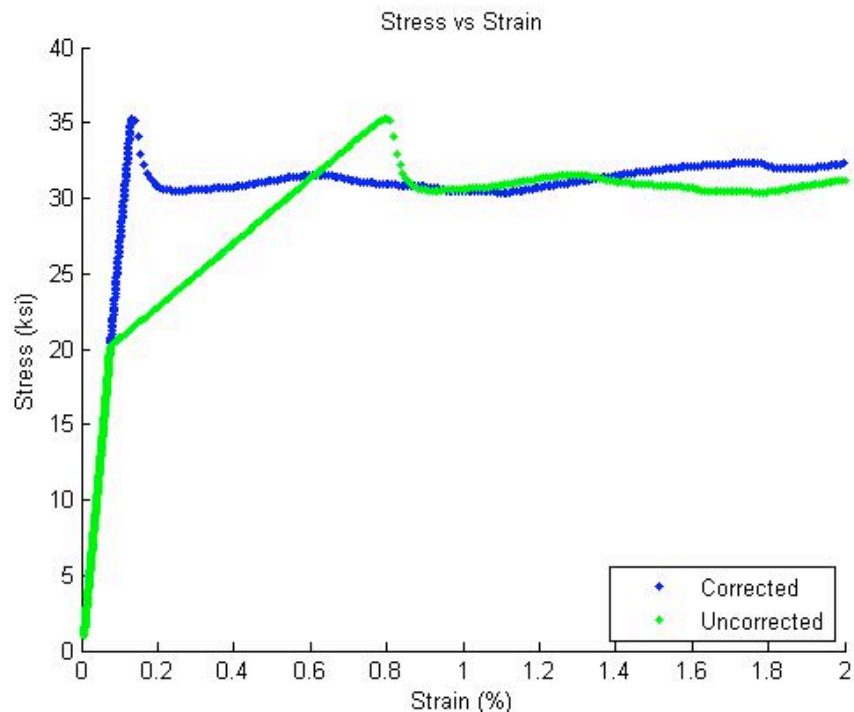

Figure 3. Uncorrected and corrected stress strain diagrams.

The tension test results provide valuable information on the material at hand. The modulus of elasticity, yield strength, tensile strength and percent elongation at failure can all be obtained from tension testing. These material properties are used when planning reconstruction of historic bridges.